

**SPECIAL, 2/15/2022 10:30:00 AM**

BE IT REMEMBERED that on February 15, 2022, there was begun and holden a SPECIAL session of the Commissioners Court of Jefferson County, Texas, with the following members and officers present and participating except those absent as indicated:

Honorable Jeff Branick, County Judge

Commissioner Vernon Pierce, Commissioner Pct. No. 1

Commissioner Darrell Bush, Commissioner Pct. No. 2

Commissioner Michael Sinegal, Commissioner Pct. No. 3

Commissioner Everette D. Alfred, Commissioner Pct. No. 4

Honorable Zena Stephens, Sheriff (ABSENT)

Chief Donta Miller

Honorable Laurie Leister, County Clerk

When the following proceedings were had and orders made, to-wit:

*Notice of Meeting and Agenda and Minutes*  
*February 15, 2022*

Jeff R. Branick, County Judge  
 Vernon Pierce, Commissioner, Precinct One  
 Darrell Bush, Commissioner, Precinct Two  
 Michael S. Sinegal, Commissioner, Precinct Three  
 Everette "Bo" Alfred, Commissioner, Precinct Four



**NOTICE OF MEETING AND AGENDA  
 OF COMMISSIONERS' COURT  
 OF JEFFERSON COUNTY, TEXAS  
 February 15, 2022**

Notice is hereby given that the Commissioners' Court of Jefferson County, Texas, will meet at **10:30 AM**, on the **15th** day of **February 2022** at its regular meeting place in the Commissioners' Courtroom, 4th Floor, Jefferson County Courthouse, 1149 Pearl Street, Beaumont, Texas.

Said meeting will be a **Special** for the purpose of transacting the routine business of the County. Persons with disabilities requiring auxiliary aids for services who wish to attend this meeting should contact the County Judge's Office to arrange for assistance.

In addition to the routine business of the County, the subject of said meeting will be the following:

9:00 a.m. - Announcement of an executive (closed) session pursuant to Texas Government Code Section 551.074 to deliberate regarding personnel matters.

9:30 a.m. Workshop-Receive update on Emergency Rental Assistance Program.

Jefferson County has taken steps to minimize the exposure of COVID-19 by implementing the following steps to allow the public to view the Commissioner's Court meeting.

The following options are available:

View live with audio from the County Webpage: [https://co.jefferson.tx.us/comm\\_crt/commlink.htm](https://co.jefferson.tx.us/comm_crt/commlink.htm)

Listen to audio by calling 346-248-7799 Meeting ID: 917 160 6532# Participant ID: # The court will also have a question and answer session at the end of the meeting. If you would like to ask any questions of the Court, please be on the phone call. The Court will give a question and answer session at the end of the meeting as time allows. You will be called upon by your last 4 digits of your phone number. If you do not have any questions, you can pass.

Please be mindful that the audio portion of this meeting will be of better quality from the website.

*Notice of Meeting and Agenda and Minutes*  
*February 15, 2022*

**INVOCATION: Michael S. Sinegal, Commissioner, Precinct Three**

**PLEDGE OF ALLEGIANCE: Everette "Bo" Alfred, Commissioner,  
Precinct Four**

## **PURCHASING:**

1. Receive and file Change Order No. 3 for (IFB 21-004/JW) Phase VI: First-Time Sanitary Sewer Improvements Project for Jefferson County (Community Development Block Grant) with Jet Aeration of Texas, LLC. for an increase of \$9,251.00 for the addition of electrical subpanels required for two of the proposed installations and one additional grinder station installation; bringing the total contract from \$136,034.25 up to \$145,285.25. This project is funded by a Texas Community Development Block Grant from The Texas Department of Agriculture. (TxCDBG Contract No. 7218240); pursuant to Chapter 262, Texas Local Government Code, the County Purchasing Act and 2 CFR Sections 200.318 – 326.

**SEE ATTACHMENTS ON PAGES 12 - 15**

**Motion by: Commissioner Pierce**

**Second by: Commissioner Bush**

**In favor: County Judge Branick, Commissioner Pierce, Commissioner Bush, Commissioner Sinegal, Commissioner Alfred**

**Action: APPROVED**

2. Consider and approve purchase for Courthouse Cabling project to Maverick Communications in the amount of \$ 218,653.71. This in accordance with Region V Telecommunications Equipment, Supplies and/or Services Contract 20210204.

**SEE ATTACHMENTS ON PAGES 16 - 16**

**Motion by: Commissioner Pierce**

**Second by: Commissioner Bush**

**In favor: County Judge Branick, Commissioner Pierce, Commissioner Bush, Commissioner Sinegal, Commissioner Alfred**

**Action: APPROVED**

3. Consider and approve CS1000 Phone System Upgrade to Enterprise Systems Corporation in the amount of \$ 518,024.19. This is in accordance with TIPS Interlocal Purchasing System Networking Equipment, Software, and Services Contract 21050301.

**SEE ATTACHMENTS ON PAGES 17 - 17**

**Motion by: Commissioner Pierce**

**Second by: Commissioner Bush**

**In favor: County Judge Branick, Commissioner Pierce, Commissioner Bush, Commissioner Sinegal, Commissioner Alfred**

**Action: APPROVED**

*Notice of Meeting and Agenda and Minutes  
February 15, 2022*

4. Consider and approve, execute, receive and file (Agreement 22-010/JW) with Thomson Reuters (Westlaw) for an online access subscription for County Court at Law No. 1. This single-user agreement is for a one-year term at a monthly cost of \$57.00 until the next DIR contract year begins on September 1, 2022, at which the cost will increase to \$60.00 per month, as shown on ATTACHMENT A. (DIR Contract Option 1-A, Option Years 5 and 6)

**SEE ATTACHMENTS ON PAGES 18 - 34, Page 32A was omitted and is Page 144**

**Motion by: Commissioner Pierce**

**Second by: Commissioner Bush**

**In favor: County Judge Branick, Commissioner Pierce, Commissioner Bush, Commissioner Sinegal, Commissioner Alfred**

**Action: APPROVED**

5. Consider and approve, execute, receive and file Task Order #2 for (RFP 21-024/YS), FEMA Grant Management and Insurance Advisory Services for Jefferson County with Tidal Basin Government Consulting, LLC to provide grant management to apply for HMGP -COVID funds and application development assistance for future home elevations and to assist in gaining full approval for your FMA FY2020 elevation project for an amount not to exceed \$20,045.00; pursuant to Chapter 262, Texas Local Government Code, the County Purchasing Act and 2 CFR Section 200.318-326.

**SEE ATTACHMENTS ON PAGES 35 - 36**

**Motion by: Commissioner Pierce**

**Second by: Commissioner Bush**

**In favor: County Judge Branick, Commissioner Pierce, Commissioner Bush, Commissioner Sinegal, Commissioner Alfred**

**Action: APPROVED**

6. Consider and approve an auction of surplus property as authorized by Local Government Code §263.152 (a) (1) by Horn's Auction, Inc. The auction is scheduled for Saturday, March 5, 2022 at 9:00 a.m.

**SEE ATTACHMENTS ON PAGES 37 - 41**

**Motion by: Commissioner Pierce**

**Second by: Commissioner Bush**

**In favor: County Judge Branick, Commissioner Pierce, Commissioner Bush, Commissioner Sinegal, Commissioner Alfred**

**Action: APPROVED**

*Notice of Meeting and Agenda and Minutes  
February 15, 2022*

**COUNTY AUDITOR:**

7. Consider and approve budget transfer – Voters Registration – additional cost for postage.

120-1031-415-4052	POSTAGE	\$12,500.00	
120-1031-415-5077	CONTRACTUAL SERVICE		\$12,500.00

**SEE ATTACHMENTS ON PAGES 42 - 42**

**Motion by: Commissioner Alfred  
Second by: Commissioner Sinegal  
In favor: County Judge Branick, Commissioner Pierce, Commissioner Bush, Commissioner Sinegal, Commissioner Alfred  
Action: APPROVED**

8. Consider and approve budget transfer – District Clerk – additional cost for laptop.

120-2031-414-6002	COMPUTER EQUIPMENT	\$550.00	
120-2031-414-3078	OFFICE SUPPLIES		\$550.00

**SEE ATTACHMENTS ON PAGES 43 - 43**

**Motion by: Commissioner Alfred  
Second by: Commissioner Sinegal  
In favor: County Judge Branick, Commissioner Pierce, Commissioner Bush, Commissioner Sinegal, Commissioner Alfred  
Action: APPROVED**

9. Consider and approve electronic disbursement for \$1,249.64 to Texas Department of Criminal Justice for February insurance reimbursement.

**Motion by: Commissioner Alfred  
Second by: Commissioner Sinegal  
In favor: County Judge Branick, Commissioner Pierce, Commissioner Bush, Commissioner Sinegal, Commissioner Alfred  
Action: APPROVED**

10. Consider and approve electronic disbursement for \$934,055.86 to LaSalle for revenue received from entities for inmate housing.

**Motion by: Commissioner Alfred  
Second by: Commissioner Sinegal  
In favor: County Judge Branick, Commissioner Pierce, Commissioner Bush, Commissioner Sinegal, Commissioner Alfred  
Action: APPROVED**

*Notice of Meeting and Agenda and Minutes  
February 15, 2022*

11. Consider and approve accepting grant award modification 2 from High Density Drug Trafficking Area (HIDTA) program increasing award from \$16,200 to \$52,100, for the purchase of 2 Vigilant cameras for JCSO, award number G21HN0029A.

**SEE ATTACHMENTS ON PAGES 44 - 49**

**Motion by: Commissioner Alfred  
Second by: Commissioner Sinegal  
In favor: County Judge Branick, Commissioner Pierce, Commissioner Bush, Commissioner Sinegal, Commissioner Alfred  
Action: APPROVED**

12. Regular County Bills – check #492111 through check #492338.

**SEE ATTACHMENTS ON PAGES 50 - 59**

**Motion by: Commissioner Alfred  
Second by: Commissioner Sinegal  
In favor: County Judge Branick, Commissioner Pierce, Commissioner Bush, Commissioner Sinegal, Commissioner Alfred  
Action: APPROVED**

**COUNTY CLERK:**

13. Consider, possibly approve Congressional Resolution from United States Congress recognizing the personnel of the Jefferson County Emergency Operations Center for outstanding leadership in the Covid 19 pandemic.

**Motion by: Commissioner Pierce  
Second by: Commissioner Bush  
In favor: County Judge Branick, Commissioner Pierce, Commissioner Bush, Commissioner Sinegal, Commissioner Alfred  
Action: APPROVED**

14. Consider and possibly approve, execute, receive and file a Joint Election Agreement and Election Services Contract between Jefferson County and the City of Port Arthur for the election to be held on May 7, 2022.

**SEE ATTACHMENTS ON PAGES 60 - 74**

**Motion by: Commissioner Bush  
Second by: Commissioner Pierce  
In favor: County Judge Branick, Commissioner Pierce, Commissioner Bush, Commissioner Sinegal, Commissioner Alfred  
Action: APPROVED**

*Notice of Meeting and Agenda and Minutes  
February 15, 2022*

15. Consider and possibly approve, execute, receive and file a Joint Election Agreement and Election Services Contract between Jefferson County and Port Arthur Independent School District for the election to be held on May 7, 2022.

**SEE ATTACHMENTS ON PAGES 75 - 89**

**Motion by: Commissioner Bush**

**Second by: Commissioner Pierce**

**In favor: County Judge Branick, Commissioner Pierce, Commissioner Bush, Commissioner Sinegal, Commissioner Alfred**

**Action: APPROVED**

16. Consider and possibly approve the appointment of Central Counting Station and Early Voting Ballot Board personnel for the March 1, 2022 Joint Primary Election to include Central Counting Station Manager, Wayne Ozio; Tabulation Supervisor, Jeff Ross, Assistant Tabulation Supervisors, Mary Helm, Todd Frederick and Mike Bain; Co-Judge or Co-Chair, Clifton Simoneaux; Co-Judge or Co-Chair, John Stafford; and Early Voting Ballot Board Judge, Dina Carr.

**Motion by: Commissioner Bush**

**Second by: Commissioner Pierce**

**In favor: County Judge Branick, Commissioner Pierce, Commissioner Bush, Commissioner Sinegal, Commissioner Alfred**

**Action: APPROVED**

17. Consider and possibly approve, execute, receive and file Order Calling for a Constitutional Amendment, Special, and Joint Election to be held on May 7, 2022. the Order includes the adoption of countywide vote centers for this election. The locations and times of Early Voting and Election Day voting are also attached.

**SEE ATTACHMENTS ON PAGES 90 - 93**

**Motion by: Commissioner Bush**

**Second by: Commissioner Pierce**

**In favor: County Judge Branick, Commissioner Pierce, Commissioner Bush, Commissioner Sinegal, Commissioner Alfred**

**Action: APPROVED**



*Notice of Meeting and Agenda and Minutes  
February 15, 2022*

18. Consider and possibly approve, execute, receive and file Notice calling for a Constitutional Amendment, Special, and Joint Election for May 7, 2022.

**SEE ATTACHMENTS ON PAGES 94 - 98**

**Motion by: Commissioner Bush  
Second by: Commissioner Pierce  
In favor: County Judge Branick, Commissioner Pierce, Commissioner Bush, Commissioner Sinegal, Commissioner Alfred  
Action: APPROVED**

19. Notice of the selection and the convening of the Early Voting Ballot Board for the May 7, 2022 election.

**SEE ATTACHMENTS ON PAGES 99 - 101**

**Motion by: Commissioner Bush  
Second by: Commissioner Pierce  
In favor: County Judge Branick, Commissioner Pierce, Commissioner Bush, Commissioner Sinegal, Commissioner Alfred  
Action: APPROVED**

**COUNTY COMMISSIONERS:**

20. Consider, possibly approve, authorize the County Judge to execute, receive and file an Aerial Waiver permitting the Mosquito Control aircraft to fly at low altitudes over areas of Jefferson County pursuant to the rules and regulations governing this type of application.

**SEE ATTACHMENTS ON PAGES 102 - 102**

**Motion by: Commissioner Alfred  
Second by: Commissioner Bush  
In favor: County Judge Branick, Commissioner Pierce, Commissioner Bush, Commissioner Sinegal, Commissioner Alfred  
Action: APPROVED**

21. Consider and possibly authorize the County Judge to execute a letter of termination, requested by the City of Beaumont, for a lease between Jefferson County and the City of Beaumont for property located on Sarah and Warren Streets.

**SEE ATTACHMENTS ON PAGES 103 - 108**

**Motion by: Commissioner Alfred  
Second by: Commissioner Bush  
In favor: County Judge Branick, Commissioner Pierce, Commissioner Bush, Commissioner Sinegal, Commissioner Alfred  
Action: APPROVED**

*Notice of Meeting and Agenda and Minutes  
February 15, 2022*

22. Consider and possibly approve Jefferson County Tourism Committee Hotel Occupancy Tax allocation recommendation for an Emergency Grant for The Beaumont Panthers.

**SEE ATTACHMENTS ON PAGES 109 - 126**

**Motion by: Commissioner A ed**

**Second by: Commissioner s**

**In favor: County Judge Branick, Commissioner Pierce, Commissioner Bush, Commissioner Sinegal, Commissioner Alfred**

**Action: APPROVED**

**COUNTY TAX ASSESSOR-COLLECTOR:**

23. Consider and approve property tax refund to First Liberty National Bank in the amount of \$5,880.69 in accordance with Property Tax Code 31.11.

**SEE ATTACHMENTS ON PAGES 127 - 130**

**Motion by: Commissioner Sinegal**

**Second by: Commissioner Alfred**

**In favor: County Judge Branick, Commissioner Pierce, Commissioner Bush, Commissioner Sinegal, Commissioner Alfred**

**Action: APPROVED**

24. Consider and approve property tax refund to Delaware and Dowlen Group in the amount of \$8,873.56 in accordance with Property Tax Code 31.11.

**SEE ATTACHMENTS ON PAGES 131 - 134**

**Motion by: Commissioner Sinegal**

**Second by: Commissioner Alfred**

**In favor: County Judge Branick, Commissioner Pierce, Commissioner Bush, Commissioner Sinegal, Commissioner Alfred**

**Action: APPROVED**

## **ENGINEERING:**

25. Consider, possibly approve and authorize the County Judge to execute, receive and file an Interlocal Agreement (ILA) between Jefferson County and the Drainage District 7 (DD7) regarding the repair of the culvert crossing and Hebert Road and John's Gully, located in Precinct #3, as provided for in the construction plans and estimate in Attachment A.

**SEE ATTACHMENTS ON PAGES 135 - 143**

**Motion by: Commissioner Alfred**

**Second by: Commissioner Pierce**

**In favor: County Judge Branick, Commissioner Pierce, Commissioner Bush, Commissioner Sinegal, Commissioner Alfred**

**Action: APPROVED**

26. Execute, receive and file Pipeline Permit 01-P-22 and Road Use Agreement between Jefferson County and Kinder Morgan, for the purpose of repairing a natural gas pipeline on E. Clubb Road. This project is located in Precinct 4.

**Motion by: Commissioner Alfred**

**Second by: Commissioner Pierce**

**In favor: County Judge Branick, Commissioner Pierce, Commissioner Bush, Commissioner Sinegal, Commissioner Alfred**

**Action: APPROVED**

**SEE ATTACHMENTS ON PAGES 145 - 161**

## **Other Business:**

Receive reports from Elected Officials and staff on matters of community interest without taking action.

**\*\*\*DISCUSSION ON ANY OTHER ITEM NOT ON AGENDA WITHOUT TAKING ACTION.**

---

**Jeff R. Branick**  
**County Judge**

IFB 21-004/JW  
PO # 032909

**A505**



### Construction Contract Change Order

Grant Recipient: Jefferson County      Select:  City       County  
 Contract No.: 7218240      Change Order No.: 3      Region: SETRPC

**Contractor:**

JET Aeration of Texas, LLC  
21232 IH-10  
Vidor, TX 77662

**Engineer:**

Toby Davis, PE  
2615 Calder Avenue, Suite 500  
Beaumont, TX 77702

Select Change Order Type(s):  Change to Existing Line Items     New Items Requested     Change in Contract Duration

Grant recipient is requesting Texas Department of Agriculture review to determine eligibility of change order expenses.

**Changes to Existing Line Items (Items from original bid or added in previous change order ONLY)**

Bid Item #	Item Description	Original Qty.	Proposed Qty.	UOM	Unit Price	Δ Qty.	Change in Contract Price	+
2	Install grinder station	12	13	LS	\$5,575.00	1	\$5,575.00	-
4	Far Side Sanitary Sewer Connecti	8	9	LS	\$1,500.00	1	\$1,500.00	-
5	Abandon Existing OSSF	12	13	LS	\$250.00	1	\$250.00	-
Contract Change Sub-Total:							\$7,325.00	

**New Items Requested (Items WITHOUT a unit price in the original bid)**

Provide explanation below (attach separate documentation as appropriate). The Grant Recipient must demonstrate competitive pricing for new items.

During construction of the on-site sanitary sewer facility at two residences the Contractor demonstrated that the available circuit breaker slots within the electrical panels were non-existent, and the Contractor could not replace normal size breakers with slimline breakers. This change order will provide for new electrical subpanels at each address.

Bid Item #	Item Description	Original Qty.	Proposed Qty.	UOM	Unit Price	Δ Qty.	Change in Contract Price	+
14	Electrical subpanels		2	EA	\$963.00	2	\$1,926.00	-
Contract New Item Sub-Total:							\$1,926.00	

**Justification for Change**

	Increase	Decrease	No Change
1. Effect of this change on scope of work:	<input checked="" type="checkbox"/>	<input type="checkbox"/>	<input type="checkbox"/>
2. Effect on operation and maintenance costs:	<input type="checkbox"/>	<input type="checkbox"/>	<input checked="" type="checkbox"/>
	Yes	No	Not Applicable
3. Will this Change Order change the number of beneficiaries or TxCDBG contract Performance Statement Exhibit A?	<input type="checkbox"/>	<input checked="" type="checkbox"/>	<input type="checkbox"/>
4. Has this change created new circumstances or environmental conditions which may affect the project's impact, such as concealed or unexpected conditions discovered during actual construction?	<input type="checkbox"/>	<input checked="" type="checkbox"/>	<input type="checkbox"/>
5. Is the TCEQ clearance still valid?	<input checked="" type="checkbox"/>	<input type="checkbox"/>	<input type="checkbox"/>
6. Are other TxCDBG contractual special condition clearances still valid?	<input checked="" type="checkbox"/>	<input type="checkbox"/>	<input type="checkbox"/>
7. If new items are included that were not included in the competitive bid, have the prices been determined to be reasonable?	<input checked="" type="checkbox"/>	<input type="checkbox"/>	<input type="checkbox"/>

### Change Order Summary

Original Contract Price:	\$117,909.25	Original Contract End Date:	
Net Previous Change Order(s):	\$18,125.00	Net change of previous Change Orders (days):	
This Net Change Order:	\$9,251.00	Increase/Decrease of this Change Order (days):	
New Contract Price:	\$145,285.25	Change Order Contract End Date:	
Cumulative % Change:	23.218%		

**NOTE:** Change orders for an increase of more than 25% will be rejected. The State of Texas considers a change in the construction contract price of greater than 25% to be non-competitive, as other potential bidders did not have the opportunity to bid on the true scope of the project during the procurement process. Grant Recipient must rebid project in the event of an increase greater than 25%.

**Grant Recipient Approval (REQUIRED)**

 Authorized Signature	January 10, 2022 Date
Jeff R. Branick, Jefferson County Judge Authorized Signatory's Name and Title	

**Engineer's Recommendation**

 Engineer's Signature	1/10/2022 Date
Toby J. Davis, PE Engineer's Name	

**Contractor's Authorization**

 Contractor's Signature	2-10-22 Date
SAM STRAUD II, OWNER, Jet Aeration of Texas, LLC. Contractor's Name and Title	

To receive an email copy of the TDA response, provide contact information below

Name	Email	+
		-

**For TDA office use only**

This Net Change Order:	\$9,251.00	Increase/decrease of this Change Order (days):	n/a
Net Change Order Approved:	\$9,251.00	Increase/decrease of this Change Order Approved:	n/a
Approved Contract Amount:	\$145,285.25	Approved Contract Time:	n/a

Notes:

Beth Karwowski Contract Specialist Signature	2/9/2022 Date
---	------------------

Director Signature (optional)	Date

ATTEST *Laurie Lester*  
DATE 2-15-2022  
COUNTY CLERK - LAURIE LESTER



*Notice of Meeting and Agenda and Minutes  
January 18, 2022*

- \* 8. Consider and approve, and execute Change Order No. 3 for (IFB 21-004/JW) Phase VI: First-Time Sanitary Sewer Improvements Project for Jefferson County (Community Development Block Grant) with Jet Aeration of Texas, LLC. for an increase of \$9,251.00 for the addition of electrical subpanels required for two of the proposed installations and one additional grinder station installation; bringing the total contract from \$136,034.25 up to \$145,285.25. This project is funded by a Texas Community Development Block Grant from The Texas Department of Agriculture. (TxCDBG Contract No. 7218240); pursuant to Chapter 262, Texas Local Government Code, the County Purchasing Act and 2 CFR Sections 200.318 – 326.

SEE ATTACHMENTS ON PAGES 219 - 221

**Motion by: Commissioner Alfred**

**Second by: Commissioner Pierce**

**In favor: County Judge Branick, Commissioner Pierce, Commissioner Bush, Commissioner Sinegal, Commissioner Alfred**

**Action: APPROVED**

9. Consider and approve an agreement renewal for (Agreement 20-007/JW) with Thomson Reuters (Westlaw) for an online access subscription for Judge Milton Shuffield (Court Master). This single-user agreement is for a one-year term, at a monthly cost of \$57.00; in accordance with DIR Contract # DIR-LGL-CALIR-02 (Contract Option 1-A, Option Year 5); as shown on ATTACHMENT A.

SEE ATTACHMENTS ON PAGES 222 - 234

**Motion by: Commissioner Alfred**

**Second by: Commissioner Pierce**

**In favor: County Judge Branick, Commissioner Pierce, Commissioner Bush, Commissioner Sinegal, Commissioner Alfred**

**Action: APPROVED**

10. Consider and approve transfer of a 2013 Ford F150 truck (VIN 1FTEW1CMXDKF27384) and a 2018 Ford 15-passenger van (VIN 1FBZX2ZM3JKA32603) from the Jefferson County Women's Center to the Taylor County SATF, 1133 South 27th Street, Abilene, TX, 79605.

SEE ATTACHMENTS ON PAGES 235 - 236

**Motion by: Commissioner Alfred**

**Second by: Commissioner Pierce**

**In favor: County Judge Branick, Commissioner Pierce, Commissioner Bush, Commissioner Sinegal, Commissioner Alfred**

**Action: APPROVED**

Phone Upgrade Cable Project-Pearl Street

Quotes

Phone Upgrade Cable Project-Pearl Street

Maverick Communications		MHC DataComm,Inc		Triumph Cabling	
	Item Total		Item Total		Item Total
	\$218,653.71		\$524,000.00		\$366,765.00
<b>Total =</b>	<b>\$218,653.71</b>	<b>Total =</b>	<b>\$524,000.00</b>	<b>Total =</b>	<b>\$366,765.00</b>

Maverick Communications  
 PO Box 2233  
 Beaumont, TX 77704  
 409-840-5223 phone  
 409-840-5205 fax  
 Region V Contract

MHC DataComm Inc  
 3537 Whippoorwill St  
 Orange, TX 77603  
 409-670-1356 phone  
 225- 282-1050 fax  
[jlonglois@mhcde.com](mailto:jlonglois@mhcde.com)  
 Region V Contract

Triumph Cabling  
 17130 Groeschke Rd  
 Houston, TX 77084  
 713-465-9988 phone  
 Erik Garcia  
[egarcia@triumph-cs.com](mailto:egarcia@triumph-cs.com)  
 DIR Contract



**Phone Upgrade Project**

Quotes

		Enterprise Solutions		AT&T Business Public Sector		ConvergeOne	
			Item Total		Item Total		Item Total
Entire County Phone Upgrade			\$518,024.19		\$689,000.00		\$755,000.00
		<b>Total =</b>	<b>\$518,024.19</b>	<b>Total =</b>	<b>\$689,000.00</b>	<b>Total =</b>	<b>\$755,000.00</b>

Enterprise Solutions  
 10910 W Sam Houston Pkwy  
 Suite 500  
 Houston, TX 77064  
 Robert Hyde  
 713-343-1212 phone  
[rhyme@enter-sys.com](mailto:rhyme@enter-sys.com)  
 TIPS Contract

AT&T Business Public Sector  
 11700 Great Oaks Way  
 3rd Floor  
 Alpharetta, GA 30022  
 Alex Selem  
 470-509-5042 EXT 5620 phone  
[as1309@att.com](mailto:as1309@att.com)  
 DIR Contract

ConvergeOne  
 1820 Preston Park Blvd  
 #2800  
 Plano, TX 75093  
 Matt Mlinar  
 832-413-4059  
[MMlinar@convergeone.com](mailto:MMlinar@convergeone.com)  
 DIR Contract

## Appendix C Pricing Index (Products and Pricing)

West is the foremost provider of integrated information solutions to the U.S. legal market. West has been providing legal, government, law enforcement, and information professionals with the highest-quality legal, news, business, public records, and law enforcement information, and the most innovative technology solutions and tools to manage them, for more than 140 years.

Pursuant to the RFO, West's Contract may be extended to allow non-state Texas agencies and other states and government jurisdictions (collectively referred to in this proposal as "Other Authorized Entities") to purchase under the Contract, subject to approval by DIR and West (see page 11).

Complete product and pricing details are provided in the following pages.

### West CALIR Offerings Summary

Recognizing that Texas state and local agencies have diverse and unique online information research and solutions needs, West offers several options and packages, thus providing Texas state and local agencies with flexibility to pick and choose the option and/or package that is best suited to their specific end users' needs. West's Contract provides for three (3) different pricing options:

- **Option 1—Legal Research.** This option provides Texas agencies the ability to pick and choose from two (2) commonly requested legal research packages (Options 1A – 1B). These options also are consistent with the core legal research options offered under the existing CCG Contract. In addition, agencies may supplement these legal research packages by choosing additional content from a select list of optional separately priced add-on libraries.
- **Option 2—Investigative Research.** This option provides access to comprehensive public records, publicly available information, and proprietary data for investigative purposes. Thomson Reuters CLEAR helps law enforcement and agencies locate people faster, conduct due diligence more efficiently, and save valuable time and resources during investigations.
- **Option 3—Custom Packages.** The custom packages offered as part of this option recognize that Texas agencies may have diverse and unique needs that cannot be met by the pre-packaged content sets provided by West's Options 1 – 2. These custom packages provide maximum flexibility to purchase custom packages of legal and/or investigative online information that are specifically tailored to the unique research needs of individual agencies and end users.

In addition, West offers other similar products that might be of interest to DIR, such as legal drafting, practical law/legal know-how, print, case management, court management, continuing legal education (CLE), e-discovery, legal practice, and matter management.

### PRICING

West's content offerings provide Texas state and local agencies with cost-effective pricing for access to an extensive variety of packages of online information and functionality that assist users in their research. Given the extensive variety of options and packages available, it may be helpful to speak to a West representative who is specifically trained to help assess your agency's unique needs. To discuss content and price options best suited to your agency's needs, please contact your West government sales representative.

### AGENCY ORDERING INSTRUCTIONS

Texas state and local agencies may purchase products off the Contract by contacting their West government representative and completing the applicable West Order Form with the content/pricing option selected by the agency. Note that all POs must reference the Contract number.

## OPTION 1—LEGAL RESEARCH (PER PASSWORD)

This option provides Texas purchasing agencies the ability to pick and choose from two (2) commonly requested legal research packages (Options 1A – 1B):

- **Option 1A—Texas Core Resources with News Databases**
- Option 1B—All State and Federal Resources with News Databases

Note that these options are consistent with the core options offered under the existing CCG CALIR Contract (State Agency Options A and C, as well as Local Agency Options A and C). Texas state and local agencies that are currently accessing this content under the existing Contract will experience a seamless migration/transition process, should they decide to continue their current level of services.

Agencies may supplement these core legal research packages by choosing additional content from a select list of optional separately priced add-on libraries, including the following:

- All Analytical Library
- American Law Reports (ALR) Library
- American Jurisprudence (AMJUR) Library
- Corpus Juris Secundum (CJS) Library
- Law Reviews and Journals Library
- Municipal Practitioner Core Library
- Criminal Expert Resources
- Regulations with Editorial Enhancements (formerly RegulationsPlus)
- PeopleMap Premier
- Texas Analytical Library
- Texas Employment Practitioner Core Library
- Texas Criminal Secondary Library
- Texas Family Law Core Library
- Texas Pleadings, Motions, and Memoranda Library
- Texas Briefs Plus Library
- Texas Graphical Bundle—Graphical Statutes, PastStat Locator, and Legislative History Library
- Texas Form Finder

Pricing and descriptions of the content included for Options 1A-1B and the optional add-ons are provided in the following pages.

## STATE OF TEXAS DEPARTMENT OF INFORMATION RESOURCES CONTRACT FOR PRODUCTS AND RELATED SERVICES – DIR CONTRACT NO. DIR-LGL-CALIR-02

### LEGAL RESEARCH

#### OPTION 1A—TEXAS CORE LEGAL RESOURCES WITH NEWS DATABASES

This option provides access to core Texas primary and analytical resources, as well as news databases.

<b>Included Content:</b>	<ul style="list-style-type: none"> <li>▪ Texas Primary Law Library</li> <li>▪ Texas Practice Series Library</li> <li>▪ Texas Practice Guide Library</li> </ul>	<ul style="list-style-type: none"> <li>▪ Texas Jurisprudence Library</li> <li>▪ Employment Regulations Suite</li> <li>▪ U.S. News Library</li> </ul>					
<b>Fixed Monthly Charge:</b>	Monthly Per User Per Agency Location Pricing						
<b># of Users</b>	<b>Initial Term*</b>	<b>Year 1</b>	<b>Year 2</b>	<b>Year 3</b>	<b>Year 4</b>	<b>Option Year 5</b>	<b>Option Year 6</b>
1-25	\$47	\$47	\$49	\$52	\$54	\$57	\$60
26-50	\$45	\$45	\$47	\$49	\$52	\$54	\$57
51-100	\$42	\$42	\$45	\$47	\$49	\$52	\$54
101-150	\$40	\$40	\$42	\$44	\$47	\$49	\$51
151-200	\$38	\$38	\$40	\$42	\$44	\$47	\$49
201 +	\$36	\$36	\$38	\$40	\$42	\$44	\$46

\*Initial Term is included to cover that term from contract execution through August 31, 2017. Each subsequent year will begin September 1, in alignment with the Texas fiscal calendar. Cost of services during Initial Term and Year 1 is flat.

**Note:** Purchasing agencies with 1,000+ users may choose to contact West directly for custom pricing.

#### PACKAGE DESCRIPTION

Following are brief descriptions of the content, features, and services included in Option 1A.

##### Content

**Texas Primary Law**—Texas-specific materials, as well as federal resources concerning Texas. This library includes Texas cases, annotated statutes, administrative code, and court rules. Federal resources include federal district and circuit court decisions originating in Texas, all Supreme Court decisions, and the United States Code Annotated (USCA).

**Texas Practice Series Library**—Comprehensive reference set for Texas attorneys. Includes reference titles covering laws and rules on real property and evidence, as well as other titles such as The Jury Charge for Texas Civil Litigation and County and Special District Law.

**Texas Practice Guide Library**—Coverage of essential Texas practice areas with direct links to Texas Jurisprudence 3d, West's Texas Digest, Vernon's Texas Statutes and Codes Annotated and South Western Reporter 2d.

**Texas Jurisprudence Library**—Full text of Texas Jurisprudence, 3d.

**Employment Regulations Suite**—Texas State Office of Administrative Hearings Decisions, as well as administrative decisions and guidance documents from all 50 states. It provides a one-stop source for efficient regulatory research on employment, whether users are advising on overtime, workers' compensation, employee drug testing, or other areas of employment law.

**U.S. News Library**—Thousands of news and business information sources that offer reliable, comprehensive, and current and archival information from the United States. Sources include: newspapers, wires, news magazines, television and radio transcripts, financial news, business publications, and industry publications.

##### Features and Services

- ✓ Training (Initial and on-going at no additional charge)
- ✓ Service availability (24/7/365)
- ✓ Technical support (24/7/365)
- ✓ Research assistance (24/7/365)
- ✓ Unlimited access/usage of included content
- ✓ Unlimited download, email, print of included content
- ✓ Editorial Enhancements
- ✓ Online full-service citator and citation verification service (KeyCite, WestCheck)
- ✓ Research tools (Research Recommendations, Westlaw Answers, Snapshots)
- ✓ Analytical and organizational tools (Folder Analysis, Research Report, Custom Pages)
- ✓ Alerts\* and Current Awareness services (KeyCite Alert, WestClip) \*[Excludes daily and continuous alerts.]
- ✓ Online account management tools (My Account, QuickView+)
- ✓ Mobile access

STATE OF TEXAS DEPARTMENT OF INFORMATION RESOURCES CONTRACT FOR PRODUCTS AND RELATED SERVICES – DIR CONTRACT NO. DIR-LGL-CALIR-02

## LEGAL RESEARCH

### OPTION 1B—ALL STATE AND FEDERAL RESOURCES WITH NEWS DATABASES

This option provides access to an expanded collection of primary and analytical resources, including all state and federal, as well news databases.

<b>Included Content:</b>	<ul style="list-style-type: none"> <li>▪ All Primary Law Library</li> <li>▪ Texas Practice Series Library</li> <li>▪ Texas Practice Guide Library</li> <li>▪ Texas Jurisprudence Library</li> <li>▪ Federal Practice and Procedure Library</li> </ul>	<ul style="list-style-type: none"> <li>▪ American Jurisprudence (AMJUR) Library</li> <li>▪ Employment Regulations Suite</li> <li>▪ Regulations with Editorial Enhancements</li> <li>▪ U.S. News Library</li> </ul>					
<b>Fixed Monthly Charge:</b>	Monthly Per User Per Agency Location Pricing						
<b># of Users</b>	<b>Initial Term*</b>	<b>Year 1</b>	<b>Year 2</b>	<b>Year 3</b>	<b>Year 4</b>	<i>Option Year 5</i>	<i>Option Year 6</i>
1-25	\$77	\$77	\$81	\$85	\$89	\$94	\$98
26-50	\$73	\$73	\$77	\$81	\$85	\$89	\$93
51-100	\$69	\$69	\$73	\$77	\$80	\$84	\$89
101-150	\$66	\$66	\$69	\$73	\$76	\$80	\$84
151-200	\$63	\$63	\$66	\$69	\$73	\$76	\$80
201 +	\$60	\$60	\$63	\$66	\$69	\$72	\$76

\*Initial Term is included to cover that term from contract execution through August 31, 2017. Each subsequent year will begin September 1, in alignment with the Texas fiscal calendar. Cost of services during Initial Term and Year 1 is flat.

**Note:** Purchasing agencies with 1,000+ users may choose to contact West directly for custom pricing.

### PACKAGE DESCRIPTION

Following are brief descriptions of the content, features, and services included in Option 1B.

#### Content

**All Primary Law Library**—Federal and state case law, administrative decisions, 50 state statutes (including United States Code Annotated), and administrative rules and regulations.

**Texas Practice Series Library**—Comprehensive reference set for Texas attorneys, covering laws and rules on real property and evidence, as well as other titles such as The Jury Charge for Texas Civil Litigation and County and Special District Law.

**Texas Practice Guide Library**—Coverage of essential Texas practice areas with direct links to Texas Jurisprudence 3d, West's Texas Digest, Vernon's Texas Statutes and Codes Annotated and South Western Reporter 2d.

**Texas Jurisprudence Library**—Full text of Texas Jurisprudence, 3d.

**American Jurisprudence (AMJUR) Library**—Full text of AMJUR 2d, which provides authoritative answers to any aspect of civil, criminal, substantive, and procedural law. Cases, statutes, and regulations from all 50 states and federal courts are researched and analyzed to create Am Jur articles.

**All Federal Practice and Procedure Library**—Definitive treatise on practicing law in the federal courts.

**Employment Regulations Suite**—Texas State Office of Administrative Hearings Decisions, as well as administrative decisions and guidance documents from all 50 states. It provides a one-stop source for efficient regulatory research on employment, whether users are advising on overtime, workers' compensation, employee drug testing, or other areas of employment law.

**Regulations with Editorial Enhancements** (*formerly RegulationsPlus*)—Federal regulatory research system that helps researchers stay fully informed on regulatory issues with editorial summaries of case law decisions, notification tools, version history, and citing references.

**U.S. News Library**—Thousands of news and business information sources that offer reliable, comprehensive, and current and archival information from the United States. Sources include: newspapers, wires, news magazines, television and radio transcripts, financial news, business publications, and industry publications.

#### Features and Services

- ✓ Training (Initial and on-going at no additional charge)
- ✓ Service availability (24/7/365)
- ✓ Technical support (24/7/365)
- ✓ Research assistance (24/7/365)
- ✓ Unlimited access/usage of included content
- ✓ Unlimited download, email, print of included content
- ✓ Editorial Enhancements
- ✓ Online full-service citator and citation verification service (KeyCite, WestCheck)

- ✓ Research tools (Research Recommendations, Westlaw Answers, Snapshots)
- ✓ Analytical and organizational tools (Folder Analysis, Research Report, Custom Pages)
- ✓ Alerts and Current Awareness services (KeyCite Alert, WestClip) \*[Excludes daily and continuous alerts.]
- ✓ Online account management tools (My Account, QuickView+)
- ✓ Mobile access

STATE OF TEXAS DEPARTMENT OF INFORMATION RESOURCES CONTRACT FOR PRODUCTS AND RELATED SERVICES – DIR CONTRACT NO. DIR-LGL-CALIR-02

## LEGAL RESEARCH

### OPTION 1—OPTIONAL ADD-ON CONTENT

If an agency selects an Option 1 Legal Research package (1A – 1B), the following optional separately priced add-on libraries are available. For any add-ons selected by the agency, the corresponding monthly per-user charge will be added to the Legal Research package charge.

Optional Add-On Content (Monthly Per User Per Agency Location Pricing)							
Library Name	Initial Term*	Year 1	Year 2	Year 3	Year 4	Opt. Yr. 5	Opt. Yr. 6
All Analytical Library	\$19	\$19	\$20	\$21	\$22	\$23	\$24
American Law Reports (ALR) Library	\$11	\$11	\$12	\$12	\$13	\$13	\$14
American Jurisprudence (AMJUR) Library	\$11	\$11	\$12	\$12	\$13	\$13	\$14
Corpus Juris Secundum (CJS) Library	\$11	\$11	\$12	\$12	\$13	\$13	\$14
Law Reviews and Journals Library	\$4	\$4	\$4	\$4	\$5	\$5	\$5
Municipal Practitioner Core Library	\$11	\$11	\$12	\$12	\$13	\$13	\$14
Criminal Expert Resources	\$13	\$13	\$14	\$14	\$15	\$16	\$17
Regulations with Editorial Enhancements	\$8	\$8	\$8	\$9	\$9	\$10	\$10
PeopleMap Premier	\$75	\$75	\$79	\$83	\$87	\$91	\$96
Texas Analytical Library	\$13	\$13	\$14	\$14	\$15	\$16	\$17
Texas Employment Practitioner Core Library	\$15	\$15	\$16	\$17	\$17	\$18	\$19
Texas Criminal Secondary Library	\$12	\$12	\$13	\$13	\$14	\$15	\$15
Texas Family Law Core Library	\$11	\$11	\$12	\$12	\$13	\$13	\$14
Texas Pleadings, Motions, and Memoranda Library	\$15	\$15	\$16	\$17	\$17	\$18	\$19
Texas Briefs Plus Library	\$21	\$21	\$22	\$23	\$24	\$26	\$27
Texas Graphical Bundle—Graphical Statutes, PastStat Locator, and Legislative History Library	\$21	\$21	\$22	\$23	\$24	\$26	\$27
Texas Form Finder	\$11	\$11	\$12	\$12	\$13	\$13	\$14

\*Initial Term is included to cover that term from contract execution through August 31, 2017. Each subsequent year will begin September 1, in alignment with the Texas fiscal calendar. Cost of services during Initial Term and Year 1 is flat.

### PACKAGE DESCRIPTION

#### Content

Please see following page for brief descriptions of the content available as optional add-ons to Options 1A and 1B.

#### Features and Services

- ✓ Training (Initial and on-going at no additional charge)
- ✓ Service availability (24/7/365)
- ✓ Technical support (24/7/365)
- ✓ Research assistance (24/7/365)
- ✓ Unlimited access/usage of included content
- ✓ Download, email, print of included content
- ✓ Editorial Enhancements
- ✓ Online full-service citator and citation verification service (KeyCite, WestCheck)
- ✓ Research tools (Research Recommendations, Westlaw Answers, Snapshots)
- ✓ Analytical and organizational tools (Folder Analysis, Research Report, Custom Pages)
- ✓ Alerts and Current Awareness services (KeyCite Alert, WestClip) *\*[Excludes daily and continuous alerts.]*
- ✓ Online account management tools (My Account, QuickView+)
- ✓ Mobile access

## LEGAL RESEARCH

### OPTION 1—OPTIONAL ADD-ON CONTENT

Following are brief descriptions of the content available as optional add-on to Options 1A – 1B.

#### Content Descriptions

**All Analytical Library**—Combines expert legal analysis with forms, jury instructions, and more. Includes ALR, All AMJUR, Restatements of the Law, Federal Practice and Procedure, Causes of Action, Forms, Jury Instructions, and Law Reviews and Journals.

**American Law Reports (ALR) Library**—Leading case-finding tool in America. It is a continuing series of articles that collect and analyze every court case decided on a particular point of law. Contains full text of First, Second, Third, Fourth, Fifth, Sixth, and Federal Series.

**American Jurisprudence (AMJUR) Library**—Full text of AMJUR 2d, which provides authoritative answers to any aspect of civil, criminal, substantive, and procedural law. Cases, statutes, and regulations from all 50 states and federal courts are researched and analyzed to create Am Jur articles.

**Corpus Juris Secundum (CJS) Library**—CJS helps researchers understand unfamiliar areas of law by providing links to cases, statutes, regulations, West Key Numbers, Restatements of the Law, and more. It provides quick overviews of topics with Black Letter Summaries and is also fully integrated with the West Key Number System.

**Law Reviews and Journals Library**—Respected law reviews, law journals, and other professional legal publications.

**Municipal Practitioner Core Library**—Legal analysis, treatises, practice guides, and forms for the municipal law practitioner. This library consolidates municipal law analytical materials on Westlaw into one collection to save researchers time. It provides access to titles such as McQuillin Municipal Law Report, Matthews Municipal Ordinances, and Zoning and Planning Law Report.

**Criminal Expert Resources Library**—Essential resources for finding a criminal expert witness, including Expert, Attorney, and Judge Profiles; Expert Witness Curricula Vitae and Resumes; and Expert Witness Checklists.

**Regulations with Editorial Enhancements (formerly RegulationsPlus)**—Federal regulatory research system that helps researchers stay fully informed on any regulatory issue with editorial summaries of case law decisions, notification tools, version history, citing references and more.

**PeopleMap Premier**—comprehensive and current collection of public records and investigative information resources for locating people, assets, licenses and registrations, adverse filings, and business and corporate information. Includes advanced tools for efficient searching.

**Texas Analytical Library**—Complete collection of Texas-related legal guides, forms and authorities on topics such as on workers compensation, personal injury and torts practice, civil rules practice and more.

**Texas Employment Practitioner Core Library**—Essential employment law practice guides, forms, checklists, journals, and law reviews. Covers topics such as employment litigation, transactional and compliance topics.

**Texas Criminal Secondary Library**—Secondary materials needed for those practicing in Texas courts. Includes Texas-specific jury instructions and analytical materials, jurisdictional and national practice guides, forms and checklist, news, criminal journals, law reviews, and more.

**Texas Family Law Core Library**—Wide range of current Texas family law forms which helps users to analyze the law and evaluate legal strategy with West’s respected secondary treatises and CLE materials.

**Texas Pleadings, Motions, and Memoranda**—Selected trial pleadings, motions, and memoranda from Texas state courts. These materials provide ideas, strategies, and insight to help learn how attorneys in previous cases pled and argued similar fact situations and law.

**Texas Briefs Plus Library**—Appellate briefs filed in Texas state courts and Federal briefs from the U.S. Court of Appeals for the Fifth Circuit and U.S. Supreme Court. Provides selected trial pleadings, motions, memoranda, and jury instructions from Texas state courts, as well as pleadings, motions, and memoranda from U.S. district and bankruptcy courts within the jurisdiction of the Fifth Circuit.

**Texas Graphical Bundle—Graphical Statutes, PastStat Locator, and Legislative History Library**—Includes Graphical Statutes, PastStat Locator, and the Texas Legislative History Library.

- *Graphical Statutes.* Illustrates the evolution of statute in an easy-to-read display that incorporates the prior, current and future versions of a statute.
- *PastStat Locator.* Instant access to the statute version that was in effect on the date the legal matter actually occurred, beginning on January 1, 1999.
- *Legislative History.* Journals, floor debates, reports, bill drafts, testimony, Governor’s messages and votes.

**Texas Form Finder**—Hundreds of easily searchable official forms for Texas state, local and federal courts, as well as government agencies.

## OPTION 2—INVESTIGATIVE RESEARCH (PER PASSWORD)

This option provides access to Thomson Reuters CLEAR Investigations Basic for Texas law enforcement and for investigators in agencies and other state government offices. CLEAR Investigations Basic is an enhanced version of the previous CLEAR product West offered under the CCG Contract. It provides more content and augmented capabilities over its predecessors.

CLEAR public records data provides tremendous benefit to authorized users in locating persons and assets, verifying identities, identifying businesses and business affiliations, and uncovering potentially adverse information. CLEAR provides comprehensive data sources with current and historical data, enhanced functionality, and exclusive offerings that comprise the most comprehensive investigative platform available.

Under this plan, investigators and analysts in law enforcement and other government agencies will access and search CLEAR's public records data, publicly available data, and proprietary data via the CLEAR platform (available via web browser on computer or mobile device). Additional delivery modes for CLEAR data as well as other premium features and services are available via a CLEAR custom package plan (see Option 3, Custom Packages).

Pricing and brief descriptions of the content, features and services included in Option 2 are provided on the following page.



STATE OF TEXAS DEPARTMENT OF INFORMATION RESOURCES CONTRACT FOR PRODUCTS AND RELATED SERVICES – DIR CONTRACT NO. DIR-LGL-CALIR-02

## INVESTIGATIVE RESEARCH

### OPTION 2—CLEAR INVESTIGATIONS BASIC

2. CLEAR Investigations Basic (Monthly Per User Pricing)							
# of Users	Initial Term*	Year 1	Year 2	Year 3	Year 4	Option Year 5	Option Year 6
1-250	\$66	\$66	\$69	\$73	\$76	\$80	\$84
251-500	\$63	\$63	\$66	\$69	\$73	\$76	\$80
501-750	\$60	\$60	\$63	\$66	\$69	\$72	\$76
751+	\$57	\$57	\$59	\$62	\$66	\$69	\$72

\*Initial Term is included to cover that term from contract execution through August 31, 2017. Each subsequent year will begin September 1, in alignment with the Texas fiscal calendar. Cost of services during Initial Term and Year 1 is flat.

#### Pricing Notes:

- Tier pricing will remain fixed for the duration of the year. Tiers are based on the total number of users within an individual option and do not aggregate across other options or states. Invoices will be generated at the location level.
- Purchasing agencies with 1,000+ users may choose to contact West directly for custom pricing.

### PACKAGE DESCRIPTION

Following is a brief description of the content included in Option 2.

#### Content

**CLEAR Investigations Basic**—Provides access to CLEAR’s standard searching, reporting, and functionality. CLEAR standard search types include: Person, Business, Phone, Property, Vehicles, Watercraft, License, and Court. Also includes comprehensive Individual and Company reports, as well as more streamlined Contact and Basic reports. A dashboard provides access to tools such as Quick Analysis Flags and Address Mapping, and the Workspace feature provides link chart and mapping capabilities. (Excluded content: TransUnion credit header gateway, Vehicles gateway, Web Analytics feature.)

#### Features and Services

- ✓ Training (Initial and on-going at no additional charge)
- ✓ Service availability (24/7/365)
- ✓ Technical support (24/7/365)
- ✓ Download, email, print of included content
- ✓ Analytical and organizational tools (My Workspace)
- ✓ Online account management tools (My Account, QuickView+)
- ✓ Mobile access

### OPTION 3—CUSTOM PACKAGES

Custom packages are offered in recognition that Texas state and local agencies may have diverse and unique needs that cannot be met by the pre-packaged content sets provided by West's Options 1 and 2.

These custom packages provide purchasing agencies with maximum flexibility to purchase custom packages of online legal, investigative, law enforcement, correctional, print, and other Thomson Reuters/West products and solutions that are specifically tailored to the research needs of individual agencies and end users. Offering customized packages allows an agency to enjoy the best value, in terms of both price and content.

Pricing is not available under this option as the custom agency-specific pricing will be negotiated with the purchasing agency based on its research needs. Please contact your local West government representative for more information about these custom plans and to obtain your discount. West can also provide agencies with free trial access.

## OTHER SIMILAR PRODUCTS OFFERED BY VENDOR

In addition to our core offerings, West offers additional products that may be of interest to DIR, such as legal drafting, practical law/legal know-how, case management, court management, continuing legal education (CLE), e-discovery, legal practice, and matter management. West also offers an expansive print collection, and print discounts might be available for eligible agencies. (Please note that some of our print discount plans are not packaged with online offerings.)

Please see your local West government representative for more information regarding any of these additional products.

## Vendor Standard Terms and Conditions

The following terms and conditions apply to purchases made under this Contract for authorized/eligible State of Texas Department of Information Resources (hereinafter “DIR”) Customers.

- **Eligibility**—Available only to authorized Texas state and local agencies as agreed upon by the terms of the Contract negotiated between the Texas Department of Information Resources (“DIR”) and West Publishing Corporation (“West”). The following entities are eligible to purchase CALIR products and services under this Contract (Bid Package 4, Appendix A, Subsection 3(A), as amended by Exhibit A):

“Customer - any Texas state agency, unit of local government, institution of higher education as defined in Section 2054.003, Texas Government Code, the Electric Reliability Council of Texas, the Lower Colorado River Authority, a private school, as defined by Section 5.001, Education Code, a private or independent institution of higher education, as defined by Section 61.003, Education Code, a volunteer fire department, as defined by Section 152.001, Tax Code, and those state agencies purchasing from a DIR contract through an Interagency Agreement, as authorized by Chapter 771, Texas Government Code, any local government as authorized through the Interlocal Cooperation Act, Chapter 791, Texas Government Code, and the state agencies and political subdivisions of other states as authorized by Section 2054.0565, Texas Government Code, subject to West’s approval, and except for telecommunications services under Chapter 2170, Texas Government Code.”

Please note: West does not agree to allow entities as defined in Sections B-J of Bid Package 4, Appendix A, Subsection 3(B-J) to purchase products and services under this contract.

The rates set forth hereunder are available only to authorized state and local government personnel accessing West products for government purposes.

Pursuant to the RFO, West’s contract may be extended to other non-Texas state agencies and political subdivisions of other states, subject to West’s approval.

- **Agency/Purchasing Agency Locations**—Each purchasing agency location must subscribe separately (for Options 1 and 2). Access is limited to the agency’s personnel at that location. Purchasing agencies with multiple locations may purchase under Option 3 (Custom Packages).
- **Authorized Users**—Only users authorized to use West products by the purchasing agency may access and use West products under the terms of this agreement, and such use must be solely for purposes directly related to the purchasing agency’s research and work.
- **Passwords**—Each user must be assigned a separate password. Passwords may only be used by the person to whom the password is issued. Sharing of passwords between or among users is STRICTLY PROHIBITED. West reserves the right to issue additional passwords to the purchasing agency and invoice the Password Rate if West learns that the product has been used by a person other than the person to whom the password has been issued.
- **Password Rates**—The Monthly Charge per User under each option will NOT be prorated. Requests for passwords by new Subscribers or requests for additional passwords by current Subscribers that are processed by West by the last day of a month will be billed the entire Monthly Charge per User for each password request during such month. The Monthly Charge per User for Subscribers that elect to change from one option to another will be effective on the first day of the month following receipt and approval of the appropriate documentation by West.
- **Included and Excluded Charges**—Purchasing agencies will receive the content package as described in their West Order Form. Access to and usage of any other databases, features, and services is excluded and will be billed separately as excluded charges. The excluded content, features, and services will be charged at the applicable rates (including applicable transaction, communications, and other associated charges, if any) for each database, feature, or service accessed according to the then-current terms and conditions as set forth in

the then-current Schedule A Plan 2 Westlaw Government Service or Schedule A Plan 2 Westlaw PRO (Westlaw), or the then-current CLEAR Services Schedule A (CLEAR).

West may, at its option, make certain databases, features, and services excluded charges if West is contractually bound or otherwise required to do so by a contributor of data to West, or if the databases, features, and services are enhanced or released after the effective date of any contract awarded to West pursuant to this Response. Purchasing entities will receive online notification and may have the option to change plans or terminate if a material change is made.

- **CLEAR Usage**—West’s proposal allows for CLEAR usage up to ten times the proposed fixed-rate guarantee. (Usage will be calculated using then-current retail rates.) In the event the purchasing agency’s CLEAR usage exceeds this limit during any month of the proposed contract term, West may, at its option, (1) limit the purchasing agency’s access to live gateways for the remainder of the contract term, (2) request that the parties enter into good faith negotiations for an adjusted fixed rate, or (3) terminate the contract (after providing ten days written notice to the purchasing agency).
- **New Databases, Features, Services, and Platforms**—West reserves the right to charge for any new databases, features, services, or platforms released during the term of this contract (whether “third-party” databases or not), and such charges may be separate from and in addition to the Fixed Monthly Charge. Such charges (if any) shall not be greater than the charges at which such databases, features, services, or platforms are made available to West’s other government subscribers under West’s then-current Schedule A Plan 2 Westlaw Government Service (Westlaw) or CLEAR Services Schedule A (CLEAR).

If, however, any new databases, features, services, or platforms released during the term of this contract are made generally available to government subscribers as part of their fixed rate agreement, West will also make these same new databases, features, services, or platforms available to the purchasing agency at no extra cost.

- **Ordering Documents**—The attached West Order Form and license agreement (General Terms and Conditions--Thomson Reuters Legal Products and Services) provide complete details regarding West’s offer. These documents will be incorporated by reference into and made part of any contract awarded to West. In addition, access to and usage of CLEAR requires completion of the then-current Account Validation and Certification (AVC) Form. (Current copies of these documents are included in Appendix D.)
- **Contractor Information**—Any contract resulting from this proposal will be with:

<b>Legal Contracting Entity:</b>	West Publishing Corporation
<b>Doing Business As (DBA):</b>	West, a Thomson Reuters business
<b>Corporate Address:</b>	610 Opperman Drive, Eagan, MN 55123
<b>Remittance Address:</b>	P.O. Box 6292, Carol Stream, IL 60197-6292
<b>Federal Tax ID #:</b>	41-1426973
<b>DUNS #:</b>	14-850-8286
<b>Cage Code:</b>	89101

- **Ordering Instructions**—Authorized purchasing agencies may purchase products off the Contract by contacting their West government representative and completing the applicable West Order Form and any necessary credentialing documents, and attaching the applicable West Order Form with the content/pricing option selected by the purchasing agency. Note that all Order Forms must reference the State Contract number and the Option(s) selected.
- **Signature Requirements**— The applicable Order Form and any related documentation must be signed by an authorized representative. In lieu of a signed Order Form, an agency must submit a Purchase Order that contains the following incorporating clause: “This Purchase Order incorporates the attached West Order Form made pursuant to the DIR Contract No. DIR-LGL-CALIR-02.”

- **Order Processing**—Orders will be processed as follows:
  - **Options 1 and 2:** Service will begin 5-7 days following receipt of a fully executed, clean, and process-able West Order Form, and after any necessary credentialing has been completed.
  - **Option 3:** Service will begin the first day of the first month following receipt of the fully executed West Order Form and after any necessary credentialing has been completed, provided adequate time is available for implementing the contract. In general, to implement a contract, West must receive the fully executed, applicable West Order Form no later than five business days prior to the end of the month preceding the start of service.

Orders received that do not follow these guidelines will not be accepted or will delay processing.

- **Survivability**—At the time of expiration or cancellation of the Contract, any existing multi-year agreement between West and a purchasing agency will remain in effect and continue to exist under the terms and conditions of the Contract, including payment for services, until the term expires as set forth in the multi-year agreement.

## **SOFTWARE LICENSE AGREEMENTS AND SAMPLE ORDERING DOCUMENTS**

Copies of West's software license agreements and ordering documents/forms are part of Appendix D.

**WEST ORDER FORM**

610 Opperman Drive, P.O. Box 64833  
 St. Paul, MN 55164-1803  
 Tel: 651/687-8000



THOMSON REUTERS

<b>Check West account status below as applicable:</b>		Rep Name & Number <u>Rachel Cicero 0169133</u>	
New <input type="checkbox"/> (NACI Form attached)	Existing with Increase Credit Limit <input type="checkbox"/> (NACI Form attached)		
Existing with no changes <input checked="" type="checkbox"/>	Existing with changes <input type="checkbox"/> (Permanent name change must attach a Customer Name Change Form)		
Acct # <u>1000648463</u>	Quote # _____	PO # _____	Date <u>2/4/2022</u>
Name/Customer <u>JEFFERSON COUNTY COURT LAW 1</u>		Bill To Acct # <u>1000648463</u>	
Order Confirmation Contact Name <u>Effie Rojo</u>			
E-Mail <u>erojo@co.jefferson.tx.us</u>			
Password Contact Name (for password delivery) <u>Effie Rojo</u>			
E-Mail <u>erojo@co.jefferson.tx.us</u>			
Time and Billing Contact Name <u>Effie Rojo</u>			
E-Mail <u>erojo@co.jefferson.tx.us</u>			
Federal Government Account Type	Non-FEDLINK <input type="checkbox"/>	FEDLINK <input type="checkbox"/>	GSA <input type="checkbox"/>
MSA Jurisdiction <u>Texas SAID TXMS</u>	Contract # <u>DIR-LGL-CALIR-02</u>	Option # <u>1A</u>	
Permanent Address Change <input type="checkbox"/>		One-Time Ship To <input type="checkbox"/>	Additional Ship To <input type="checkbox"/>
Additional Bill To <input type="checkbox"/>		Name _____ Attn: _____	
Address _____		Suite/Floor _____	
City _____	State _____	County _____	Zip _____

\*\*\* R E Q U I R E D \*\*\*  
  
I F N E E D E D

This Order Form is a legal document between Customer and

- A. West Publishing Corporation to the extent that products or services will be provided by West Publishing Corporation, and/or
- B. Thomson Reuters Enterprise Centre GmbH to the extent that products or services will be provided by Thomson Reuters Enterprise Centre GmbH.

A detailed list of products and services that are provided by Thomson Reuters Enterprise Centre GmbH and current applicable IRS Certification forms are available at: <https://www.tr.com/trorderinginfo>

West Publishing Corporation may also act as an agent on behalf of Thomson Reuters Enterprise Centre GmbH solely with respect to billing and collecting payment from Customer. Thomson Reuters Enterprise Centre GmbH and West Publishing Corporation will be referred to as "Thomson Reuters", "we" or "our," in each case with respect to the products and services it is providing, and Customer will be referred to as "you", "your", "I" or "Client".

**Thomson Reuters General Terms and Conditions**, apply to all products ordered, except print and is located at <http://tr.com/TermsandConditions>. The Thomson Reuters General Terms and Conditions for Federal Customers is located at [legalsolutions.com/Federal-ThomsonReuters-General-Terms-Conditions.pdf](http://legalsolutions.com/Federal-ThomsonReuters-General-Terms-Conditions.pdf). In the event that there is a conflict of terms between the Thomson Reuters General Terms and Conditions and this Order Form, the terms of this Order Form control. This Order Form is subject to our approval.

Online/CD-ROM/Practice Solutions/Software Products							
Full Svc #	Online/CD-ROM/Practice Solutions/Software Products	Quantity *	Monthly Rate Banded/Base Rate	Per User/Conc. User Rate	Other	Total Monthly Charges	Minimum Term (Months)
	TX MSA OPTION 1A	1		57			12

\* Fill in the maximum number of Passwords, Users, Seats, FTEs, Students, Terminals, CD/Concurrent Patron Users, Active Legal Holds, and Quantity of Additional Storage

**Total Monthly Charges (initial Term) \$ 57**

**Online/Practice Solutions/Software Products Subscriptions**

Your subscription is effective upon the date we process your order ("Effective Date") and Monthly Charges will be prorated for the number of days remaining in that month, if any. Your subscription will continue for the number of months listed in the Minimum Term column above counting from the first day of the month following the Effective Date. Your Monthly Charges during the first twelve (12) months of the Minimum Term are as set forth above. If your Minimum Term is longer than 12 months, then your Monthly Charges for each year of the Minimum Term are displayed in the Pricing Attachment (#1113) to the Order Form.

When your Minimum Term terminates, the following will apply:

**Government Customers Post-Minimum Term.** At the end of the Minimum Term, your Monthly Charges will increase by 7%. Thereafter, the Monthly Charges will increase 7% every 12 months unless we notify you of a different rate at least 90 days before the annual increase. Either of us may cancel the Post-Minimum Term subscription by sending at least 60 days written notice.

**Federal Government Customers Optional Minimum Term.** Federal government customers that chose a multi-year term, may exercise the option to implement those additional years pursuant to federal law.

**Automatic Renewal Term for Non-Government Customers Only.** If you are a non-government customer, your subscription will automatically renew at the end of the Minimum Term. Each Automatic Renewal Term will be 12 months in length ("Automatic Renewal Term") and include a 7% price increase unless we notify you of a different rate at least 90 days before each Automatic Renewal Term begins. as defined below. Either of us may cancel in writing at least 60 days before an Automatic Renewal Term starts.

**CD-ROM and Dissomaster Products**

Monthly Charges begin on the date we process your order and will be prorated for the number of days remaining in that calendar month, if any. Your Monthly Charges will continue for a Minimum Term of the following 12 complete calendar months. If you have an existing Per User CD-ROM license and are adding additional users with this Order Form, the Minimum Term in your underlying Order Form will apply.

During your subscription terms, you will receive subscription services consisting of automatic shipments of updates, replacement or supplemental CD-ROMs and online updates.

*W* **Initials for Post Minimum Term Subscription Services.** I understand that West will continue to provide subscription services for the products listed above after the Minimum Term. At the end of the Minimum Term, your Monthly Charges will be billed at up to our then current retail rate.

Your West sales representative will provide frequency of updates upon request. For transportation charges, returns and refunds see Miscellaneous below.

Either of us may cancel effective at the end of the Minimum Term or any time thereafter on at least 60 days written notice.

*N/A* **Annual billing (please check if requested)**

**Banded Products Subscriptions**

You certify your total number of attorneys (partners, shareholders, associates, contract or staff attorneys, of counsel, and the like), corporate users, personnel or full-time-equivalent students is indicated in this Order Form. Our pricing for banded products is made in reliance upon your certification. If we learn that the actual number is greater or increases at any time, we reserve the right to increase your charges as applicable.

**Internal Corporate Use Only**  **BND**

**Technical Contacts for Westlaw Patron Access and Campus Research**

Technical Contact Name (please print): \_\_\_\_\_

Telephone: \_\_\_\_\_

E-Mail Address: \_\_\_\_\_

Current Account #: \_\_\_\_\_

Patron Access: IP Address: \_\_\_\_\_

One IP Address per terminal. Additional pages may be attached if needed.

Campus Research: IP Address Range \_\_\_\_\_

\* Orders submitted without IP Address information may delay set up and access

**For Internal Office Use Only**

**OF Instructions:** Max Concu = # of terms/Eml to WTC/Blk Ancil/1 term = 5 atty = 1 pw/Tech cont = 59



	<b>Print/CD-ROM Products</b>	
--	------------------------------	--

Identify which Westlaw password holder you would like to have Quickview+ access:

Last Name \_\_\_\_\_ First Name \_\_\_\_\_ E-mail \_\_\_\_\_

Full Svc #	Print/CD-ROM Products	Quantity	List Charges	Other	Unit Price	Charges	Print Subscription Service (y/n)

Notes: \_\_\_\_\_

**Total Charges \$** \_\_\_\_\_

**N/A Initial for Subscription Services.** I understand that West will continue to provide subscription services for the print and/or CD-ROM products designated above. Print and/or CD-ROM subscription services include automatic shipments. For print subscriptions you will receive automatic shipments of updates and supplements, such as pocket parts, pamphlets, replacement volumes or loose-leaf pages and will be billed or auto-charged or debited (if separately authorized) at our then current rates. Anniversary billed print products (annual billed and monthly billed) will be billed at then current rates. Monthly anniversary billed products will be billed monthly at then current rates. For CD-ROM subscriptions you will receive automatic shipments of updates and supplements and will be billed or auto-charged or debited (if separately authorized) at our then current rate.

Your West sales representative will provide frequency of updates upon request. Transportation charges, return and refund information is in the Miscellaneous section below.

Subscription services will continue until cancelled by either party at any time in writing. Send your notice of cancellation to Customer Service, 610 Opperman Drive, P.O. Box 64833, Eagan MN 55123-1803.

	<b>Online/CD-ROM Products to be Lapsed</b>	
--	--	--

Full Svc #	Online/CD-ROM Products	# of Passwords

Notes: \_\_\_\_\_

	<b>Westlaw Roaming Access</b>	
--	-------------------------------	--

If you access Westlaw regulated data, you receive roaming access by default. Roaming access permits users located outside your designated IP address range to access Westlaw regulated data. We may block roaming access at our option. You may choose to block roaming access by initialing below.

\_\_\_\_\_ **Initial to block roaming access**

	<b>Miscellaneous</b>	
--	----------------------	--

1. **Applicable Law.** If you are a state or local governmental entity, your state's law will apply and any claim may be brought in the state or federal courts located in your state. If you are a non-governmental entity, this Order Form will be interpreted under Minnesota state law and any claim by one of us may be brought in the state or federal courts in Minnesota. If you are a United States Federal Government customer, United States federal law will apply and any claim may be brought in any federal court.

2. **Excluded Charges.** If you access Westlaw data or Practice Solutions services that are not included in your subscription you will be charged our then current rate. Excluded Charges will be invoiced and due with your next payment. For your reference, the current Excluded Charges schedules are located at <http://static.legalsolutions.thomsonreuters.com/static/agreement/schedule-a-westlaw.pdf> and <http://legalsolutions.com/schedule-a-concourse-firm-central-caseologistix>. Excluded Charges may change after at least 30 days written or online notice.

- 3. **Charges, Payments & Taxes.** You agree to pay all charges in full within 30 days of the date of invoice. You are responsible for any applicable sales, use, value added tax (VAT), etc. unless you are tax exempt. If you are a non-government customer and fail to pay your invoiced charges, you are responsible for collection costs including attorneys' fees.
- 4. **Credit Verification.** If you are applying for credit as an individual, we may request a consumer credit report to determine your creditworthiness. If we obtain a consumer credit report, you may request the name, address and telephone number of the agency that supplied the credit report. If you are applying for credit on behalf of a business, we may request a current business financial statement from you to consider your request.
- 5. **Returns and Refunds.** You may return a print or CD-ROM product to us within 45 days of the original shipment date if you are not completely satisfied. Assured Print Pricing, Library Savings Plan, West Complete, Library Maintenance Agreements, ePack, WestPack, Westlaw, CLEAR, Monitor Suite, ProView eBook, Software, West LegalEdcenter, Practice Solutions, TREWS, Peer Monitor and Data Privacy Advisor charges are not refundable. Please see <http://static.legalsolutions.thomsonreuters.com/static/returns-refunds.pdf> or contact Customer Service at 1-800-328-4880 for additional details regarding our policies on returns and refunds.
- 6. **Cancellation Notice.** Send your notice of cancellation to Customer Service, 610 Opperman Drive, P.O. Box 64833, Eagan, MN 55123-1803.
- 7. **Transportation Charges.** Print and CD-ROM products are shipped F.O.B. origin. Transportation charges will be added for expedited shipments made at your request and for international product delivery. Expedited shipments and international product shipments will be charged at the then current carrier rate.
- 8. **Product Specific Terms.** The following products have specific terms which are incorporated by reference and made part of this Order Form if they apply to your order. They can be found at [legalsolutions.com/ThomsonReuters-General-Terms-Conditions-PST.pdf](http://legalsolutions.com/ThomsonReuters-General-Terms-Conditions-PST.pdf). If the product is not part of your order, the product specific terms do not apply. If there is a conflict between product specific terms and the Order Form, the product specific terms control.

- Campus Research
- CD-ROM
- Contract Express
- Hosted Practice Solutions
- ProView eBooks
- Time and Billing
- West km software
- West LegalEdcenter
- Westlaw
- Westlaw Doc & Form Builder
- Westlaw Paralegal
- Westlaw Patron Access
- Westlaw Public Records

ATTEST Laurie Hess  
DATE 2-15-2022



**ACKNOWLEDGMENT**

I warrant that I am authorized to accept these terms and conditions on behalf of Customer .

Printed Name Jeff R. Branick  
 Title Jefferson County Judge  
 Date February 15, 2022  
 Signature  [Signature]

<b>For Credit Card Transactions only:</b>	Visa _____ Expir. _____ Date _____	Master Card _____ Total Amt. to Charge for this Order _____	Am Ex _____	
Card # _____	Subscription charges for this order will be billed to your West account unless automatic credit card or electronic funds transfers have been separately authorized.			

For Internal Use Only (Rep to complete for telephone print orders only)

By signing and completing below the Rep certifies that he/she discussed and received assent to the Subscription Services terms above from Customer.

Date: \_\_\_\_\_ Time: \_\_\_\_\_

Name of Customer Placing Order: \_\_\_\_\_

Signature of Rep: \_\_\_\_\_



This Task Order is made part of and governed by the terms and provisions of the contract by and between Tidal Basin Government Consulting, LLC (Tidal Basin), and Jefferson County, TX (the "County") following our response to RFP 21-024/YS. The purpose of this task order is for Tidal Basin to provide grant management advice at the discretion of the County. Advice given could result in the County applying to the Hazard Mitigation Grant Program (HMGP).

**Project Name:** Jefferson County, TX Grant Management

**Scope of Services/Rates:** Tidal Basin agrees to perform the following scope of services in accordance with the payment basis, estimated quantity of services and estimated cost of services set forth below. Tidal Basin shall not perform services which exceed the estimated cost of services without prior written notice to and approval by the County. Services and hours performed outside the scope of this task order will not be reimbursed.

Tidal Basin will provide consulting services to deliver the following on behalf of the County:

Tidal Basin will identify, organize, and compile the information necessary to deliver the best grants management advice:

- Grants Management Advice:
  - Gather data and coordinate with the County to advice on grants at their discretion
  - Provide progress reports on hours worked
  - Coordinate and reach out to homeowners
  - Compile data and preform benefit cost analysis as needed
  - Complete project applications for HMA grants
  - Compile data needed to fulfill FEMA requests for information

**Payment Basis:** Rates will be reimbursed in accordance with Attachment 1. The estimated costs are as follows:

Position	Rate	Hours	Cost Per Position
Subject Matter Expert	\$185.00	37	\$6,845.00
Consultant	\$165.00	80	\$13,200.00
Hours Subtotal		117	\$20,045.00
<b>Total Estimated NTE</b>			<b>\$20,045.00</b>

**Estimated Quantity of Services:** Please see above. Personnel will work at the direction of Tidal Basin's Project Manager.



**Estimated Cost of Services:** The total cost of this task order shall not exceed **\$20,045.00**. If hours are to be exceeded Tidal Basin will inform the County and coordinate further task orders as needed

**Approval/Acceptance**

Acceptance of the terms of this task order is acknowledged by the following signatures of the authorized representatives of the parties to the agreement.

Tidal Basin Government Consulting, LLC

Jefferson County, Texas

By: [Signature]

By: [Signature]

Name: LUIS AVILA

Name: Jeff Branick

Title: VICE PRESIDENT, MITIGATION

Title: County Judge

Date: 2-9-2022

Date: 02/15/2022

**Attachment 1 - Pricing**

Hazard Mitigation Assistance	
Project Manager	\$255
Subject Matter Expert	\$185
Consultant	\$165

Pricing presented is based on hourly rates in accordance with the existing contract. All expenses will be charged to the client in accordance with the GSA rate schedule associated with the area of operations. No current expenses are forecasted, TB will gain preapproval from County if needed.



ATTEST [Signature]  
DATE 2-15-2022



**JEFFERSON COUNTY PURCHASING DEPARTMENT**  
*Deborah Clark, Purchasing Agent*

---

1149 Pearl Street, Beaumont, TX 77701 Phone: 409-835-8593 Fax: 409-835-8456

**MEMORANDUM**

To: Commissioners' Court

From: Deborah Clark  
Purchasing Agent

A handwritten signature in blue ink, appearing to be "DC", is written over the name "Deborah Clark" in the "From:" field.

Date: February 10, 2022

Re: Surplus Property Auction

Consider and possibly approve an auction of surplus property as authorized by Local Government Code §263.152 (a) (1) by Horn's Auction, Inc. The auction is schedule for Saturday, March 5, 2022 at 9:00 A.M.

Thank you.

JEFFERSON COUNTY, TEXAS  
 1149 PEARL STREET  
 BEAUMONT, TX 77701

SURPLUS PROPERTY SALE  
 HORN AUCTION

March 5, 2022

DEPARTMENT	DESCRIPTION OF PROPERTY	SERIAL NO.	ASSET NO.
AGRICULTURE	SMALL GREEN CHAIR		16207
AGRICULTURE	SMALL ROLLING TABLE		16226
<i>contact person: Jennifer Coleman</i>			
HISTORICAL COMMISSION	HP DESIGNJET T1100 PS MODEL: Q6713A	MY8BB6C081	34510
HISTORICAL COMMISSION	STAND	DK8914F02B	
<i>contact person: Sylvia Moore</i>			
DISTRICT CLERK	SAFE		12697
<i>contact person: Sylvia Moore</i>			

Approved by Commissioners' Court: \_\_\_\_\_



**JEFFERSON COUNTY PURCHASING DEPARTMENT  
AUCTION OF SURPLUS PROPERTY**

Date: 01-20-22

Department: Sheriff

Contact Person: Dana Agullard

Phone: 409-835-8734

Fax: 409-720-4031

Department Head Approval: *[Signature]*

Approved in Com. Court: \_\_\_\_\_

Description of Property	Serial No.	Asset No.	Condition of Property
See Attached List		All - None	All - Good

## Auction Items

- 18 Wheeler - 5th Wheel attachment (mil)
- 2- Tractor Supply Fuel Tanks - Truck bed mount with pumps and nozzles
- 2- Boat Propellers new in box
- 3 - Used propellers
- Powder Coat Light Stand and blue storage box
- 2-300 HP Evinrude Boat Motors Model #- E300ZUABA SN-05421285  
Model #- E300ZCUAB SN-05437372
- 1- 300 HP Yamaha Boat Motor. Model #-LF300UCA. SN-6CFU1003512
- 1- McCulloch generator Model FG5700 AK SN- unreadable
- Truck Bed Mounted Winch Crane Unit  
Thorn Model 5124  
SN-5010-53606
- Box of New Brake Pads- Part # 200222 Shoe and Lining Brake
- Air Conditioner (MIL) Portable  
Model FDECU-2  
MFR 94833  
NSN 4120-01-449-0459  
Part Number 98750ASSY9454100  
SN 982878
- 1-Marathon Electric Motor (New in Box) 5KC49PN0155A SN-K16J30007
- 20 Foot Monark Boat Hull number MAK403040587  
motor 125 HP Mercury SN-OT470699  
trailer 1M5BA202GC1F74599
- 25 foot Sea Ark Boat Hull number SAMA1090L999  
motor Yamaha SN-6P2X1017841 Model F250 TXR  
motor Yamaha SN-6P3X100859\_ Model LF250 TXR  
trailer 42XBB2633YF008570
- Air Compressor Mi-T-M Corporation  
AM2-P305-30K  
SN- 20086970



## Marine unit

## Additional Items for Auction Approval

1. Furuno Radar Display	RDP-149	4345-8757
2. Furuno Radar Display	RDP-149	4345-9909
3. Furuno Radar Processor	RPU-015	4324-5863
4. Furuno LCD Display	MU-155C	8046-2435 (no box)
5. Furuno Radar Antenna	RSB-0071	R170-4436
6. Furuno Radar Antenna	RSB-0071	R170-????
7. Furuno Radar Antenna	RSB-0071	R170-9370
8. Furuno Heading Sensor	PG-500	3488-7692
9. Furuno Heading Sensor	PG-500	3488-7442
10. Furuno Heading Sensor	PG-500	3488-8159
11. Furuno GPS Receiver	GP-320B	44447-???8
12. Furuno GPS Receiver	GP-320B	4447-5316
13. Furuno GPS Receiver	GP-320B	4447-766
14. Air Mar Depth Transducer	SS555	1247481
15. Furuno Network Sounder	DFF1	8856-1831
16. Furuno Navnet Control Unit	RCU-017	7437
17. ICOM AIS Receiver	MXA-5000	0103846
18. ICOM AIS Receiver	MXA-5000	0103843
19. Furuno Radar	H5B-0071	8170-8499

ITEMS 20-28 are all Sonar System components

20. IDX Company Battery Charger	VL-2 Plus	K1-14522
21. Didson-DH	100M	459
22. Didson-DH	100M	456
23. General Dynamics Laptop	IX270	ZZSJC9301ZZ1021
24. Cobra DC to Ac Invertor	CPI475	808070925
25. AC adapter- Delta Electric	ADP-90SBBB	VCW0725015899
26. ASTEC AC adapter	DPS55	E585F600170AJH
27. Protek Power Supply	PUP120-16-B1	144150
28. Hummingbird GPS Monitor	1197CNVB	9061102-0224
29. Mounting Arm/Bracket	No Model #	No Serial #

**Fran Lee**

---

**From:** Terry Wuenschel <twuenschel@co.jefferson.tx.us>  
**Sent:** Tuesday, February 8, 2022 9:27 AM  
**To:** Fran Lee  
**Cc:** Cheryl Ellis; Allison Getz  
**Subject:** 2021-2022 Voter Budget Transfer

Fran,

Please transfer \$12,500 from Contractual Service 1031-415-5077 to Postage 1031-415-4052 to cover postage shortage due to increased postal rates. We will not need to use \$12,500 allocated for contract labor.

Thank you,

*Terry Wuenschel, PCC*  
*Chief Deputy Assessor-Collector*  
**Jefferson County Tax Office**  
**P: 409-835-8704; F: 409-835-8589**  
**[twuenschel@co.jefferson.tx.us](mailto:twuenschel@co.jefferson.tx.us)**  
**[www.jeffcotax.com](http://www.jeffcotax.com)**

CONFIDENTIALITY NOTICE:

-----  
THIS TRANSMISSION IS INTENDED FOR THE SOLE USE OF THE INDIVIDUAL AND/OR ENTITY TO WHOM IT IS ADDRESSED, AND MAY CONTAIN INFORMATION AND/OR ATTACHMENTS THAT ARE PRIVILEGED, CONFIDENTIAL AND EXEMPT FROM DISCLOSURE UNDER APPLICABLE LAW. IF YOU ARE NOT THE INTENDED RECIPIENT, YOU ARE HEREBY NOTIFIED THAT ANY DISCLOSURE, DISSEMINATION, DISTRIBUTION, DUPLICATION OR THE TAKING OF ANY ACTIONS IN RELIANCE ON THE CONTENTS OF THIS TRANSMISSION BY SOMEONE OTHER THAN THE INTENDED ADDRESSEE OR ITS DESIGNATED AGENT IS STRICTLY PROHIBITED. IF YOU HAVE RECEIVED THIS MESSAGE IN ERROR, PLEASE NOTIFY THE SENDER BY REPLYING IMMEDIATELY AND DELETE THE MESSAGE.

**Jefferson County  
District Clerk's Office**  
1085 Pearl Street  
Room 203  
Beaumont, TX 77701  
409-835-8580  
Fax 409-835-8527



**Family Law Division**  
409-835-8653

**Child Support**  
P. O. Box 3586  
Beaumont, TX 77704  
409-835-8425

**Jamie Smith  
District Clerk**

Dear Fran,

I am requesting to transfer \$550.00 from account 120-2031-414-30-78 (office supplies) to account 120-2031-414-60-02 (capital outlay/computer equipment) for the purchase of a laptop.

Respectfully,

A handwritten signature in cursive script that reads "Jamie Smith".

Jamie Smith  
Jefferson County District Clerk



February 1, 2022

Judge Jeff Branick  
County of Jefferson  
1149 Pearl Street, 7th Floor  
Beaumont, TX 77701-3600

Dear Judge Branick:

Grant number G21HN0029A has been increased and now totals \$52,100.00.

The original of Modification 2 is enclosed. If you accept this Modification, sign the Modification and return a copy to the Assistance Center in Miami. Keep the original Modification for your file.

All terms and conditions of the original award apply to the Modification. If you have any questions pertaining to this grant award, please contact Jayme Delano at (202) 395 - 6794.

Sincerely,

A handwritten signature in cursive script that reads "Shannon J. Kelly".

Shannon Kelly  
National HIDTA Director

Enclosures

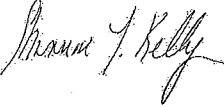
<b>Executive Office of the President Office of National Drug Control Policy</b>		<b>AWARD Grant</b>	Page 1 of 1
1. Recipient Name and Address Judge Jeff Branick County of Jefferson 1149 Pearl Street 7th Floor Beaumont, TX 77701-3600		4. Award Number: G21HN0029A	
		5. Grant Period: From 01/01/2021 to 12/31/2022	
1A. Subrecipient IRS/Vendor No.	6. Date: 2/1/2022	7. Action	
Subrecipient Name and Address	8. Supplement Number 2	Initial	
		<input checked="" type="checkbox"/> Supplemental	
2A. Subrecipient IRS/Vendor No.:	9. Previous Award Amount:	\$16,200.00	
3. Project Title	10. Amount of This Award:	\$35,900.00	
South East Texas Drug Enforcement Task Force	11. Total Award:	\$52,100.00	
12. • The above grant is approved subject to such conditions or limitation as are set forth in the original Grant.			
13. Statutory Authority for Grant: Public Law 116-260 H.R.133			
<b>AGENCY APPROVAL</b>		<b>RECIPIENT ACCEPTANCE</b>	
14. Typed Name and Title of Approving Official Shannon Kelly National HIDTA Director	15. Typed Name and Title of Authorized Official Jeff Branick Judge		
16. Signature of Approving ONDCP Official 	17. Signature of Authorized Recipient/Date		
<b>AGENCY USE ONLY</b>			
18. Accounting Classification Code DUNS: 010807535 EIN: 1746000291A3	19. HIDTA AWARD OND1070DB2122XX      OND6113 OND2000000000      OC 410001 JID: 77756		

# Initiative Cash by HIDTA

FY 2021

Current Budget (net of reprogrammed funds)

HIDTA	Agency Name	Initiative	Cash	Type	Grant
Houston	County of Jefferson	South East Texas Drug Enforcement Task Force	52,100.00	Investigation	G21HN0029A
Agency Total : County of Jefferson			<b>52,100.00</b>		

**Total**

**52,100.00**

# Budget Detail

2021 - Houston

Initiative - South East Texas Drug Enforcement Task Force



Investigation

Award Recipient - County of Jefferson (G21HN0029A)

Resource Recipient - Jefferson County

*Indirect Cost: 0.0%*

<b>Equipment</b>		
	<b>Quantity</b>	<b>Amount</b>
Equipment		\$35,900.00
<b>Total Equipment</b>		<b>\$35,900.00</b>
<b>Total Budget</b>		<b>\$35,900.00</b>

		<b>Vigilant Solutions, LLC</b> 1152 Stealth Street Livermore, California 94551 (P) 925-398-2079 (F) 925-398-2113			
Issued To:	Jefferson County Sheriff - Attention: Jake Droddy	Date:	01-07-22		
Project Name:	Jefferson County Sheriff- 2(2) Mobile LPR	Quote ID:	MKT-0163-01		

## **PROJECT QUOTATION**

We at Vigilant Solutions, LLC are pleased to quote the following systems for the above referenced project:

Qty	Item #	Description
(2)	Mobile LPR SYS-1 CDM-2-33--RHD	<b>Mobile LPR 2-Camera Reaper High-Definition System (Expandable to 4 Cams)</b> <u>Hardware:</u> <ul style="list-style-type: none"> <li>• Qty=2 12mm lens package</li> <li>• VLP-5200 Processing Unit</li> <li>• Wiring harness w/ ignition control (Direct to Battery)               <ul style="list-style-type: none"> <li>◦ Single point power connection</li> </ul> </li> <li>• Field installed GPS antenna</li> </ul> <u>Software:</u> <ul style="list-style-type: none"> <li>• CarDetector Mobile LPR software application for MDC unit               <ul style="list-style-type: none"> <li>◦ LPR vehicle license plate scanning / real time alerting</li> <li>◦ Full suite of LPR tools including video tool set</li> </ul> </li> </ul>
(4)	K-U-R-TAHOE-SET	<b>LPR Camera Mounting Kit for 2015 Tahoe Roof</b> <ul style="list-style-type: none"> <li>• Roof Mount Single LPR Camera Mounting Bracket - One per camera</li> </ul>
(1)	VSBSVC-01	<b>Vigilant LPR Basic Service Package for Hosted/Managed LPR Deployments</b> <ul style="list-style-type: none"> <li>• Managed/hosted server account services by Vigilant               <ul style="list-style-type: none"> <li>◦ Includes access to all LEARN or Client Portal and CarDetector software updates</li> </ul> </li> <li>• Priced per camera per year for up to 14 total camera units registered</li> <li>• Requires new/existing Enterprise Service Agreement (ESA)</li> </ul>
(2)	SSU-SYS-COM	<b>Vigilant System Start Up &amp; Commissioning of 'In Field' LPR system</b> <ul style="list-style-type: none"> <li>• Vigilant technician to visit customer site</li> <li>• Includes system start up, configuration and commissioning of LPR system</li> <li>• Includes CDM/CDF Training</li> <li>• Applies to mobile (1 System) and fixed (1 Camera) LPR systems</li> </ul>
(1)	VS-TRVL-01	<b>Vigilant Travel via Client Site Visit</b> <ul style="list-style-type: none"> <li>• Vigilant certified technician to visit client site</li> <li>• Includes all travel costs for onsite support services</li> </ul>



(2)	VS-SHP-01	<b>Vigilant Shipping Charges - Mobile</b> <ul style="list-style-type: none"> <li>• Applies to each Mobile LPR System</li> <li>• Shipping Method is FOB Shipping</li> </ul>
<b>Subtotal Price</b> (Excluding sales tax)		<b>\$27,500.00</b>

### Additional Options

Qty	Item #	Description
(2)	CDMS24HWW	<b>2-Camera Mobile LPR System - Extended Hardware Warranty - Years 2 through 5</b> <ul style="list-style-type: none"> <li>• Full mobile LPR hardware component replacement warranty</li> <li>• Applies to 2-Camera hardware system kit</li> <li>• Valid for 4 years from standard warranty expiration</li> </ul>
<b>Subtotal Price</b> (Excluding sales tax)		<b>\$8,400.00</b>

#### Quote Notes:

1. All prices are quoted in USD and will remain firm and in effect for 60 days.
2. Returns or exchanges will incur a 15% restocking fee.
3. Orders requiring immediate shipment may be subject to a 15% QuickShip fee.
4. Installation not included

Quoted by: Madison Touchette - 925-398-2079 - [madison.touchette@motorolasolutions.com](mailto:madison.touchette@motorolasolutions.com)

<b>Total Price</b>	<b>\$35,900.00</b>	(Excluding sales tax) (Including All Adds)
--------------------	--------------------	---

NAME	AMOUNT	CHECK NO.	TOTAL
ROAD & BRIDGE PCT.#1			
SPIDLE & SPIDLE	4,460.58	492116	
ART SIGNS & DECALS	165.00	492121	
M&D SUPPLY	12.08	492153	
RALPH'S INDUSTRIAL ELECTRONICS	26.70	492166	
SOUTHERN TIRE MART, LLC	180.22	492199	
ATTABOY TERMITE & PEST CONTROL	10.30	492250	
JEFFERSON COUNTY CREDIT CARDS	89.98	492257	
FUNCTION 4 LLC	31.00	492295	4,975.86**
ROAD & BRIDGE PCT.#2			
ENTERGY	598.44	492144	
AT&T	102.63	492181	
FUNCTION 4 LLC	31.00	492295	732.07**
ROAD & BRIDGE PCT. # 3			
BEAUMONT TRACTOR COMPANY	120.75	492123	
CITY OF PORT ARTHUR - WATER DEPT.	43.37	492132	
FARM & HOME SUPPLY	8.79	492138	
ENTERGY	400.75	492144	
MUNRO'S	492.87	492155	
RITTER @ HOME	481.44	492165	
W. JEFFERSON COUNTY M.W.D.	27.67	492194	
WINDSTREAM	43.13	492239	
ON TIME TIRE	172.99	492265	
SMITTY'S HAMSHIRE GULF	69.00	492288	
FUNCTION 4 LLC	62.00	492295	
ALL TERRAIN EQUIPMENT CO	56.85	492299	1,979.61**
ROAD & BRIDGE PCT.#4			
CLASSIC CHEVROLET	90.11	492111	
RB EVERETT & COMPANY, INC.	399.11	492137	
ENTERGY	17.65	492144	
M&D SUPPLY	275.68	492153	
MUNRO'S	147.72	492155	
OFFICE DEPOT	65.77	492158	
SMART'S TRUCK & TRAILER, INC.	135.00	492174	
SOUTHEAST TEXAS WATER	12.95	492177	
UNDERGROUND INC.	884.85	492227	
FUNCTION 4 LLC	52.00	492295	
WAUKESHA-PEARCE INDUSTRIES LLC	94.97	492297	
REXEL USA INC	1,241.46	492303	
O'REILLY AUTO PARTS	.00	492307	
LINDENMEYR MUNROE	146.68	492325	3,563.95**
ENGINEERING FUND			
TEXAS FLOODPLAIN MGMT. ASSN.	50.00	492191	
JEFFERSON COUNTY CREDIT CARDS	679.64	492257	
FUNCTION 4 LLC	62.00	492295	
CHAPMAN VENDING	251.52	492327	1,043.16**
PARKS & RECREATION			
CITY OF PORT ARTHUR - WATER DEPT.	33.64	492132	
ENTERGY	51.74	492144	
RITTER @ HOME	179.98	492165	
W. JEFFERSON COUNTY M.W.D.	27.67	492194	
LOWE'S HOME CENTERS, INC.	128.91	492220	
JEFFERSON COUNTY CREDIT CARDS	3,164.00	492257	
PRO CHEM INC	693.41	492269	
ALL TERRAIN EQUIPMENT CO	303.64	492299	4,582.99**
GENERAL FUND			
TAX OFFICE			
OFFICE DEPOT	169.94	492158	
PITNEY BOWES, INC.	1,308.00	492162	

NAME	AMOUNT	CHECK NO.	TOTAL
ACE IMAGEWEAR	39.42	492173	
SOUTHEAST TEXAS WATER	295.00	492176	
UNITED STATES POSTAL SERVICE	1,961.40	492211	
UNITED STATES POSTAL SERVICE	171.01	492212	
NEMO-Q	520.00	492275	
PURCHASE POWER	1,527.82	492287	
DESIGN CHUTE LLC	755.03	492289	
FUNCTION 4 LLC	155.00	492295	6,902.62*
COUNTY HUMAN RESOURCES			
UNITED STATES POSTAL SERVICE	1.45	492211	
FUNCTION 4 LLC	31.00	492295	32.45*
AUDITOR'S OFFICE			
OFFICE DEPOT	11.43	492158	
SOUTHEAST TEXAS WATER	34.95	492178	
UNITED STATES POSTAL SERVICE	17.96	492211	
FUNCTION 4 LLC	31.00	492295	72.48*
COUNTY CLERK			
KIRKSEY'S SPRINT PRINTING	79.60	492152	
OFFICE DEPOT	19.99	492158	
UNITED STATES POSTAL SERVICE	223.21	492211	
UNITED STATES POSTAL SERVICE	129.80	492212	
SIERRA SPRING WATER CO. - BT	63.91	492214	
FUNCTION 4 LLC	433.00	492295	949.51*
COUNTY JUDGE			
WELLS PEYTON & PARTAIN, LLP	500.00	492120	
LINDA F PATTERSON	1,732.50	492160	
KEVIN PAULA SEKALY PC	500.00	492171	
UNITED STATES POSTAL SERVICE	.92	492211	
JEFFERSON COUNTY CREDIT CARDS	129.90	492257	
FUNCTION 4 LLC	31.00	492295	2,894.32*
RISK MANAGEMENT			
UNITED STATES POSTAL SERVICE	4.78	492211	
KRISTEN HANCOCK	58.25	492218	
FUNCTION 4 LLC	31.00	492295	94.03*
COUNTY TREASURER			
TAC - TEXAS ASSN. OF COUNTIES	275.00	492183	
TAC - TEXAS ASSN. OF COUNTIES	215.00	492184	
UNITED STATES POSTAL SERVICE	134.36	492211	
FUNCTION 4 LLC	62.00	492295	686.36*
PRINTING DEPARTMENT			
FUNCTION 4 LLC	350.00	492295	350.00*
PURCHASING DEPARTMENT			
CINTAS CORPORATION	38.91	492286	
FUNCTION 4 LLC	31.00	492295	69.91*
GENERAL SERVICES			
ELECTRICAL SPECIALTIES, INC.	25.00	492113	
TIME WARNER COMMUNICATIONS	2,442.76	492186	
TEXAS WILDLIFE DAMAGE MGMT FUND	2,700.00	492188	
INTERFACE EAP	1,328.40	492197	
ADVANCED STAFFING	97.50	492200	
LAMAR UNIVERSITY - DEPT. OF COMM.	12,499.00	492204	
VERIZON WIRELESS	265.93	492208	
MCGRIFF, SEIBELS & WILLIAMS OF TX	5,638.00	492223	
NETCJCA	175.00	492260	
K2 TOWERS III, LLC	2,435.00	492333	27,606.59*
DATA PROCESSING			

NAME	AMOUNT	CHECK NO.	TOTAL
CDW COMPUTER CENTERS, INC.	3,413.70	492203	
JEFFERSON COUNTY CREDIT CARDS	232.85	492257	
FUNCTION 4 LLC	31.00	492295	3,677.55*
VOTERS REGISTRATION DEPT			
UNITED STATES POSTAL SERVICE	1,464.64	492211	
FUNCTION 4 LLC	31.00	492295	1,495.64*
ELECTIONS DEPARTMENT			
UNITED STATES POSTAL SERVICE	815.67	492211	
SIERRA SPRING WATER CO. - BT	29.43	492214	
JEFFERSON COUNTY CREDIT CARDS	90.14	492257	
AT&T MOBILITY	510.59	492285	
FUNCTION 4 LLC	31.00	492295	1,476.83*
DISTRICT ATTORNEY			
JEFFERSON CTY. DISTRICT ATTORNEY	16,100.00	492149	
UNITED STATES POSTAL SERVICE	224.95	492211	
FUNCTION 4 LLC	155.00	492295	16,479.95*
DISTRICT CLERK			
CASH ADVANCE ACCOUNT	1,790.20	492151	
UNITED STATES POSTAL SERVICE	261.37	492211	
FUNCTION 4 LLC	31.00	492295	2,082.57*
CRIMINAL DISTRICT COURT			
TODD W LEBLANC	600.00	492114	
DAVID GROVE	8,750.00	492117	
THOMAS J. BURBANK PC	4,287.50	492127	
CRISTY SMITH	155.20	492128	
DONALD W. DUESLER & ASSOC.	8,750.00	492136	
EDWARD B. GRIPON, M.D., P.A.	1,785.00	492143	
MARSHA NORMAND	8,750.00	492156	
OFFICE DEPOT	133.75	492158	
KEVIN PAULA SEKALY PC	8,750.00	492171	
RENE MULHOLLAND	439.70	492193	
KEVIN S. LAINE	4,375.00	492201	
LANGSTON ADAMS	800.00	492222	
JOEL WEBB VAZQUEZ	2,362.50	492230	
JAMES R. MAKIN, P.C.	562.50	492261	
WILLIAM MARCUS WILKERSON	900.00	492271	
FUNCTION 4 LLC	62.00	492295	
MARVIN LEWIS JR	3,300.00	492309	54,763.15*
58TH DISTRICT COURT			
UNITED STATES POSTAL SERVICE	1.83	492211	
FUNCTION 4 LLC	31.00	492295	32.83*
60TH DISTRICT COURT			
OFFICE DEPOT	70.00	492158	
FUNCTION 4 LLC	31.00	492295	101.00*
136TH DISTRICT COURT			
LEXIS-NEXIS	80.00	492213	
FUNCTION 4 LLC	31.00	492295	111.00*
172ND DISTRICT COURT			
UNITED STATES POSTAL SERVICE	7.22	492211	
LEXIS-NEXIS	80.00	492213	
FUNCTION 4 LLC	31.00	492295	118.22*
252ND DISTRICT COURT			
THOMAS J. BURBANK PC	800.00	492127	

NAME	AMOUNT	CHECK NO.	TOTAL
KEVIN S. LAINE	4,375.00	492201	
UNITED STATES POSTAL SERVICE	46.17	492211	
BRITTANIE HOLMES	1,387.50	492270	
FUNCTION 4 LLC	62.00	492295	
279TH DISTRICT COURT			6,670.67*
RANDY SHELTON	250.00	492172	
JOEL WEBB VAZQUEZ	220.00	492230	
TONYA CONNELL TOUPS	110.00	492243	
BRITTANIE HOLMES	550.00	492270	
THOMSON REUTERS-WEST	278.00	492273	
WILLIAM FORD DISHMAN	990.00	492276	
MATUSKA LAW FIRM	110.00	492278	
FUNCTION 4 LLC	31.00	492295	
317TH DISTRICT COURT			2,539.00*
SAM HOUSTON STATE UNIVERSITY	275.00	492167	
TEXAS ASSN. FOR COURT ADMINISTRATIO	75.00	492185	
JONATHAN L. STOVALL	300.00	492259	
BRITTANIE HOLMES	300.00	492270	
FUNCTION 4 LLC	31.00	492295	
JUSTICE COURT-PCT 1 PL 1			981.00*
OFFICE DEPOT	176.07	492158	
TAC - TEXAS ASSN. OF COUNTIES	230.00	492182	
UNITED STATES POSTAL SERVICE	16.19	492211	
FUNCTION 4 LLC	31.00	492295	
JUSTICE COURT-PCT 1 PL 2			453.26*
UNITED STATES POSTAL SERVICE	36.42	492211	
FUNCTION 4 LLC	31.00	492295	
JUSTICE COURT-PCT 4			67.42*
JEFFERSON COUNTY CREDIT CARDS	315.00	492257	
FUNCTION 4 LLC	31.00	492295	
JUSTICE COURT-PCT 6			346.00*
OFFICE DEPOT	18.99	492158	
TEXAS STATE UNIVERSITY SAN MARS	75.00	492180	
UNITED STATES POSTAL SERVICE	9.30	492211	
FUNCTION 4 LLC	31.00	492295	
DIRECTV, LLC	75.47	492336	
JUSTICE OF PEACE PCT. 8			209.76*
UNITED STATES POSTAL SERVICE	284.80	492212	
FUNCTION 4 LLC	31.00	492295	
COUNTY COURT AT LAW NO.1			315.80*
UNITED STATES POSTAL SERVICE	1.38	492211	
LEXIS-NEXIS	83.00	492213	
SIERRA SPRING WATER CO. - BT	43.93	492215	
THOMSON REUTERS-WEST	164.00	492273	
FUNCTION 4 LLC	31.00	492295	
COUNTY COURT AT LAW NO. 2			323.31*
TODD W LEBLANC	250.00	492114	
JACK LAWRENCE	250.00	492118	
DONALD BOUDREAUX	600.00	492125	
THOMAS J. BURBANK PC	250.00	492127	
NATHAN REYNOLDS, JR.	250.00	492164	
TEXAS COURT REPORTERS ASSOCIATION	165.00	492190	
UNITED STATES POSTAL SERVICE	6.92	492211	
LANGSTON ADAMS	400.00	492222	
JOEL WEBB VAZQUEZ	250.00	492230	

NAME	AMOUNT	CHECK NO.	TOTAL
TURK LAW FIRM	250.00	492272	
MATUSKA LAW FIRM	250.00	492278	
JARED GILTHORPE	250.00	492279	
FUNCTION 4 LLC	31.00	492295	
LAW OFFICE OF GILES R COLE & ASSOC	300.00	492326	
THE WALKER LAW FIRM	650.00	492331	
COUNTY COURT AT LAW NO. 3			4,152.92*
TODD W LEBLANC	750.00	492114	
THOMAS J. BURBANK PC	250.00	492127	
KIRKSEY'S SPRINT PRINTING	19.25	492152	
NATHAN REYNOLDS, JR.	250.00	492164	
UNITED STATES POSTAL SERVICE	9.22	492211	
SIERRA SPRING WATER CO. - BT	23.51	492216	
LANGSTON ADAMS	300.00	492222	
JOEL WEBB VAZQUEZ	250.00	492230	
TURK LAW FIRM	1,150.00	492272	
JARED GILTHORPE	500.00	492279	
FUNCTION 4 LLC	31.00	492295	
COURT MASTER			3,532.98*
UNITED STATES POSTAL SERVICE	.73	492211	
FUNCTION 4 LLC	31.00	492295	
MEDIATION CENTER			31.73*
UNITED STATES POSTAL SERVICE	12.45	492211	
FUNCTION 4 LLC	31.00	492295	
COMMUNITY SUPERVISION			43.45*
FUNCTION 4 LLC	124.00	492295	
SHERIFF'S DEPARTMENT			124.00*
FED EX	37.47	492140	
W.W. GRAINGER, INC.	78.12	492142	
ENTERGY	1,001.02	492144	
KIRKSEY'S SPRINT PRINTING	24.95	492152	
MOORMAN & ASSOCIATES, INC.	1,435.00	492154	
OFFICE DEPOT	1,726.07	492158	
PUBLIC AGENCY TRAINING COUNCIL	350.00	492163	
SAM'S WESTERN WEAR, INC.	404.50	492169	
AT&T	172.16	492181	
CDW COMPUTER CENTERS, INC.	90.72	492203	
UNITED STATES POSTAL SERVICE	915.17	492211	
BEAUMONT OCCUPATIONAL SERVICE, INC.	244.65	492219	
JEFFERSON COUNTY CREDIT CARDS	1,895.25	492257	
RITA HURT	275.00	492263	
TRANSUNION RISK AND ALTERNATIVE	575.00	492281	
GALLS LLC	11.00	492283	
FUNCTION 4 LLC	310.00	492295	
TND WORKWEAR CO LLC	48.00	492296	
VECTOR SECURITY	116.55	492298	
BLUE360 MEDIA	795.60	492300	
FANNETT VETERINARY CLINIC	92.00	492305	
NEIGHBORHOOD VETERINARY CENTERS	24.60	492320	
CRIME LABORATORY			10,622.83*
OFFICE DEPOT	171.08	492158	
CLEAN HARBORS ENVIRONMENTAL SERVICE	82.46	492225	
CAYMAN CHEMICAL COMPANY	366.00	492252	
JEFFERSON COUNTY CREDIT CARDS	70.11	492257	
FUNCTION 4 LLC	31.00	492295	
VECTOR SECURITY	163.80	492298	
CHEMTEQ INC	104.76	492304	
WORKQUEST	130.00	492329	
JAIL - NO. 2			1,119.21*

NAME	AMOUNT	CHECK NO.	TOTAL
MARK'S PLUMBING PARTS	723.28	492112	
BOB BARKER CO., INC.	1,671.28	492122	
CITY OF BEAUMONT - WATER DEPT.	26.00	492131	
DESSER TIRE & RUBBER COMPANY	1,650.00	492135	
W.W. GRAINGER, INC.	3,075.28	492142	
ENTERGY	34,799.74	492144	
HERTZ CORPORATION	201.05	492147	
JACK BROOKS REGIONAL AIRPORT	2,298.88	492150	
KIRKSEY'S SPRINT PRINTING	24.95	492152	
M&D SUPPLY	19.95	492153	
OFFICE DEPOT	604.29	492158	
OVERHEAD DOOR CO.	304.25	492159	
AT&T	30.33	492181	
WHOLESALE ELECTRIC SUPPLY CO.	56.94	492195	
LOWE'S HOME CENTERS, INC.	1,074.92	492220	
INTERCONTINENTAL JET CORP	2,328.05	492232	
WORLD FUEL SERVICES	3,309.39	492251	
EPIC CARD SERVICES LLC	300.00	492268	
FUNCTION 4 LLC	217.00	492295	
TND WORKWEAR CO LLC	120.95	492296	
LASALLE CORRECTIONS VI LLC	40,348.00	492308	
TRINITY SERVICES GROUP INC	26,295.55	492315	
VICTORY SUPPLY LLC	5,298.30	492316	
SPINDLETOP PLUMBING	19,950.03	492335	
			144,728.41*
JUVENILE PROBATION DEPT.			
FED EX	3.57	492139	
UNITED STATES POSTAL SERVICE	8.11	492211	
LYNN BIERHALTER	81.90	492238	
TANISHA GRIFFIN	167.90	492280	
ROXANA MITCHELL	358.61	492284	
SUMMER KENNERSON	111.15	492290	
FUNCTION 4 LLC	93.00	492295	
SHERONDA LEE	60.84	492302	
JAMIE GROGAN	227.57	492319	
			1,112.65*
JUVENILE DETENTION HOME			
ENTERGY	3,536.94	492144	
FLOWERS FOODS	99.65	492228	
BEN E KEITH FOODS	3,001.48	492229	
FUNCTION 4 LLC	31.00	492295	
			6,669.07*
CONSTABLE PCT 1			
UNITED STATES POSTAL SERVICE	99.46	492211	
FUNCTION 4 LLC	31.00	492295	
			130.46*
CONSTABLE-PCT 4			
DISH NETWORK	72.69	492241	
FUNCTION 4 LLC	31.00	492295	
			103.69*
CONSTABLE-PCT 6			
UNITED STATES POSTAL SERVICE	9.10	492211	
GALLS LLC	26.98	492283	
FUNCTION 4 LLC	31.00	492295	
			67.08*
CONSTABLE PCT. 7			
JEFFERSON COUNTY CREDIT CARDS	158.20	492257	
			158.20*
CONSTABLE PCT. 8			
FUNCTION 4 LLC	31.00	492295	
			31.00*
AGRICULTURE EXTENSION SVC			
FUNCTION 4 LLC	31.00	492295	
			31.00*
HEALTH AND WELFARE NO. 1			

NAME	AMOUNT	CHECK NO.	TOTAL
BROUSSARD'S MORTUARY	4,800.00	492126	
CLAYBAR HAVEN OF REST	4,160.00	492209	
UNITED STATES POSTAL SERVICE	71.26	492211	
RACHEL DRAGULSKI	111.00	492221	
PROCTOR'S MORTUARY INC	3,000.00	492253	
FUNCTION 4 LLC	62.00	492295	
EZEA D EDE MD	2,932.58	492324	
HEALTH AND WELFARE NO. 2			15,136.84*
O.W. COLLINS APARTMENTS	90.00	492133	
GABRIEL FUNERAL HOME, INC.	1,647.00	492141	
MCKESSON MEDICAL-SURGICAL INC	435.31	492205	
UNITED STATES POSTAL SERVICE	411.84	492212	
FUNCTION 4 LLC	62.00	492295	
EZEA D EDE MD	2,932.58	492324	
JAMES "DAVID" WINFIELD	16.38	492328	
NURSE PRACTITIONER			5,595.11*
FUNCTION 4 LLC	31.00	492295	
ENVIRONMENTAL CONTROL			31.00*
FUNCTION 4 LLC	31.00	492295	
INDIGENT MEDICAL SERVICES			31.00*
LOCAL GOVERNMENT SOLUTIONS LP	3,773.00	492244	
CARDINAL HEALTH 110 INC	19,626.36	492274	
CORLISS R RANDLE	1,200.00	492311	
MICHAEL BARNES	1,200.00	492334	
MAINTENANCE-BEAUMONT			25,799.36*
JOHNSTONE SUPPLY	123.04	492119	
M&D SUPPLY	482.13	492153	
SANITARY SUPPLY, INC.	250.00	492170	
ACE IMAGEWEAR	208.40	492173	
S.E. TEXAS BUILDING SERVICE	25,381.80	492175	
AT&T	668.56	492181	
WORTH HYDROCHEM	265.00	492196	
TEXAS FIRE & COMMUNICATIONS	8,495.00	492207	
AT&T GLOBAL SERVICES	3,099.00	492224	
CENTERPOINT ENERGY RESOURCES CORP	8,978.03	492233	
INTERSTATE ALL BATTERY CENTER - BMT	79.98	492249	
JEFFERSON COUNTY CREDIT CARDS	30.00	492257	
FUNCTION 4 LLC	31.00	492295	
MAINTENANCE-PORT ARTHUR			48,091.94*
TRIANGLE LOCKSMITH	205.00	492115	
OFFICE DEPOT	139.22	492158	
SANITARY SUPPLY, INC.	145.04	492170	
SMART'S TRUCK & TRAILER, INC.	59.83	492174	
S.E. TEXAS BUILDING SERVICE	8,774.98	492175	
HOWARD'S AUTO SUPPLY	85.91	492202	
LOWE'S HOME CENTERS, INC.	53.58	492220	
CHRISTOPHER ELECTRIC INC	329.95	492245	
ATTABOY TERMITE & PEST CONTROL	103.53	492250	
PARKER LUMBER	381.62	492255	
JEFFERSON COUNTY CREDIT CARDS	59.62	492257	
PRO CHEM INC	379.00	492269	
FUNCTION 4 LLC	93.00	492295	
VECTOR SECURITY	1,810.00	492298	
BE'S SMALL ENGINE SERVICES	185.00	492313	
MAINTENANCE-MID COUNTY			12,805.28*
ENTERGY	3,079.17	492144	
JEFFERSON COUNTY CREDIT CARDS	179.25	492257	
FUNCTION 4 LLC	31.00	492295	
SERVICE CENTER			3,289.42*



NAME	AMOUNT	CHECK NO.	TOTAL
SPIDLE & SPIDLE	20,938.32	492116	
J.K. CHEVROLET CO.	28.28	492148	
PHILPOTT MOTORS, INC.	113.68	492161	
AT&T	68.42	492181	
S.E. TEXAS AUTO EQUIPMENT	861.56	492198	
VOYAGER FLEET SYSTEM, INC.	20,613.14	492226	
BUMPER TO BUMPER	306.31	492231	
AIRPORT GULF TOWING LLC	125.00	492236	
ROBERT'S TEXACO XPRESS LUBE	112.00	492246	
AMERICAN TIRE DISTRIBUTORS	596.56	492247	
EASTEX PRESSURE WASHERS	247.50	492264	
CINTAS CORPORATION	88.83	492286	
MIDNIGHT AUTO	199.99	492291	
FUNCTION 4 LLC	31.00	492295	
THIS GUYS TOOLS, LLC	151.00	492312	
VETERANS SERVICE			44,481.59*
UNITED STATES POSTAL SERVICE	18.62	492211	
FUNCTION 4 LLC	62.00	492295	
PANORAMIC VETPRO INC	2,250.00	492332	
			2,330.62*
			462,154.07**
MOSQUITO CONTROL FUND			
BIOQUIP PRODUCTS	50.96	492124	
ENTERGY	651.31	492144	
MUNRO'S	71.94	492155	
TIME WARNER COMMUNICATIONS	65.83	492187	
FUNCTION 4 LLC	31.00	492295	
O'REILLY AUTO PARTS	69.74	492307	
JCN OIL SERVICE	125.00	492321	
ES OPCO USA LLC	120,581.20	492323	
FEMA EMERGENCY			121,646.98**
DRAINAGE DISTRICT # 6	286,956.49	492134	
BREATH ALCOHOL TESTING			286,956.49**
CMI INC	400.86	492130	
FAMILY GROUP CONFERENCING			400.86**
FUNCTION 4 LLC	31.00	492295	
J.C. FAMILY TREATMENT			31.00**
ACE RENTAL MANAGEMENT, LLC	200.00	492338	
SECURITY FEE FUND			200.00**
OFFICE DEPOT	106.77	492158	
ALLIED UNIVERSAL SECURITY SERVICES	8,182.46	492318	
LAW LIBRARY FUND			8,289.23**
FUNCTION 4 LLC	31.00	492295	
EMPG GRANT			31.00**
SOUTHEAST TEXAS WATER	28.95	492179	
TEXAS CORRECTIONAL INDUSTRIES	400.00	492189	
JEFFERSON COUNTY CREDIT CARDS	590.02	492257	
FUNCTION 4 LLC	31.00	492295	
GRANT A STATE AID			1,049.97**
SAM HOUSTON STATE UNIVERSITY	530.00	492168	
BI INCORPORATED	130.54	492206	
YOUTH ADVOCATE PROGRAMS INC	6,308.75	492242	
RITE OF PASSAGE	451.04	492322	
COMMUNITY SUPERVISION FND			7,420.33**

NAME	AMOUNT	CHECK NO.	TOTAL
TDCJ - CASHIERS OFFICE	218,213.98	492129	
OFFICE DEPOT	110.54	492158	
UNITED STATES POSTAL SERVICE	109.99	492211	
UNITED STATES POSTAL SERVICE	360.80	492212	
US POSTAL SERVICE	69.60	492217	
LOCAL GOVERNMENT SOLUTIONS LP	6,965.00	492244	
JEFFERSON COUNTY CREDIT CARDS	270.00	492257	
JCCSC	225.00	492258	
PRINTMAILPRO.COM	218.00	492266	
FUNCTION 4 LLC	263.50	492295	
			226,806.41**
JEFF. CO. WOMEN'S CENTER			
CENTERPOINT ENERGY RESOURCES CORP	173.99	492233	
			173.99**
COMMUNITY CORRECTIONS PRG			
JEFFERSON COUNTY CREDIT CARDS	629.10	492257	
FUNCTION 4 LLC	31.00	492295	
			660.10**
DRUG DIVERSION PROGRAM			
FUNCTION 4 LLC	31.00	492295	
			31.00**
LAW OFFICER TRAINING GRT			
W.W. GRAINGER, INC.	55.80	492142	
ENTERGY	408.74	492144	
OFFICE DEPOT	5.54	492158	
PRINT JUNKIES INK	2,040.00	492282	
IMAGE 360 BEAUMONT	67.66	492306	
IHEART MEDIA	3,000.00	492337	
			5,577.74**
J.P. COURTROOM TECH. FUND			
CDW COMPUTER CENTERS, INC.	968.02	492203	
			968.02**
HOTEL OCCUPANCY TAX FUND			
MUNRO'S	105.49	492155	
AT&T	119.64	492181	
ULINE SHIPPING SUPPLY SPECIALI	751.98	492192	
FUNCTION 4 LLC	31.00	492295	
KIMBERLY BROWN	250.00	492330	
			1,258.11**
DISTRICT CLK RECORDS MGMT			
FUNCTION 4 LLC	62.00	492295	
			62.00**
AIRPORT FUND			
BEAUMONT TRACTOR COMPANY	2.16	492123	
ENTERGY	16,012.69	492146	
RALPH'S INDUSTRIAL ELECTRONICS	214.78	492166	
AT&T	371.22	492181	
LOWE'S HOME CENTERS, INC.	351.13	492220	
BUMPER TO BUMPER	109.08	492231	
DISH NETWORK	116.70	492240	
ROBERT'S TEXACO XPRESS LUBE	7.00	492246	
ARNOLD AND ASSOCIATES	2,000.00	492248	
JEFFERSON COUNTY CREDIT CARDS	659.94	492257	
DELTA INDUSTRIAL SERVICE & SUPPLY	1,833.16	492262	
SOUTHEAST TEXAS PARTS AND EQUIPMENT	57.33	492277	
FUNCTION 4 LLC	62.00	492295	
TITAN AVIATION FUELS	115,230.52	492310	
THE HOME DEPOT PRO	1,418.86	492314	
			138,446.57**
AIRPORT IMPROVE. GRANTS			
GARVER LLC	1,740.00	492254	
			1,740.00**
SE TX EMP. BENEFIT POOL			

NAME	AMOUNT	CHECK NO.	TOTAL
STANDARD INSURANCE COMPANY	25,895.28	492235	
RELIANCE STANDARD LIFE INSURANCE	6,045.08	492237	
EXPRESS SCRIPTS INC	190,520.68	492301	
CORLISS R RANDLE	19,200.00	492311	
UNITED HEALTHCARE SERVICES INC	111,164.06	492317	
SETEC FUND			352,825.10**
INDUSTRIAL & COMMERCIAL MECHANICAL	276.00	492267	
WORKER'S COMPENSATION FD			276.00**
MCGRIFF, SEIBELS & WILLIAMS OF TX	227,478.00	492223	
TRISTAR RISK MANAGEMENT	2,680.55	492234	
ARRC CORONAVIRUS RECOVERY			230,158.55**
ELECTRICAL SPECIALTIES, INC.	45.00	492113	
DISTRICT CRT RECORDS TECH			45.00**
CASH ADVANCE ACCOUNT	700.88	492151	
MARINE DIVISION			700.88**
ENTERGY	89.21	492144	
JACK BROOKS REGIONAL AIRPORT	371.07	492150	
AT&T	88.12	492181	
GALLS LLC	1,162.93	492283	
			1,711.33**
			1,866,498.37***



JOINT ELECTION AGREEMENT AND  
ELECTION SERVICES CONTRACT  
BETWEEN JEFFERSON COUNTY  
AND **City of Port Arthur**

This agreement made and entered into, by and between Jefferson County, hereinafter referred to as "County", acting herein by and through its County Judge and Commissioner's Court, joined herein by the **County Election Officer, Laurie Leister, County Clerk, and City of Port Arthur** hereinafter referred to as "Political Subdivision", acting herein by and through its Executive Board.

**WHEREAS**, Political Subdivision is required to conduct an election on **May 7, 2022**;

**THIS JOINT ELECTION AGREEMENT AND ELECTION SERVICES CONTRACT** is made this 15<sup>th</sup> day of February, 2022, by and between the Political Subdivision of **City of Port Arthur**, hereinafter called "Political Subdivision" and Jefferson County, Texas, by its County Judge and joined herein by its County Elections Officer, **Laurie Leister**, hereinafter called "Contracting Officer," pursuant to Texas Election Code Section 31.092. The parties agree to enter into a Joint Election Agreement and an election services contract with each other in accordance with Chapter 271 of the Texas Election Code and this Agreement. This Agreement is entered into in consideration of the mutual covenants and promises hereinafter set out:

1. **RECITALS.** Contracting Officer is the County Clerk of Jefferson County, Texas, and is the County Officer in charge of election duties. Political Subdivision is a political entity situated wholly or partially within Jefferson County, Texas. Political Subdivision and Contracting Officer have determined that it is in the public interest of Jefferson County voters that the following contract be made and entered into for the purpose of having Contracting Officer furnish to Political Subdivision certain election services and equipment needed by Political Subdivision in connection with the holding of its May 7, 2022, Election. Jefferson County's certified Hart InterCivic electronic voting equipment is to be used in this Political Subdivision Election.
2. **DUTIES AND SERVICES OF CONTRACTING OFFICER.** Contracting Officer shall be responsible for performing the following duties and shall furnish the following services and equipment:

(a) Notify and coordinate presiding election judges, alternate judges, and all other election officials appointed by Commissioner's Court to conduct county elections required to administer this Election. Jefferson County will make emergency appointments of election officials if necessary. Compensate all election workers for time worked at the approved hourly rate by Commissioners' Court.

(b) Arrange for poll worker training through a third party or conduct necessary training. Notify

all early voting and Election Day officials of the date, time and place thereof.

(c) Arrange for the use of early voting locations per the attached **Exhibit A – Early Voting Locations** and Election Day polling locations per the attached **Exhibit B – Election Day Vote Centers**. If emergency replacement polling locations are needed, Contracting Officer shall make necessary alternate arrangements to locate another public place (or if unavailable, a private building), and shall notify Political Subdivision as soon as possible.

(d) Procure election kits and supplies and distribute to the precinct judges and early voting deputies. Obtain from the Tax -Assessor /Voter Registrar lists of registered voters to be used in conducting the election in conformity with the boundaries of Political Subdivision and the election precincts established for the election. The Election Day list of registered voters shall be arranged in alphabetical order.

(e) Prepare and test all electronic voting equipment, format ballot styles, secure audio, oversee all equipment and voter registration database programming, assure compliance with equipment security requirements. Arrange for transport of equipment to and from polling locations.

(f) Serve as Early Voting Clerk for this Joint Election and process, print, mail, and tabulate ballots for any eligible voter, who applies for a ballot by mail including all eligible FPCA applicants. Supervise the conduct of early voting in person and appoint sufficient personnel to serve as deputy early voting clerks. Provide lists of early voters as provided by law if requested by Political Subdivision.

(g) Publish legal notice of the date, time and place of the public logic and accuracy test. Prepare test materials and conduct internal election testing, public logic and accuracy test, and tests of tabulation equipment.

(h) Arrange for the early ballot board, signature verification committee, tabulation personnel, and all equipment and supplies needed at central counting station. Tabulate early voting, election night, paper mail ballots and provisional ballots. Tabulate unofficial returns and assist in preparing the tabulation for the official canvass. Provide Political Subdivision its voter history report following the election if requested.

(i) Serve as Custodian of Records for election records in Contracting Officer's custody and provide for the retention of said election records as provided by law.

(j) Provide information services for voters and election officers.

(k) Maintain accurate records of all expenses incurred in connection with the responsibilities under this Agreement and provide Political Subdivision a final invoice after the conduct of the election. Provide any detailed backup to such invoice, if requested, reflecting the charges or components of the costs set forth on the invoice submitted to Political Subdivision.

(l) The Contracting Office is responsible for collecting the compensations sheets for the election judges, clerks, and early voting ballot board. The Contracting Officer will also pay the aforementioned for their services and time in accordance with their rate of pay policy.

(m) Contracting Officer shall conduct a manual count as prescribed by Section 127.201 of the Election Services Contract

Texas Election Code, unless waived by the Secretary of State. A written report shall be submitted to the Secretary of State as required by Section 127.201(E) of the aforementioned Election Code. If requested, Contracting Officer shall provide a written report to Political Subdivision in a timely manner.

(n) The Contracting Officer shall place the funds paid by Political Subdivision hereunder in a "contract fund" as prescribed by Section 31.100 of the Texas Election Code.

**3. DUTIES AND SERVICES OF POLITICAL SUBDIVISION.** Political Subdivision shall be responsible for performing the following duties:

(a) Prepare all election orders, resolutions, notices, and other pertinent documents for adoption and execution by the appropriate Political Subdivision officer or body. Take all actions necessary for calling the Political Subdivision Election which are required by the Texas Election Code and/or the Political Subdivision's governing body, charter, ordinances, or other applicable laws. Execute an Election Services Contract Agreement with Jefferson County Clerk for the purpose of election administration. Serve as Custodian of Records for all election records in its possession as provided by law.

(b) Political Subdivision shall be responsible for the legal sufficiency of any order calling their election. Political Subdivision shall be responsible for all substantive and procedural legal issues governing the conduct of their election. Political Subdivision understands and agrees that Contracting Officer provides no legal advice to Political Subdivision.

(c) Adopt the county voting precincts for this election. Political Subdivision shall adopt the early voting locations used by the county located in the Political Subdivision's jurisdictional boundaries with the stipulation to add additional locations and adopt all early voting dates, and hours recommended by the Contracting Officer in accordance with the Texas Election Code as listed on **Exhibit A – Early Voting Locations**. Political Subdivision shall adopt the Election Day Vote Center polling locations on the attached **Exhibit B – Election Day Vote Centers** for each county voting precinct that is within its jurisdictional boundaries. Political Subdivision shall confirm the accuracy of its jurisdictional boundaries and precincts.

(d) Prepare, post and publish all required election notices for Political Subdivision, except for the Public Test Notice that Contracting Officer shall publish. In addition, if this election's polling locations are different than Political Subdivision's previous election, Political Subdivision shall post notice at the entrance to any previous polling places in its jurisdiction stating that the location has changed and provide the polling location and address for those voters for this election, pursuant to Texas Election Code Section 43.062, unless County has posted the change for their election. Educate the voters in Political Subdivision on early voting times and places and Election Day polling locations.

(e) Political Subdivision shall confirm with Tax-Assessor/Voter Registrar its boundaries, county voting precincts and street details within those boundaries. Political Subdivision will validate all boundaries are defined properly within Jefferson County voter registration database, maps and street lists with block ranges and odd/even/both indicators before the coding and programming of the ballot begins. If changes are necessary after programming has begun, the Political Subdivision responsible will incur the cost of re-programming for all entities involved.

Political Subdivision must proof and approve all programming work done for the jurisdiction according to the attached **Exhibit C- CALENDAR**

(f) Deliver to Contracting Officer, according to the attached **Exhibit C - CALENDAR**, ballot language with Spanish translations, candidate names or measures, the order in which they are to be printed on the ballot with the exact form and spelling. Provide pronunciation for difficult names or words to use on the audio recording. Timely review and sign off on ballot proofs.

(g) Any requests for early voting ballots to be voted by mail received by Political Subdivision must be hand delivered or faxed to Contracting Officer on the day of receipt. If the application is faxed, the original application must be mailed to Contracting Officer. Contracting Officer will process applications, mail appropriate ballots, and tabulate.

(h) If requested, assist Contracting Officer in recruiting bilingual poll workers. Provide documentation on Political Subdivision's efforts to recruit bilingual poll workers if requested by the U. S. Department of Justice.

(i) Pay prorated additional costs incurred by Contracting Officer if a recount for said election is required, the election is contested in any manner, or a runoff is required.

(j) Canvass the returns and declare the election results for Political Subdivision. Political Subdivision is responsible for filing any precinct reports required by the Secretary of State.

(k) The deposit will be waived for this Election Agreement for all Political Subdivisions. All costs will be assessed according to attached schedule on **Exhibit D – Contract Costs** and a detailed billed will be rendered within 30 days after the canvassing of the election or the receipt of all invoices needed to validate the billing. Any discrepancies in billing should be addressed immediately.

(l) Political Subdivision agrees to enter into a Joint Election Agreement with any other political subdivision in Jefferson County which enters into an Election Services Contract with Contracting Officer and which holds an election on **May 7, 2022**.

4. **COST OF SERVICES.** Political Subdivision shall share some expenses for the above services, supplies and equipment. Additional elections may lower costs for each entity, and election cancellations may raise costs for each entity. It is understood that other political entities may wish to participate in the use of the County's electronic voting equipment and polling locations, and it is agreed that Contracting Officer may enter into other contracts with entities for those purposes on terms and conditions generally similar to those set forth in this Agreement. Only the actual expenses directly attributable to this Agreement and any prorated shared expenses may be charged to Political Subdivision, plus a 10% administrative fee.

(a) Costs for early voting, election day, equipment delivery, supplies and mail ballots, including payroll and equipment leasing, will be shared proportionally between all political subdivisions which enter into a joint election agreement with County according to the number of voting precincts within each political subdivision. Equipment leasing costs are listed on **Exhibit D – Contract Costs**.

- (b) Costs for ballot programming will be paid by each political subdivision for the number of election contests each has on the ballot according to costs as listed on **Exhibit D - Contract Costs**.

## 5. GENERAL CONDITIONS.

(a) The parties agree that the timing is critical on all duties in this Agreement. Lack of adherence to any deadline in the CALENDAR without prior agreement of Contracting Officer may result in cancellation of Contracting Officer's duties and obligations to conduct Political Subdivision's election under this Agreement or, at the discretion of Contracting Officer, a late penalty surcharge in an amount not to exceed 10% of the final election cost. Adherence to the CALENDAR is critical because of Jefferson County's obligation to complete all programming and testing and to process, print and mail military and overseas ballots by state/federal deadlines and our duty to conduct federal, state, county elections and/or other contracted elections.

(b) In accordance with Section 31.098 of the Texas Election Code, Contracting Officer is authorized to contract with third persons for election services and supplies and is authorized to hire necessary temporary personnel to perform contracted duties. Part-time personnel will be compensated at the hourly rate set by Jefferson County.

(c) Political Subdivision acknowledges that electronic voting equipment is highly technical and it is conceivable that, despite the best effort of the parties and technical assistance, it might fail during the election. Contracting Officer will do whatever is possible to remedy the situation, but Political Subdivision agrees that should such equipment fail, it will not make any claim for damages of any kind.

(d) Any qualified voter in the Joint Election may vote early by personal appearance at any of the joint early voting locations or at any Vote Center/Polling Location on Election Day.

(e) Jefferson County Elections Department may contract with numerous political entities for the Joint Election, and the parties agree that all ballot styles will be programmed into one electronic voting system. Each voter will receive one ballot which contains all races and issues in the Joint Election for which the voter is eligible at the address and in the precinct in which the voter is currently registered. One joint voter sign in process consisting of a common list of registered voters and common signature rosters shall be used in precincts in which the county polling locations are used.

(f) The Contracting Officer shall file copies of this Agreement with the Auditor and Treasurer of Jefferson County not later than the 10<sup>th</sup> day from receipt of the fully executed contract by Contracting Officer.

(g) Jefferson County is self-insured for personal liability issues. Should Political Subdivision desire insurance for injuries during this election or other liabilities, entity shall make such arrangements separate from this Agreement.

(h) In the event that the performance by Contracting Officer of any of its obligations hereunder



shall be interrupted or delayed by any occurrence not occasioned by its own conduct, whether such occurrence be an act of God or the result of war, riot, civil commotion, sovereign conduct, or the act or condition of any persons not a party thereof, then it shall be excused from such performance for such period of time as is reasonably necessary after such occurrence to remedy the effects thereof.

(i) The parties to this Agreement agree that Political Subdivision may cancel this Agreement in the event that it has no need to conduct an election by 60<sup>th</sup> day before Election Day. If Political Subdivision's election is cancelled after deadline, a \$200 contract preparation and processing fee will be due in addition to any costs incurred by Contracting Officer on behalf of Political Subdivision prior to said cancellation.

(j) The Political Subdivision has the option of extending the terms of this Agreement through its runoff election, if applicable. Political Subdivision may reduce the number of the adopted early voting locations and/or Election Day voting locations in which precincts are not involved in a runoff election. In the event of a runoff which Political Subdivision wants Contracting Officer to conduct, Political Subdivision agrees to attempt to coordinate the date with other entities participating in this Joint Election. If Political Subdivision elects to have Contracting Officer conduct a runoff election, the cost will be determined by the number of entities participating and the actual costs plus administrative fees. Political Subdivision will be responsible for all orders, notices, and publications required for their runoff except the publication of the public logic and accuracy test which Contracting Officer will publish.

## **6. DISPUTE RESOLUTION PROCEDURE**

The parties agree to use dispute resolution process provided for in Chapter 2260 of the Texas Government Code to attempt to resolve all disputes arising under this Agreement. Either party must give written notice to the other party of a claim for breach of this Agreement not later than the 180<sup>th</sup> day after the date of the event, giving rise to the claim. By their execution of their Agreement, the parties acknowledge and knowingly and voluntarily agree that neither the execution of this Agreement; nor the conduct, act or inaction by any person in the execution, administration, or performance of this Agreement constitutes or is intended to constitute a waiver of the party's immunity from suit with respect to claims of third parties.

## **7. ENTIRE AGREEMENT/AMENDMENT**

This Agreement constitutes the entire agreement between City of Port Arthur and Contracting Officer. This Agreement may be amended only in writing and signed by the parties.

## **8. NOTICES**

Except as otherwise provided in this section, all notices, consents, approvals, demands, requests, or other communications provided for or permitted to be given under any of the provisions of this Agreement shall be in writing and shall be deemed to have duly given or served when delivered by hand delivery or when deposited in the U.S. mail by registered or certified mail, return receipt requested, postage prepaid, and addressed as set forth below or to such other person or address as may be given in writing by either party to the other in accordance with this section:

**City of Port Arthur:** City of Port Arthur  
Ronald Burton  
City Manager  
P.O. Box 1089  
Port Arthur, TX 77641

**JEFFERSON COUNTY:** Laurie Leister, County Clerk  
P. O. Box 1151  
Beaumont, TX 77704

**IN WITNESS WHEREOF**, each of the parties agrees to the terms of this Agreement and has caused this Agreement to be executed on the 24<sup>th</sup> day of January, 2022.

**City of Port Arthur**

By:   
Name: Ronald Burton  
Title: City Manager



Attest: 

**IN WITNESS WHEREOF**, each of the parties agrees to the terms of this Agreement and has caused this Agreement to be executed on the 15<sup>th</sup> day of February, 2022.

**Jefferson County, Texas**

By:   
Name: Jeff Branick  
Title: County Judge



By:   
Name: Laurie Leister  
Title: County Clerk

Attest: 

## EXHIBIT A

**NOTICE OF EARLY VOTING LOCATIONS AND HOURS FOR**  
**May 7, 2022, CONSTITUTIONAL AMENDMENT AND JOINT ELECTION**  
**(Aviso de localizaciones y horas para elecciones adelantadas de Mayo 7, 2022**  
**Sobre Enmiendas A La Constitución y Conjunta)**

Early Voting by personal appearance will be conducted at the following dates and times:  
*(La votación adelantada en persona se llevará a en las siguientes fechas y horarios:)*

**EARLY VOTING LOCATIONS:**

(Localizaciones de Votación Adelantada):

Beaumont Courthouse-Main location	1085 Pearl St., ( <i>Lobby</i> ), Beaumont, TX
Port Arthur Sub-Courthouse	525 Lakeshore Dr. ( <i>Foyer</i> ), Port Arthur, TX
Rogers Park Recreation Center	6540 Gladys, Beaumont, TX
Port Arthur Library	4615 9th Ave., ( <i>Lucy Stiefel Gallery</i> ), Port Arthur, TX
Theodore Johns Library	4255 Fannett Rd., ( <i>Meeting Room</i> ), Beaumont, TX
John Paul Davis Community Center	3580 E. Lucas, Beaumont, TX
Marion & Ed Hughes Public Library	2712 Nederland Ave., ( <i>Meeting Room</i> ), Nederland, TX
Groves Activity Building	6150 39th Street, ( <i>Lounge</i> ), Groves, TX
Effie & Wilton Hebert Library	2025 Merriman St., ( <i>Community Room</i> ), Port Neches, TX
Ray Chesson Office Building	19217 FM 365, ( <i>Courtroom</i> ), Beaumont, TX
Precinct One Service Center	20215 W. Hwy. 90, ( <i>Front Conference Room</i> ), China, TX

**DATES AND HOURS FOR ALL ABOVE LOCATIONS:**

(Fechas y Horas para todas las localizaciones anteriores):

April 25 - 29 ( <i>Abril 25 - 29</i> )	Monday - Friday ( <i>Lunes - Viernes</i> )	8:00 a.m. - 5:00 p.m.
April 30 ( <i>Abril 30</i> )	Saturday ( <i>Sábado</i> )	8:00 a.m. - 5:00 p.m.
May 1 ( <i>Mayo 1</i> )	Sunday ( <i>Domingo</i> )	12:00 p.m. - 6:00 p.m.
May 2 - 3 ( <i>Mayo 2- Mayo 3</i> )	Monday - Tuesday ( <i>Lunes - Martes</i> )	7:00 a.m. - 7:00 p.m.

**EXHIBIT B - ELECTION DAY VOTE CENTERS**

<b>precincts Voting at Location</b>	<b>Election Day Polling Places (Localizaciones)</b>	<b>ADDRESS (Dirección)</b>	<b>City, State, Zip code (Ciudad, Estado, Código postal)</b>
<b>precintos de votación en el Localización)</b>			
L (todos)	Amelia Elementary School ( <i>Gymnasium</i> )	565 S. Major Dr	Beaumont, TX 77707
L (todos)	Beaumont Municipal Airport ( <i>Conference Room</i> )	455 Keith Rd.	Beaumont, TX 77713
L (todos)	Bevil Oaks City Hall	13560 River Oaks Blvd.	Bevil Oaks, TX 77713
L (todos)	BISD Administration Building ( <i>Boardroom</i> )	3395 Harrison Ave.	Beaumont, TX 77706
L (todos)	Dishman Elementary ( <i>Gymnasium</i> )	3475 Champions Dr.	Beaumont, TX 77707
L (todos)	O.C. Mike Taylor Career Center ( <i>First Floor Old Library</i> )	2330 North St.	Beaumont, TX 77702
L (todos)	Precinct 1 Service Center ( <i>Front Conference Room</i> )	2020S W. Hwy. 90	China, TX 77613
L (todos)	Rogers Park Community Center	6540 Gladys Ave.	Beaumont, TX 77706
L (todos)	Roy Guess Elementary ( <i>Hallway near Gymnasium</i> )	8055 Voth Rd.	Beaumont, TX 77708
L (todos)	Hebert Library ( <i>Community Room</i> )	2025 Merriman St.	Port Neches, TX 77651
L (todos)	Jefferson County WCID 10 Fire Station ( <i>Front Lobby</i> )	2024 Spurlock Rd.	Nederland, TX 77627
L (todos)	Groves Public Library ( <i>Front Meeting Room</i> )	5600 West Washington	Groves, TX 77619
L (todos)	Jerry Ware Airport Terminal ( <i>Conference Room off Main Lobby</i> )	5000 Jerry Ware Dr.	Beaumont, TX 77705
L (todos)	Ray Chesson Office Building ( <i>Courtroom</i> )	19217 FM 365	Beaumont, TX 77705
L (todos)	Jefferson County ESD #4 ( <i>Main Meeting Room</i> )	12880 FM 365	Beaumont, TX 77705
L (todos)	Marion & Ed Hughes Public Library ( <i>Meeting Room</i> )	2712 Nederland Ave.	Nederland, TX 77627
L (todos)	Port Neches City Hall ( <i>Council Chambers - Room 104</i> )	1005 Merriman	Port Neches, TX 77651
L (todos)	Groves Activity Building ( <i>Lounge</i> )	6150 39th Street.	Groves, TX 77619
L (todos)	DeQueen Elementary ( <i>Fifth Grade Hall</i> )	740 DeQueen Blvd.	Port Arthur, TX 77640
L (todos)	Zion Hill Baptist Church ( <i>Education Building</i> )	5848 Roosevelt Ave.	Port Arthur, TX 77640
L (todos)	Jefferson County Sub-Courthouse ( <i>Foyer</i> )	525 Lakeshore Dr.	Port Arthur, TX 77640
L (todos)	Former Dowling Elementary Campus ( <i>Library</i> )	6301 Pat Ave	Port Arthur, TX 77640
L (todos)	O.W. Collins Retirement Center ( <i>Social Service Room</i> )	4440 Gulfway Dr.	Port Arthur, TX 77642
L (todos)	Port Arthur Library ( <i>Lucy Stiefel Gallery</i> )	4615 9th Ave	Port Arthur, TX 77642
L (todos)	Queen of Vietnam Catholic Church ( <i>St. Joseph Hall</i> )	801 9th Ave	Port Arthur, TX 77642
L (todos)	R.L. Gabby Eldridge Center	5262 S. Gulfway Dr	Sabine Pass, TX 77655
L (todos)	Travis Elementary ( <i>Library</i> )	1115 Lakeview Ave.	Port Arthur, TX 77642
L (todos)	Willie Ryman Community Center	3248 39th Street	Port Arthur, TX 77642
L (todos)	Alice Keith Park Recreation Center	4075 Highland Ave.	Beaumont, TX 77705
L (todos)	Charlton-Pollard Elementary ( <i>Gymnasium</i> )	825 Jackson St.	Beaumont, TX 77701
L (todos)	Lamar University Montagne Center, ( <i>Cardinal Club Room</i> )	4401 S. MLK PKWY	Beaumont, TX 77705
L (todos)	Hamshire VFD and Community Center	12318 2nd St.	Hamshire, TX 77622
L (todos)	Jefferson County Courthouse ( <i>Lobby</i> )	1085 Pearl St.	Beaumont, TX 77701
L (todos)	MLK Middle School ( <i>Gymnasium</i> )	1400 Avenue A	Beaumont, TX 77701
L (todos)	John Paul Davis Community Center	3580 E. Lucas Dr.	Beaumont, TX 77703
L (todos)	Precinct 4 Service Center ( <i>Conference Room</i> )	7780 Boyt Rd.	Beaumont, TX 77713
L (todos)	Sterling Pruitt Center ( <i>Multi-purpose Room</i> )	2930 Gulf St.	Beaumont, TX 77703
L (todos)	Theodore Johns Library ( <i>Meeting Room</i> )	4255 Fannett Rd.	Beaumont, TX 77705

Denotes Change

**EXHIBIT C**  
**CALENDAR**

The Political Subdivision agrees that timing is critical, and lack of adherence to this CALENDAR without prior agreement of Contracting Officer may result in additional charges or cancellation of Contracting Officer's duties and obligations to conduct Political Subdivision's election under this Contract.

**School Districts must adhere to all deadlines, even if on Spring Break.**

Please refer to the Texas Secretary of State's website for a complete calendar of events including citations to the Texas Election Code and for information specific to entity type. Confer with your attorney on any statutes that govern your entity. Please comply with all orders, postings and notices as required for your Political Subdivision. Contracting Officer will provide the publication of one Notice of Public Test in English and Spanish.

**March 7, 2022**

Prior to September 1, 2021, each Political Subdivision is responsible for validating with the Voter Registrar that the boundaries for their voting precincts are correct and supplying the Contracting Officer with a map of such boundaries.

**68<sup>th</sup> day before Election Day**

Recommended date to conduct ballot position drawing.

Notice of ballot position drawing must be posted for 72 hours immediately preceding time of drawing.

**\*\*Please schedule ballot drawing as soon as possible and email the BALLOT FORMAT AND ORDER OF CANDIDATES ON BALLOT to Contracting Officer at [countyclerk@co.jefferson.tx.us](mailto:countyclerk@co.jefferson.tx.us).\*\***

**60th day before Election Day**

Last day for the governing body of a political subdivision to deliver notice of the election to the county clerk/elections administrator and voter registrar of each county in which the political subdivision is wholly or partly located. (Sec. 4.008).

Deadline to notify Contracting Officer via email of the following items:

- whether or not Political Subdivision has a **contested election**.
- **candidate names**, including **write-in candidates**.
- any **candidate withdrawals** or **election cancellation**.
- **order of candidates on ballot**. (We prefer to receive it sooner if it is available.)
- **Spanish translations** of all ballot titles, contests, and ballot language.

- **phonetic pronunciations** of all candidate names which will be used for the ballot audio recording.

### **60th day before Election Day - Continued**

Deadline to **cancel election** and incur **no fees** under the Election Services Agreement.

Deadline to receive executed **Election Services Agreement** by mail, personal delivery, or email.

Deadline to receive copy of **Order of Election**.

Contracting Officer contact information:

Email: [countyclerk@co.jefferson.tx.us](mailto:countyclerk@co.jefferson.tx.us)

Mail: P. O. Box 1151, Beaumont, TX 77704-1151

Hand Delivery: 1085 Pearl Street, First Floor, Beaumont, Texas 77701

If additional time is needed because of meeting schedules, please notify us.

**\*\*Deadlines for ballot proofing and ballot approval will be emailed with ballot proofs. The parties must adhere to deadlines of 24 hour turnaround time, even if they occur during Spring Break, in order for our office to meet the State and Federal deadlines to mail military and overseas ballots.\*\***

### **45th day before Election Day**

Deadline to mail ballots to military or overseas voters who submitted their ballot request via a federal postcard application (FPCA) or via a standard application for ballot by mail and indicated that they are outside the United States. Ballots must be mailed by this date or the 7th day after the clerk receives the application. If the early voting clerk cannot meet this 45th-day deadline, the clerk must notify the Secretary of State within 24 hours. (Sec. 86.004(b)).

### **30th day before Election Day**

Last day to register to vote or make a change of address effective for the election. (Secs. 13.143, 15.025).

First day of period during which notice of election must be published if the method of giving notice is **not** specified by a law outside the Election Code, and **publication** is the selected method of giving notice. (Sec. 4.003(a)(1)). The notice of election ordered by an authority of a city or school district, must be given by publication in a newspaper in addition to any other method specified. (Secs. 4.003(c) and (d)).

### **21st day before Election Day**

Last day to post notice of election on bulletin board used for posting notices of meetings of governing body. (Sec. 4.003(b)). A [Record of Posting Notice of Election \(PDF\)](#) should be completed at the time of posting. (Sec. 4.005).

### **12th day before Election Day**

First day to vote early in person. (Sec. 85.001(a)).

**NOTE - Political Subdivisions Other than Cities and Counties:** Early voting in person must be conducted at least eight (8) hours each weekday that is not a legal state holiday unless the political subdivision has fewer than 1,000 registered voters, in which case early voting in person must be conducted at least three (3) hours per day. (Sec. 85.005(b)).

**NOTE - Cities and counties:** Early voting in person must be conducted on the weekdays of the early voting period and during the hours that the county clerk's or city secretary's main business office is regularly open for business. (Sec. 85.005(a)). However, because cities and counties must have office hours for election-related business at least three (3) hours every business day for this type of election, we harmonize these requirements with the result that, if a city or county is not regularly open for business on one or more weekdays, on those "closed" days, a city or county must conduct early voting for at least three (3) hours a day at the main early voting location (except for a city's two 12-hour days, when it must be open for the full 12 hours).

**NOTE - Cities:** Cities must choose two (2) weekdays for the main early voting polling place location to be open for 12 hours during the regular early voting period. City council must choose the two weekdays. (Sec. 85.005(d)).

**NOTE - Independent School Districts:** Despite the change in state law that allows an ISD to be closed on school holidays during the mandatory office hours period, you are **required** to be open during the entire early voting period, except on legal state and national holidays.

**NOTE - Joint Elections:** If entities are conducting early voting by personal appearance jointly, we *recommend* a unified schedule covering all requirements; i.e., no entity's requirements should be neglected or subtracted as a result of a joint agreement.

### **10th day before Election Day**

Last day of period during which notice of election must be published if method of giving notice is not specified by a law outside the Election Code and publication is the selected method of giving notice. (Sec. 4.003(a)(1)). The notice of election ordered by a commissioners court or by an authority of a city or school district, must be given by publication in a newspaper in addition to any other method specified. (Secs. 4.003(c) and (d)).

Last day to mail a copy of the notice of election to each registered voter in the county if method of giving notice is not specified by a law outside the Election Code and this method of giving notice is selected. (Secs. 1.006, 4.003(a)(3)).

**Cities and Counties – Weekend Early Voting Hours - Notice Requirement:** Last day to post notice on bulletin board used for posting notice of city council or commissioners court, if early voting will be conducted on Saturday (Sec. 85.007). Notice must be posted at least 72 hours before early voting begins on a Saturday or Sunday. Notice must also be posted to the political subdivision's website, if one is maintained.

**NOTE - NEW LAW:** Section 85.007, as amended by House Bill 2721 (2015), requires that the election notice, which includes the days and hours of early voting be posted on the political subdivision's website, if the political subdivision maintains a website.

**4th day before Election Day**

Last day to vote early by personal appearance. (Sec. 85.001(a)).

**Election Day**

Polls open 7:00 A.M. – 7:00 P.M.

**30 days from date of final invoice**

Pay balance due for election services. Please make checks payable to:

Jefferson County Treasurer  
P O Box 1151,  
Beaumont, Texas 77704-1151



## EXHIBIT D

## CONTRACT COSTS

Voting Equipment	
Judge's Booth Controller	\$330.00
eSlate	\$330.00
Disable Access Unit (DAU)	\$396.00
Privacy Booth	\$20.00
Ballot Box	\$5.00
Communication Devices	
EA Tablet + WIFI	\$119.50
Cell Phone	\$30.00
Mandatory Signs	
Large A-Frame (ID Required )	\$10.00
Large A-Frame (Notices )	\$10.00
PROGRAMMING	COUNTY COST
1 - 5 RACES	\$1,125.00
6 - 10 RACES	\$1,898.00
11-20 RACES	\$2,475.00
21-40 RACES	\$3,135.00
41-75 RACES	\$3,960.00
76-100 RACES	\$4,704.00
BALLOT PRINTING	COUNTY COST
8.5 X 11	\$0.23
8.5 X 14	\$0.25
8.5 X 17	\$0.28
Sample Ballots	\$0.06
SUPPLIES	
ELECTION KITS / w Seals EV & ED	\$40.00
Mail Ballots (Per Set)	\$0.75
Supply Bag Consumables (per location)	\$20.00

REVISED 07/19/16



JOINT ELECTION AGREEMENT AND  
ELECTION SERVICES CONTRACT  
BETWEEN JEFFERSON COUNTY  
AND **Port Arthur Independent School District**

This agreement made and entered into, by and between Jefferson County, hereinafter referred to as "County", acting herein by and through its County Judge and Commissioner's Court, joined herein by the **County Election Officer, Laurie Leister, County Clerk, and Port Arthur Independent School District** hereinafter referred to as "Political Subdivision", acting herein by and through its Executive Board.

**WHEREAS**, Political Subdivision is required to conduct an election on **May 7, 2022**;

**THIS JOINT ELECTION AGREEMENT AND ELECTION SERVICES CONTRACT** is made this 15th day of February, 2022, by and between the Political Subdivision of **Port Arthur Independent School District**, hereinafter called "Political Subdivision" and Jefferson County, Texas, by its County Judge and joined herein by its County Elections Officer, **Laurie Leister**, hereinafter called "Contracting Officer," pursuant to Texas Election Code Section 31.92. The parties agree to enter into a Joint Election Agreement and an election services contract with each other in accordance with Chapter 271 of the Texas Election Code and this Agreement. This Agreement is entered into in consideration of the mutual covenants and promises hereinafter set out:

1. **RECITALS.** Contracting Officer is the County Clerk of Jefferson County, Texas, and is the County Officer in charge of election duties. Political Subdivision is a political entity situated wholly or partially within Jefferson County, Texas. Political Subdivision and Contracting Officer have determined that it is in the public interest of Jefferson County voters that the following contract be made and entered into for the purpose of having Contracting Officer furnish to Political Subdivision certain election services and equipment needed by Political Subdivision in connection with the holding of its May 7, 2022, Election. Jefferson County's certified Hart InterCivic electronic voting equipment is to be used in this Political Subdivision Election.
2. **DUTIES AND SERVICES OF CONTRACTING OFFICER.** Contracting Officer shall be responsible for performing the following duties and shall furnish the following services and equipment:

(a) Notify and coordinate presiding election judges, alternate judges, and all other election officials appointed by Commissioner's Court to conduct county elections required to administer this Election. Jefferson County will make emergency appointments of election officials if necessary. Compensate all election workers for time worked at the approved hourly rate by Commissioners' Court.

(b) Arrange for poll worker training through a third party or conduct necessary training. Notify all early voting and Election Day officials of the date, time and place thereof.

(c) Arrange for the use of early voting locations per the attached **Exhibit A – Early Voting Locations** and Election Day polling locations per the attached **Exhibit B – Election Day Vote Centers**. If emergency replacement polling locations are needed, Contracting Officer shall make necessary alternate arrangements to locate another public place (or if unavailable, a private building), and shall notify Political Subdivision as soon as possible.

(d) Procure election kits and supplies and distribute to the precinct judges and early voting deputies. Obtain from the Tax -Assessor /Voter Registrar lists of registered voters to be used in conducting the election in conformity with the boundaries of Political Subdivision and the election precincts established for the election. The Election Day list of registered voters shall be arranged in alphabetical order.

(e) Prepare and test all electronic voting equipment, format ballot styles, secure audio, oversee all equipment and voter registration database programming, assure compliance with equipment security requirements. Arrange for transport of equipment to and from polling locations.

(f) Serve as Early Voting Clerk for this Joint Election and process, print, mail, and tabulate ballots for any eligible voter, who applies for a ballot by mail including all eligible FPCA applicants. Supervise the conduct of early voting in person and appoint sufficient personnel to serve as deputy early voting clerks. Provide lists of early voters as provided by law if requested by Political Subdivision.

(g) Publish legal notice of the date, time and place of the public logic and accuracy test. Prepare test materials and conduct internal election testing, public logic and accuracy test, and tests of tabulation equipment.

(h) Arrange for the early ballot board, signature verification committee, tabulation personnel, and all equipment and supplies needed at central counting station. Tabulate early voting, election night, paper mail ballots and provisional ballots. Tabulate unofficial returns and assist in preparing the tabulation for the official canvass. Provide Political Subdivision its voter history report following the election if requested.

(i) Serve as Custodian of Records for election records in Contracting Officer's custody and provide for the retention of said election records as provided by law.

(j) Provide information services for voters and election officers.

(k) Maintain accurate records of all expenses incurred in connection with the responsibilities under this Agreement and provide Political Subdivision a final invoice after the conduct of the election. Provide any detailed backup to such invoice, if requested, reflecting the charges or components of the costs set forth on the invoice submitted to Political Subdivision.

(l) The Contracting Office is responsible for collecting the compensations sheets for the election judges, clerks, and early voting ballot board. The Contracting Officer will also pay the

aforementioned for their services and time in accordance with their rate of pay policy.

(m) Contracting Officer shall conduct a manual count as prescribed by Section 127.201 of the Texas Election Code, unless waived by the Secretary of State. A written report shall be submitted to the Secretary of State as required by Section 127.201(E) of the aforementioned Election Code. If requested, Contracting Officer shall provide a written report to Political Subdivision in a timely manner.

(n) The Contracting Officer shall place the funds paid by Political Subdivision hereunder in a "contract fund" as prescribed by Section 31.100 of the Texas Election Code.

**3. DUTIES AND SERVICES OF POLITICAL SUBDIVISION.** Political Subdivision shall be responsible for performing the following duties:

(a) Prepare all election orders, resolutions, notices, and other pertinent documents for adoption and execution by the appropriate Political Subdivision officer or body. Take all actions necessary for calling the Political Subdivision Election which are required by the Texas Election Code and/or the Political Subdivision's governing body, charter, ordinances, or other applicable laws. Execute an Election Services Contract Agreement with Jefferson County Clerk for the purpose of election administration. Serve as Custodian of Records for all election records in its possession as provided by law.

(b) Political Subdivision shall be responsible for the legal sufficiency of any order calling their election. Political Subdivision shall be responsible for all substantive and procedural legal issues governing the conduct of their election. Political Subdivision understands and agrees that Contracting Officer provides no legal advice to Political Subdivision.

(c) Adopt the county voting precincts for this election. Political Subdivision shall adopt the early voting locations used by the county located in the Political Subdivision's jurisdictional boundaries with the stipulation to add additional locations and adopt all early voting dates, and hours recommended by the Contracting Officer in accordance with the Texas Election Code as listed on Exhibit A – Early Voting Locations. Political Subdivision shall adopt the Election Day Vote Center polling locations on the attached Exhibit B – Election Day Vote Centers for each county voting precinct that is within its jurisdictional boundaries. Political Subdivision shall confirm the accuracy of its jurisdictional boundaries and precincts.

(d) Prepare, post and publish all required election notices for Political Subdivision except for the Public Test Notice that Contracting Officer shall publish. In addition, if this election's polling locations are different than Political Subdivision's previous election, Political Subdivision shall post notice at the entrance to any previous polling places in its jurisdiction stating that the location has changed and provide the polling location and address for those voters for this election, pursuant to Texas Election Code Section 43.062, unless County has posted the change for their election. Educate the voters in Political Subdivision on early voting times and places and Election Day polling locations.

(e) Political Subdivision shall confirm with Tax-Assessor/Voter Registrar its boundaries, county voting precincts and street details within those boundaries. Political Subdivision will validate all boundaries are defined properly within Jefferson County voter registration database, maps and street lists with block ranges and odd/even/both indicators before the coding and

programming of the ballot begins. If changes are necessary after programming has begun, the Political Subdivision responsible will incur the cost of re-programming for all entities involved. Political Subdivision must proof and approve all programming work done for the jurisdiction according to the attached **Exhibit C- CALENDAR**

(f) Deliver to Contracting Officer, according to the attached **Exhibit C - CALENDAR**, ballot language with Spanish translations, candidate names or measures, the order in which they are to be printed on the ballot with the exact form and spelling. Provide pronunciation for difficult names or words to use on the audio recording. Timely review and sign off on ballot proofs.

(g) Any requests for early voting ballots to be voted by mail received by Political Subdivision must be hand delivered or faxed to Contracting Officer on the day of receipt. If the application is faxed, the original application must be mailed to Contracting Officer. Contracting Officer will process applications, mail appropriate ballots, and tabulate.

(h) If requested, assist Contracting Officer in recruiting bilingual poll workers. Provide documentation on Political Subdivision's efforts to recruit bilingual poll workers if requested by the U. S. Department of Justice.

(i) Pay prorated additional costs incurred by Contracting Officer if a recount for said election is required, the election is contested in any manner, or a runoff is required.

(j) Canvass the returns and declare the election results for Political Subdivision. Political Subdivision is responsible for filing any precinct reports required by the Secretary of State.

(k) The deposit will be waived for this Election Agreement for all Political Subdivisions. All costs will be assessed according to attached schedule on **Exhibit D – Contract Costs** and a detailed billed will be rendered within 30 days after the canvassing of the election or the receipt of all invoices needed to validate the billing. Any discrepancies in billing should be addressed immediately.

(l) Political Subdivision agrees to enter into a Joint Election Agreement with any other political subdivision in Jefferson County which enters into an Election Services Contract with Contracting Officer and which holds an election on **May 7, 2022**.

4. **COST OF SERVICES.** Political Subdivision shall share some expenses for the above services, supplies and equipment. Additional elections may lower costs for each entity, and election cancellations may raise costs for each entity. It is understood that other political entities may wish to participate in the use of the County's electronic voting equipment and polling locations, and it is agreed that Contracting Officer may enter into other contracts with entities for those purposes on terms and conditions generally similar to those set forth in this Agreement. Only the actual expenses directly attributable to this Agreement and any prorated shared expenses may be charged to Political Subdivision, plus a 10% administrative fee.

(a) Costs for early voting, election day, equipment delivery, supplies and mail ballots, including payroll and equipment leasing, will be shared proportionally between all political subdivisions which enter into a joint election agreement with County according

to the number of voting precincts within each political subdivision. Equipment leasing costs are listed on **Exhibit D – Contract Costs.**

- (b) Costs for ballot programming will be paid by each political subdivision for the number of election contests each has on the ballot according to costs as listed on **Exhibit D - Contract Costs.**

## 5. GENERAL CONDITIONS.

- (a) The parties agree that the timing is critical on all duties in this Agreement. Lack of adherence to any deadline in the CALENDAR without prior agreement of Contracting Officer may result in cancellation of Contracting Officer's duties and obligations to conduct Political Subdivision's election under this Agreement or, at the discretion of Contracting Officer, a late penalty surcharge in an amount not to exceed 10% of the final election cost. Adherence to the CALENDAR is critical because of Jefferson County's obligation to complete all programming and testing and to process, print and mail military and overseas ballots by state/federal deadlines and our duty to conduct federal, state, county elections and/or other contracted elections.
- (b) In accordance with Section 31.098 of the Texas Election Code, Contracting Officer is authorized to contract with third persons for election services and supplies and is authorized to hire necessary temporary personnel to perform contracted duties. Part-time personnel will be compensated at the hourly rate set by Jefferson County.
- (c) Political Subdivision acknowledges that electronic voting equipment is highly technical and it is conceivable that, despite the best effort of the parties and technical assistance, it might fail during the election. Contracting Officer will do whatever is possible to remedy the situation, but Political Subdivision agrees that should such equipment fail, it will not make any claim for damages of any kind.
- (d) Any qualified voter in the Joint Election may vote early by personal appearance at any of the joint early voting locations or at any Vote Center/Polling Location on Election Day.
- (e) Jefferson County Elections Department may contract with numerous political entities for the Joint Election, and the parties agree that all ballot styles will be programmed into one electronic voting system. Each voter will receive one ballot which contains all races and issues in the Joint Election for which the voter is eligible at the address and in the precinct in which the voter is currently registered. One joint voter sign in process consisting of a common list of registered voters and common signature rosters shall be used in precincts in which the county polling locations are used.
- (f) The Contracting Officer shall file copies of this Agreement with the Auditor and Treasurer Jefferson County not later than the 10 day from receipt of the fully executed contract Contracting Officer.
- (g) Jefferson County is self-insured for personal liability issues. Should Political

Subdivision desire insurance for injuries during this election or other liabilities, entity shall make such arrangements separate from this Agreement.

- (h) In the event that the performance by Contracting Officer of any of its obligations hereunder shall be interrupted or delayed by any occurrence not occasioned by its own conduct, whether such occurrence be an act of God or the result of war, riot, civil commotion, sovereign conduct, or the act or condition of any persons not a party thereof, then it shall be excused from such performance for such period of time as is reasonably necessary after such occurrence to remedy the effects thereof.
- (i) The parties to this Agreement agree that Political Subdivision may cancel this Agreement in the event that it has no need to conduct an election by 60<sup>th</sup> day before Election Day. If Political Subdivision's election is cancelled after deadline, a \$200 contract preparation and processing fee will be due in addition to any costs incurred by Contracting Officer on behalf of Political Subdivision prior to said cancellation.
- (j) The Political Subdivision has the option of extending the terms of this Agreement through its runoff election, if applicable. Political Subdivision may reduce the number of the adopted early voting locations and/or Election Day voting locations in which precincts are not involved in a runoff election. In the event of a runoff which Political Subdivision wants Contracting Officer to conduct, Political Subdivision agrees to attempt to coordinate the date with other entities participating in this Joint Election. If Political Subdivision elects to have Contracting Officer conduct a runoff election, the cost will be determined by the number of entities participating and the actual costs plus administrative fees. Political Subdivision will be responsible for all orders, notices, and publications required for their runoff except the publication of the public logic and accuracy test which Contracting Officer will publish.

## **6. DISPUTE RESOLUTION PROCEDURE**

The parties agree to use dispute resolution process provided for in Chapter 2260 of the Texas Government Code to attempt to resolve all disputes arising under this Agreement. Either party must give written notice to the other party of a claim for breach of this Agreement not later than the 180<sup>th</sup> day after the date of the event, giving rise to the claim. By their execution of their Agreement, the parties acknowledge and knowingly and voluntarily agree that neither the execution of this Agreement; nor the conduct, act or inaction by any person in the execution, administration, or performance of this Agreement constitutes or is intended to constitute a waiver of the party's immunity from suit with respect to claims of third parties.

## **7. ENTIRE AGREEMENT/AMENDMENT**

This Agreement constitutes the entire agreement between Port Arthur Independent School District and Contracting Officer. This Agreement may be amended only in writing and signed by the parties.



**8. NOTICES**

Except as otherwise provided in this section, all notices, consents, approvals, demands, request, or other communications provided for or permitted to be given under any of the provisions of this Agreement shall be in writing and shall be deemed to have duly given or served when delivered by hand delivery or when deposited in the U.S. mail by registered or certified mail, return receipt requested, postage prepaid, and addressed as set forth below or to such other person or address as may be given in writing by either party to the other in accordance with this section:

**Port Arthur Independent School District:** Port Arthur Independent School District

Dr. Mark Porterie  
Superintendent  
4801 9th Ave.  
Port Arthur, TX 77642

**JEFFERSON COUNTY:** Laurie Leister, County Clerk  
P. O. Box 1151  
Beaumont, TX 77704

**IN WITNESS WHEREOF**, each of the parties agrees to the terms of this Agreement and has caused this Agreement to be executed on the 4<sup>th</sup> day of February, 2022.

**Port Arthur Independent School District**

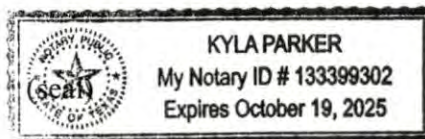

By: Dr. Mark Porterie  
Name: Dr. Mark Porterie  
Title: Superintendent

Attest: Kyle Parker

**IN WITNESS WHEREOF**, each of the parties agrees to the terms of this Agreement and has caused this Agreement to be executed on the 15<sup>th</sup> day of February, 2020.

**Jefferson County, Texas**

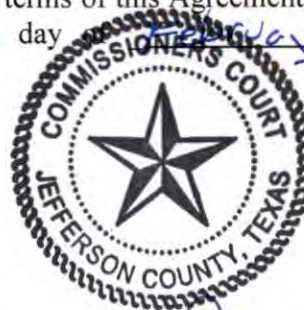

By: [Signature]  
Name: Jeff Branick  
Title: County Judge

(seal)

By: Laurie Leister  
Name: Laurie Leister  
Title: County Clerk

Attest: [Signature]

## EXHIBIT A

**NOTICE OF EARLY VOTING LOCATIONS AND HOURS FOR**  
**May 7, 2022, CONSTITUTIONAL AMENDMENT AND JOINT ELECTION**  
**(Aviso de localizaciones y horas para elecciones adelantadas de Mayo 7, 2022**  
**Sobre En miendas A La Constitución y Conjunta)**

Early Voting by personal appearance will be conducted at the following dates and times:  
*(La votación adelantada en persona se llevará a en las siguientes fechas y horarios:)*

**EARLY VOTING LOCATIONS:**

(Localizaciones de Votación Adelantada):

Beaumont Courthouse-Main location	1085 Pearl St., ( <i>Lobby</i> ), Beaumont, TX
Port Arthur Sub-Courthouse	525 Lakeshore Dr. ( <i>Foyer</i> ), Port Arthur, TX
Rogers Park Recreation Center	6540 Gladys, Beaumont, TX
Port Arthur Library	4615 9th Ave., ( <i>Lucy Stiefel Gallery</i> ), Port Arthur, TX
Theodore Johns Library	4255 Fannett Rd., ( <i>Meeting Room</i> ), Beaumont, TX
John Paul Davis Community Center	3580 E. Lucas, Beaumont, TX
Marion & Ed Hughes Public Library	2712 Nederland Ave., ( <i>Meeting Room</i> ), Nederland, TX
Groves Activity Building	6150 39th Street, ( <i>Lounge</i> ), Groves, TX
Effie & Wilton Hebert Library	2025 Merriman St., ( <i>Community Room</i> ), Port Neches, TX
Ray Chesson Office Building	19217 FM 365, ( <i>Courtroom</i> ), Beaumont, TX
Precinct One Service Center	20215 W. Hwy. 90, ( <i>Front Conference Room</i> ), China, TX

**DATES AND HOURS FOR ALL ABOVE LOCATIONS:**

(Fechas y Horas para todas las localizaciones anteriores):

April 25 - 29 ( <i>Abril 25 - 29</i> )	Monday - Friday ( <i>Lunes - Viernes</i> )	8:00 a.m. - 5:00 p.m.
April 30 ( <i>Abril 30</i> )	Saturday ( <i>Sábado</i> )	8:00 a.m. - 5:00 p.m.
May 1 ( <i>Mayo 1</i> )	Sunday ( <i>Domingo</i> )	12:00 p.m. - 6:00 p.m.
May 2 - 3 ( <i>Mayo 2- Mayo 3</i> )	Monday - Tuesday ( <i>Lunes - Martes</i> )	7:00 a.m. - 7:00 p.m.

## EXHIBIT B

May 7th Uniform Election  
(Elección uniforme del 7 de mayo)

May 7, 2022  
(7 de mayo de 2022)

Countywide Polling Places  
(Lugares de votación en todo el condado)

Precincts Voting at Location (Precintos de votación en el Localización)	Election Day Polling Places (Localizaciones)	ADDRESS (Dirección)	City, State, Zip code (Ciudad, Estado, Código postal)
ALL (todas)	Amelia Elementary School (Gymnasium)	565 S. Major Dr	Beaumont, TX 77707
ALL (todas)	Beaumont Municipal Airport (Conference Room)	455 Keith Rd.	Beaumont, TX 77713
ALL (todas)	Bevil Oaks City Hall	13560 River Oaks Blvd.	Bevil Oaks, TX 77713
ALL (todas)	BISD Administration Building (Boardroom)	3395 Harrison Ave.	Beaumont, TX 77706
ALL (todas)	Dishman Elementary (Gymnasium)	3475 Champions Dr.	Beaumont, TX 77707
ALL (todas)	O.C. Mike Taylor Career Center (First Floor Old Library)	2330 North St.	Beaumont, TX 77702
ALL (todas)	Precinct 1 Service Center (Front Conference Room)	20205 W. Hwy. 90	China, TX 77613
ALL (todas)	Rogers Park Community Center	6540 Gladys Ave.	Beaumont, TX 77706
ALL (todas)	Roy Guess Elementary (Hallway near Gymnasium)	8055 Voth Rd.	Beaumont, TX 77708
ALL (todas)	Hebert Library (Community Room)	2025 Merriman St.	Port Neches, TX 77651
ALL (todas)	Jefferson County WCID 10 Fire Station (Front Lobby)	2024 Spurlock Rd.	Nederland, TX 77627
ALL (todas)	Groves Public Library (Front Meeting Room)	5600 West Washington	Groves, TX 77619
ALL (todas)	Jerry Ware Airport Terminal (Conference Room off Main Lobby)	5000 Jerry Ware Dr.	Beaumont, TX 77705
ALL (todas)	Ray Chesson Office Building (Courtroom)	19217 FM 365	Beaumont, TX 77705
ALL (todas)	Jefferson County ESD #4 (Main Meeting Room)	12880 FM 365	Beaumont, TX 77705
ALL (todas)	Marion & Ed Hughes Public Library (Meeting Room)	2712 Nederland Ave.	Nederland, TX 77627
ALL (todas)	Port Neches City Hall (Council Chambers - Room 104)	1005 Merriman	Port Neches, TX 77651
ALL (todas)	Groves Activity Building (Lounge)	6150 39th Street.	Groves, TX 77619
ALL (todas)	DeQueen Elementary (Fifth Grade Hall)	740 DeQueen Blvd.	Port Arthur, TX 77640
ALL (todas)	Zion Hill Baptist Church (Education Building)	5848 Roosevelt Ave.	Port Arthur, TX 77640
ALL (todas)	Jefferson County Sub-Courthouse (Foyer)	525 Lakeshore Dr.	Port Arthur, TX 77640
ALL (todas)	Former Dowling Elementary Campus (Library)	6301 Pat Ave	Port Arthur, TX 77640
ALL (todas)	O.W. Collins Retirement Center (Social Service Room)	4440 Gulfway Dr.	Port Arthur, TX 77642
ALL (todas)	Port Arthur Library (Lucy Stiefel Gallery)	4615 9th Ave	Port Arthur, TX 77642
ALL (todas)	Queen of Vietnam Catholic Church (St. Joseph Hall)	801 9th Ave	Port Arthur, TX 77642
ALL (todas)	R.L. Gabby Eldridge Center	5262 S. Gulfway Dr	Sabine Pass, TX 77655
ALL (todas)	Travis Elementary (Library)	1115 Lakeview Ave.	Port Arthur, TX 77642
ALL (todas)	Willie Ryman Community Center	3248 39th Street	Port Arthur, TX 77642
ALL (todas)	Alice Keith Park Recreation Center	4075 Highland Ave.	Beaumont, TX 77705
ALL (todas)	Charlton-Pollard Elementary (Gymnasium)	825 Jackson St.	Beaumont, TX 77701
ALL (todas)	Lamar University Montagne Center, (Cardinal Club Room)	4401 S. MLK PKWY	Beaumont, TX 77705
ALL (todas)	Hamshire VFD and Community Center	12318 2nd St.	Hamshire, TX 77622
ALL (todas)	Jefferson County Courthouse (Lobby)	1085 Pearl St.	Beaumont, TX 77701
ALL (todas)	MLK Middle School (Gymnasium)	1400 Avenue A	Beaumont, TX 77701
ALL (todas)	John Paul Davis Community Center	3580 E. Lucas Dr.	Beaumont, TX 77703
ALL (todas)	Precinct 4 Service Center (Conference Room)	7780 Boyd Rd.	Beaumont, TX 77713
ALL (todas)	Sterling Pruitt Center (Multi-purpose Room)	2930 Gulf St.	Beaumont, TX 77703
ALL (todas)	Theodore Johns Library (Meeting Room)	4255 Fannett Rd.	Beaumont, TX 77705
	**Denotes Change		

## EXHIBIT C

**CALENDAR**

The Political Subdivision agrees that timing is critical, and lack of adherence to this CALENDAR without prior agreement of Contracting Officer may result in additional charges or cancellation of Contracting Officer's duties and obligations to conduct Political Subdivision's election under this Contract.

**School Districts must adhere to all deadlines, even if on Spring Break.**

Please refer to the Texas Secretary of State's website for a complete calendar of events including citations to the Texas Election Code and for information specific to entity type. Confer with your attorney on any statutes that govern your entity. Please comply with all orders, postings and notices as required for your Political Subdivision. Contracting Officer will provide the publication of one Notice of Public Test in English and Spanish.

**March 7, 2022**

Prior to March 7, 2022, each Political Subdivision is responsible for validating with the Voter Registrar that the boundaries for their voting precincts are correct and supplying the Contracting Officer with a map of such boundaries.

**68<sup>th</sup> day before Election Day**

Recommended date to conduct ballot position drawing.

Notice of ballot position drawing must be posted for 72 hours immediately preceding time of drawing.

**\*\*Please schedule ballot drawing as soon as possible and email the BALLOT FORMAT AND ORDER OF CANDIDATES ON BALLOT to Contracting Officer at [countyclerk@co.jefferson.tx.us](mailto:countyclerk@co.jefferson.tx.us).\*\***

**60th day before Election Day**

Last day for the governing body of a political subdivision to deliver notice of the election to the county clerk/elections administrator and voter registrar of each county in which the political subdivision is wholly or partly located. (Sec. 4.008).

Deadline to notify Contracting Officer via email of the following items:

- whether or not Political Subdivision has a **contested election**.
- **candidate names**, including **write-in candidates**.
- any **candidate withdrawals** or **election cancellation**.
- **order of candidates on ballot**. (We prefer to receive it sooner if it is available.)
- **Spanish translations** of all ballot titles, contests, and ballot language.
- **phonetic pronunciations** of all candidate names which will be used for the ballot audio recording.

#### **60th day before Election Day - Continued**

Deadline to **cancel election** and incur **no fees** under the Election Services Agreement.

Deadline to receive executed **Election Services Agreement** by mail, personal delivery, or email.

Deadline to receive copy of **Order of Election**.

Contracting Officer contact information:

Email:	<a href="mailto:countyclerk@co.jefferson.tx.us">countyclerk@co.jefferson.tx.us</a>
Mail:	P. O. Box 1151, Beaumont, TX 77704-1151
Hand Delivery:	1085 Pearl Street, First Floor, Beaumont, Texas 77701

If additional time is needed because of meeting schedules, please notify us.

**\*\*Deadlines for ballot proofing and ballot approval will be emailed with ballot proofs. The parties must adhere to deadlines of 24 hour turnaround time, even if they occur during Spring Break, in order for our office to meet the State and Federal deadlines to mail military and overseas ballots.\*\***

#### **45th day before Election Day**

Deadline to mail ballots to military or overseas voters who submitted their ballot request via a federal postcard application (FPCA) or via a standard application for ballot by mail and indicated that they are outside the United States. Ballots must be mailed by this date or the 7th day after the clerk receives the application. If the early voting clerk cannot meet this 45th-day deadline, the clerk must notify the Secretary of State within 24 hours. (Sec. 86.004(b)).

**30th day before Election Day**

Last day to register to vote or make a change of address effective for the election. (Secs. 13.143, 15.025).

First day of period during which notice of election must be published if the method of giving notice is **not** specified by a law outside the Election Code, and **publication** is the selected method of giving notice. (Sec. 4.003(a)(1)). The notice of election ordered by an authority of a city or school district, must be given by publication in a newspaper in addition to any other method specified. (Secs. 4.003(c) and (d)).

**21st day before Election Day**

Last day to post notice of election on bulletin board used for posting notices of meetings of governing body. (Sec. 4.003(b)). A [Record of Posting Notice of Election \(PDF\)](#) should be completed at the time of posting. (Sec. 4.005).

**12th day before Election Day**

First day to vote early in person. (Sec. 85.001(a)).

**NOTE - Political Subdivisions Other than Cities and Counties:** Early voting in person must be conducted at least eight (8) hours each weekday that is not a legal state holiday unless the political subdivision has fewer than 1,000 registered voters, in which case early voting in person must be conducted at least three (3) hours per day. (Sec. 85.005(b)).

**NOTE – Cities and counties:** Early voting in person must be conducted on the weekdays of the early voting period and during the hours that the county clerk’s or city secretary’s main business office is regularly open for business. (Sec. 85.005(a)). However, because cities and counties must have office hours for election-related business at least three (3) hours every business day for this type of election, we harmonize these requirements with the result that, if a city or county is not regularly open for business on one or more weekdays, on those “closed” days, a city or county must conduct early voting for at least three (3) hours a day at the main early voting location (except for a city’s two 12-hour days, when it must be open for the full 12 hours).

**NOTE - Cities:** Cities **must** choose two (2) weekdays for the main early voting polling place location to be open for 12 hours during the regular early voting period. City council must choose the two weekdays. (Sec. 85.005(d)).

**NOTE - Independent School Districts:** Despite the change in state law that allows an ISD to be closed on school holidays during the mandatory office hours period, you are **required** to be open during the entire early voting period, except on legal state and national holidays.

**NOTE - Joint Elections:** If entities are conducting early voting by personal appearance jointly, we *recommend* a unified schedule covering all requirements; i.e., no entity’s requirements should be neglected or subtracted as a result of a joint agreement.

**10th day before Election Day**

Last day of period during which notice of election must be published if method of giving notice is not specified by a law outside the Election Code and publication is the selected method of giving notice. (Sec. 4.003(a)(1)). The notice of election ordered by a commissioners court or by an authority of a city or school district, must be given by publication in a newspaper in addition to any other method specified. (Secs. 4.003(c) and (d)).

Last day to mail a copy of the notice of election to each registered voter in the county if method of giving notice is not specified by a law outside the Election Code and this method of giving notice is selected. (Secs. 1.006, 4.003(a)(3)).

Cities and Counties – Weekend Early Voting Hours - Notice Requirement: Last day to post notice on bulletin board used for posting notice of city council or commissioners court, if early voting will be conducted on Saturday (Sec. 85.007). Notice must be posted at least 72 hours before early voting begins on a Saturday or Sunday. Notice must also be posted to the political subdivision's website, if one is maintained.

**NOTE - NEW LAW:** Section 85.007, as amended by House Bill 2721 (2015), requires that the election notice, which includes the days and hours of early voting be posted on the political subdivision's website, if the political subdivision maintains a website.

**4th day before Election Day**

Last day to vote early by personal appearance. (Sec. 85.001(a)).

**Election Day**

Polls open 7:00 A.M. – 7:00 P.M.

**30 days from date of final invoice**

Pay balance due for election services. Please make checks payable to:

Jefferson County Treasurer  
P O Box 1151  
Beaumont, Texas 77704-1151

**EXHIBIT D**  
**CONTRACT COSTS**

<b>Voting Equipment</b>	
Judge's Booth Controller	\$330.00
eSlate	\$330.00
Disable Access Unit (DAU)	\$396.00
Privacy Booth	\$20.00
Ballot Box	\$5.00
<b>Communication Devices</b>	
EA Tablet + WIFI	\$119.50
Cell Phone	\$30.00
<b>Mandatory Signs</b>	
Large A-Frame (ID Required )	\$10.00
Large A-Frame (Notices )	\$10.00
<b>PROGRAMMING</b>	<b>COUNTY COST</b>
1 - 5 RACES	\$1,125.00
6 - 10 RACES	\$1,898.00
11-20 RACES	\$2,475.00
21-40 RACES	\$3,135.00
41-75 RACES	\$3,960.00
76-100 RACES	\$4,704.00
<b>BALLOT PRINTING</b>	<b>COUNTY COST</b>
8.5 X 11	\$0.23
8.5 X 14	\$0.25
8.5 X 17	\$0.28



Sample Ballots	\$0.06
<hr/>	
SUPPLIES	
<hr/>	
ELECTION KITS / w Seals EV & ED	\$40.00
Mail Ballots (Per Set)	\$0.75
Supply Bag Consumables (per location)	\$20.00
<hr/>	

REVISED 07/19/16

**ORDER OF SPECIAL ELECTION  
 ORDEN DE ELECCIÓN ESPECIAL**

(For Governor-Ordered or County-Ordered Measure Elections)  
 (Para órdenes de gobernador u ordenes de condado sobre elecciones medidas)

An election is hereby ordered to be held on 05 / 07 / 2022 for the purpose of voting on:  
 (date)  
 (Por la presente se ordena celebrar una elección el 05 / 07 / 2022 con el propósito de votar sobre.)  
 (fecha)

List Offices/Propositions/Measures on the ballot (Enúmere los puestos/proposiciones/medidas oficiales en la boleta)

**Proposition 1 (SJR 2 - 87th Legislature, 2nd Special Session)**

"The constitutional amendment authorizing the legislature to provide for the reduction of the amount of a limitation on the total amount of ad valorem taxes that may be imposed for general elementary and secondary public school purposes on the residence homestead of a person who is elderly or disabled to reflect any statutory reduction from the preceding tax year in the maximum compressed rate of the maintenance and operations taxes imposed for those purposes on the homestead."

**Proposition 2 (SJR 2 - 87th Legislature, 3rd Special Session)**

"The constitutional amendment increasing the amount of the residence homestead exemption from ad valorem taxation for public school purposes from \$25,000 to \$40,000."

--

Early voting by personal appearance will be conducted each weekday at:  
 (La votación adelantada en persona se llevará a cabo de lunes a viernes en:)

The Main Early Voting Location (sitio principal de votación adelantada)

Location (sitio)	Hours (horas)
Jefferson County Courthouse	4/25 - 4/29 8 AM - 5 PM, 5/2 - 5/3 7 AM - 7 PM

Branch Early Voting Locations (sucursal sitios de votación adelantada)

Location (sitio)	Hours (horas)
SEE ATTACHED LIST	

Early voting by personal appearance will be conducted each weekend at:  
 (La votación adelantada en persona se llevará a cabo en el fin de semana en:)

The Main Early Voting Location (sitio principal de votación adelantada)

Location (sitio)	Hours (horas)
Jefferson County Courthouse	Sat. 8am to 5pm, Sun. 12pm to 6pm

Branch Early Voting Locations (sucursal sitios de votación adelantada)

Location (sitio)	Hours (horas)
SEE ATTACHED LIST	

Applications for ballot by mail shall be mailed to:  
 (Las solicitudes para boletas que se votarán adelantada por correo deberán enviarse a:)

Laurie Leister

Name of Early Voting Clerk  
 (Nombre del Secretario/a de la Votación Adelantada)

1085 Pearl Street  
 Address (Dirección)

Beaumont, Texas 77701  
 City (Ciudad) Zip Code (Código Postal)

409-835-8760  
 Telephone Number (Número de teléfono)  
 countyclerk@co.jefferson.tx.us

Email Address (Dirección de Correo Electrónico)

www.jeffersonelections.com  
 Early Voting Clerk's Website (Sitio web del Secretario/a de Votación Adelantada)

Applications for Ballots by Mail (ABBMs) must be received no later than the close of business on:  
 (Las solicitudes para boletas que se votarán adelantada por correo deberán recibirse no más tardar de las horas de negocio el:)

April / 26 / 2022  
 (date)(fecha)

Federal Post Card Applications (FPCAs) must be received no later than the close of business on:  
 (La Tarjeta Federal Postal de Solicitud deberán recibirse no más tardar de las horas de negocio el:)

April / 26 / 2022  
 (date)(fecha)

Issued this 15th day of February, 20 22.  
 (day) (month) (year)

(Emitida este día 15th de February, 20 22.)  
 (día) (mes) (año)

[Signature]  
 Signature of County Judge  
 (Firma del Juez del Condado)

[Signature]

Signature of Commissioner  
 (Firma del Comisionado)

[Signature]

Signature of Commissioner  
 (Firma del Comisionado)

[Signature]

Signature of Commissioner  
 (Firma del Comisionado)

[Signature]

Signature of Commissioner  
 (Firma del Comisionado)

**NOTICE OF EARLY VOTING LOCATIONS AND HOURS FOR**  
**May 7, 2022, CONSTITUTIONAL AMENDMENT AND JOINT ELECTION**  
**(Aviso de localizaciones y horas para elecciones adelantadas de Mayo 7, 2022**  
**Sobre Enmiendas A La Constitución y Conjunta)**

Early Voting by personal appearance will be conducted at the following dates and times:  
*(La votación adelantada en persona se llevará a en las siguientes fechas y horarios:)*

**EARLY VOTING LOCATIONS:**

(Localizaciones de Votación Adelantada):

Beaumont Courthouse-Main location	1085 Pearl St., ( <i>Lobby</i> ), Beaumont, TX
Port Arthur Sub-Courthouse	525 Lakeshore Dr. ( <i>Foyer</i> ), Port Arthur, TX
Rogers Park Recreation Center	6540 Gladys, Beaumont, TX
Port Arthur Library	4615 9th Ave., ( <i>Lucy Stiefel Gallery</i> ), Port Arthur, TX
Theodore Johns Library	4255 Fannett Rd., ( <i>Meeting Room</i> ), Beaumont, TX
John Paul Davis Community Center	3580 E. Lucas, Beaumont, TX
Marion & Ed Hughes Public Library	2712 Nederland Ave., ( <i>Meeting Room</i> ), Nederland, TX
Groves Activity Building	6150 39th Street, ( <i>Lounge</i> ), Groves, TX
Effie & Wilton Hebert Library	2025 Merriman St., ( <i>Community Room</i> ), Port Neches, TX
Ray Chesson Office Building	19217 FM 365, ( <i>Courtroom</i> ), Beaumont, TX
Precinct One Service Center	20215 W. Hwy. 90, ( <i>Front Conference Room</i> ), China, TX

**DATES AND HOURS FOR ALL ABOVE LOCATIONS:**

(Fechas y Horas para todas las localizaciones anteriores):

April 25 - 29 ( <i>Abril 25 - 29</i> )	Monday - Friday ( <i>Lunes -Viernes</i> )	8:00 a.m. - 5:00 p.m.
April 30 ( <i>Abril 30</i> )	Saturday ( <i>Sábado</i> )	8:00 a.m. - 5:00 p.m.
May 1 ( <i>Mayo 1</i> )	Sunday ( <i>Domingo</i> )	12:00 p.m. – 6:00 p.m.
May 2 - 3 ( <i>Mayo 2- Mayo 3</i> )	Monday – Tuesday ( <i>Lunes – Martes</i> )	7:00 a.m. - 7:00 p.m.

Precincts Voting at Location (Precintos de votación en el Localización)	Election Day Polling Places (Localizaciones)	ADDRESS (Dirección)	City, State, Zip code (Ciudad, Estado, Código postal)
ALL (todos)	Amelia Elementary School (Gymnasium)	565 S. Major Dr	Beaumont, TX 77707
ALL (todos)	Beaumont Municipal Airport (Conference Room)	455 Keith Rd.	Beaumont, TX 77713
ALL (todos)	Bevil Oaks City Hall	13560 River Oaks Blvd.	Bevil Oaks, TX 77713
ALL (todos)	BISD Administration Building (Boardroom)	3395 Harrison Ave.	Beaumont, TX 77706
ALL (todos)	Dishman Elementary (Gymnasium)	3475 Champions Dr.	Beaumont, TX 77707
ALL (todos)	O.C. Mike Taylor Career Center (First Floor Old Library)	2330 North St.	Beaumont, TX 77702
ALL (todos)	Precinct 1 Service Center (Front Conference Room)	20205 W. Hwy. 90	China, TX 77613
ALL (todos)	Rogers Park Community Center	6540 Gladys Ave.	Beaumont, TX 77706
ALL (todos)	Roy Guess Elementary (Hallway near Gymnasium)	8055 Voth Rd.	Beaumont, TX 77708
ALL (todos)	Hebert Library (Community Room)	2025 Merriman St.	Port Neches, TX 77651
ALL (todos)	Jefferson County WCID 10 Fire Station (Front Lobby)	2024 Spurlock Rd.	Nederland, TX 77627
ALL (todos)	Groves Public Library (Front Meeting Room)	5600 West Washington	Groves, TX 77619
ALL (todos)	Jerry Ware Airport Terminal (Conference Room off Main Lobby)	5000 Jerry Ware Dr.	Beaumont, TX 77705
ALL (todos)	Ray Chesson Office Building (Courtroom)	19217 FM 365	Beaumont, TX 77705
ALL (todos)	Jefferson County ESD #4 (Main Meeting Room)	12880 FM 365	Beaumont, TX 77705
ALL (todos)	Marion & Ed Hughes Public Library (Meeting Room)	2712 Nederland Ave.	Nederland, TX 77627
ALL (todos)	Port Neches City Hall (Council Chambers - Room 104)	1005 Merriman	Port Neches, TX 77651
ALL (todos)	Groves Activity Building (Lounge)	6150 39th Street.	Groves, TX 77619
ALL (todos)	DeQueen Elementary (Fifth Grade Hall)	740 DeQueen Blvd.	Port Arthur, TX 77640
ALL (todos)	Zion Hill Baptist Church (Education Building)	5848 Roosevelt Ave.	Port Arthur, TX 77640
ALL (todos)	Jefferson County Sub-Courthouse (Foyer)	525 Lakeshore Dr.	Port Arthur, TX 77640
ALL (todos)	Former Dowling Elementary Campus (Library)	6301 Pat Ave	Port Arthur, TX 77640
ALL (todos)	O.W. Collins Retirement Center (Social Service Room)	4440 Gulfway Dr.	Port Arthur, TX 77642
ALL (todos)	Port Arthur Library (Lucy Stiefel Gallery)	4615 9th Ave	Port Arthur, TX 77642
ALL (todos)	Queen of Vietnam Catholic Church (St. Joseph Hall)	801 9th Ave	Port Arthur, TX 77642
ALL (todos)	R.L. Gabby Eldridge Center	5262 S. Gulfway Dr	Sabine Pass, TX 77655
ALL (todos)	Travis Elementary (Library)	1115 Lakeview Ave.	Port Arthur, TX 77642
ALL (todos)	Willie Ryman Community Center	3248 39th Street	Port Arthur, TX 77642
ALL (todos)	Alice Keith Park Recreation Center	4075 Highland Ave.	Beaumont, TX 77705
ALL (todos)	Charlton-Pollard Elementary (Gymnasium)	825 Jackson St.	Beaumont, TX 77701
ALL (todos)	Lamar University Montagne Center, (Cardinal Club Room)	4401 S. MLK PKWY	Beaumont, TX 77705
ALL (todos)	Hamshire VFD and Community Center	12318 2nd St.	Hamshire, TX 77622
ALL (todos)	Jefferson County Courthouse (Lobby)	1085 Pearl St.	Beaumont, TX 77701
ALL (todos)	MLK Middle School (Gymnasium)	1400 Avenue A	Beaumont, TX 77701
ALL (todos)	John Paul Davis Community Center	3580 E. Lucas Dr.	Beaumont, TX 77703
ALL (todos)	Precinct 4 Service Center (Conference Room)	7780 Boyt Rd.	Beaumont, TX 77713
ALL (todos)	Sterling Pruitt Center (Multi-purpose Room)	2930 Gulf St.	Beaumont, TX 77703
ALL (todos)	Theodore Johns Library (Meeting Room)	4255 Fannett Rd.	Beaumont, TX 77705
	**Denotes Change		

**NOTICE OF SPECIAL ELECTION (COUNTY)  
 AVISO DE ELECCIÓN ESPECIAL (CONDADO)**

To the registered voters of the County of Jefferson County, Texas:

*(A los votantes registrados del Condado de Jefferson County, Texas)*

Notice is hereby given that the polling places listed below will be open from 7:00 a.m. to 7:00 p.m.,  
May / 7 / 2022 for voting in a special election to elect:

SEE CONSTITUTIONAL AMENDMENTS ATTACHED

*(Notifíquese por la presente, que los sitios de votación citadas abajo se abrirán desde las 7:00 a.m. hasta las 7:00 p.m. el May / 7 / 2022 para votar en la elección especial para elegir:*

SEE CONSTITUTIONAL AMENDMENTS ATTACHED

**On Election Day, voters must vote in the precinct where registered to vote, unless the countywide polling place program is being used in the election.**

***(El Día de Elección, los votantes deberán votar en el precinto donde están inscritos para votar, a menos que el programa de sitios de votación del condado se está utilizando en la elección.)***

Location of Election Day Polling Places Include Name of Building and Address <i>(Sitios de votación el Día de Elección)</i> <i>(Incluir Nombre del Edificio y Dirección)</i>	Precinct Number(s) <i>(Número de precinto)</i>
SEE ATTACHED	

**During early voting, a voter may vote at any of the locations listed below:**  
***(Durante Votación Adelantada, los votantes podrán votar en cualquiera de los sitios de votación nombradas abajo.)***

Location of Main Early Voting Polling Place Include Name of Building and Address <i>(Sitio principal de votación adelantada)</i> <i>(Incluir Nombre del Edificio y Dirección)</i>	Days and Hours of Operation <i>Días y Horas Hábiles</i>
JEFFERSON COUNTY COURTHOUSE	4/25-4/29 8AM-5PM, 5/2-5/3 7AM-7PM

Locations for Early Voting Polling Places Include Name of Building and Address <i>(Sitios de votación adelantada)</i> <i>(Incluir Nombre del Edificio y Dirección)</i>	Days and Hours of Operation <i>Días y Horas Hábiles</i>
SEE ATTACHED	

Applications for ballot by mail shall be mailed to:  
*(Las solicitudes para boletas que se votarán adelantada por correo deberán enviarse a:)*

LAURIE LEISTER

Name of Early Voting Clerk  
*(Nombre del Secretario/a de la Votación Adelantada)*

1085 PEARL STREET

Address *(Dirección)*

BEAUMONT, TX 77706

City *(Ciudad)* Zip Code *(Código Postal)*

409-835-8760

Telephone Number *(Número de teléfono)*

COUNTYCLERK@CO.JEFFERSON.TX.US

Email Address *(Dirección de Correo Electrónico)*

WWW.JEFFERSONELECTIONS.COM

Early Voting Clerk's Website *(Sitio web del Secretario/a de Votación Adelantada)*

Applications for Ballots by Mail (ABBM)s must be received no later than the close of business on:  
*(Las solicitudes para boletas que se votarán adelantada por correo deberán recibirse no más tardar de las horas de negocio el:)*

05 / 26 / 2022  
 (date)(fecha)

Federal Post Card Applications (FPCAs) must be received no later than the close of business on:  
*(La Tarjeta Federal Postal de Solicitud deberán recibirse no más tardar de las horas de negocio el:)*

Issued this 15 day of February, 20 22.  
 (day) (month) (year)

*(Emitada este día 15 de February, 20 22.)*  
 (día) (mes) (año)

Signature of County Judge *(Firma del Juez del Condado)*

## **CONSTITUTIONAL AMENDMENTS FOR THE MAY 7, 2022 ELECTION**

### **Proposition 1 (SJR 2 - 87th Legislature, 2nd Special Session)**

*“The constitutional amendment authorizing the legislature to provide for the reduction of the amount of a limitation on the total amount of ad valorem taxes that may be imposed for general elementary and secondary public school purposes on the residence homestead of a person who is elderly or disabled to reflect any statutory reduction from the preceding tax year in the maximum compressed rate of the maintenance and operations taxes imposed for those purposes on the homestead.”*

### **Proposition 2 (SJR 2 - 87th Legislature, 3rd Special Session)**

*“The constitutional amendment increasing the amount of the residence homestead exemption from ad valorem taxation for public school purposes from \$25,000 to \$40,000.”*



**NOTICE OF EARLY VOTING LOCATIONS AND HOURS FOR**  
**May 7, 2022, CONSTITUTIONAL AMENDMENT AND JOINT ELECTION**  
**(Aviso de localizaciones y horas para elecciones adelantadas de Mayo 7, 2022**  
**Sobre Enmiendas A La Constitución y Conjunta)**

Early Voting by personal appearance will be conducted at the following dates and times:  
*(La votación adelantada en persona se llevará a en las siguientes fechas y horarios:)*

**EARLY VOTING LOCATIONS:**

(Localizaciones de Votación Adelantada):

Beaumont Courthouse-Main location	1085 Pearl St., ( <i>Lobby</i> ), Beaumont, TX
Port Arthur Sub-Courthouse	525 Lakeshore Dr. ( <i>Foyer</i> ), Port Arthur, TX
Rogers Park Recreation Center	6540 Gladys, Beaumont, TX
Port Arthur Library	4615 9th Ave., ( <i>Lucy Stiefel Gallery</i> ), Port Arthur, TX
Theodore Johns Library	4255 Fannett Rd., ( <i>Meeting Room</i> ), Beaumont, TX
John Paul Davis Community Center	3580 E. Lucas, Beaumont, TX
Marion & Ed Hughes Public Library	2712 Nederland Ave., ( <i>Meeting Room</i> ), Nederland, TX
Groves Activity Building	6150 39th Street, ( <i>Lounge</i> ), Groves, TX
Effie & Wilton Hebert Library	2025 Merriman St., ( <i>Community Room</i> ), Port Neches, TX
Ray Chesson Office Building	19217 FM 365, ( <i>Courtroom</i> ), Beaumont, TX
Precinct One Service Center	20215 W. Hwy. 90, ( <i>Front Conference Room</i> ), China, TX

**DATES AND HOURS FOR ALL ABOVE LOCATIONS:**

(Fechas y Horas para todas las localizaciones anteriores):

April 25 - 29 ( <i>Abril 25 - 29</i> )	Monday - Friday ( <i>Lunes -Viernes</i> )	8:00 a.m. - 5:00 p.m.
April 30 ( <i>Abril 30</i> )	Saturday ( <i>Sábado</i> )	8:00 a.m. - 5:00 p.m.
May 1 ( <i>Mayo 1</i> )	Sunday ( <i>Domingo</i> )	12:00 p.m. – 6:00 p.m.
May 2 - 3 ( <i>Mayo 2- Mayo 3</i> )	Monday – Tuesday ( <i>Lunes – Martes</i> )	7:00 a.m. - 7:00 p.m.

Precincts Voting at Location (Precintos de votación en el Localización)	Election Day Polling Places (Localizaciones)	ADDRESS (Dirección)	City, State, Zip code (Ciudad, Estado, Código postal)
ALL (todos)	Amelia Elementary School (Gymnasium)	565 S. Major Dr	Beaumont, TX 77707
ALL (todos)	Beaumont Municipal Airport (Conference Room)	455 Keith Rd.	Beaumont, TX 77713
ALL (todos)	Bevil Oaks City Hall	13560 River Oaks Blvd.	Bevil Oaks, TX 77713
ALL (todos)	BISD Administration Building (Boardroom)	3395 Harrison Ave.	Beaumont, TX 77706
ALL (todos)	Dishman Elementary (Gymnasium)	3475 Champions Dr.	Beaumont, TX 77707
ALL (todos)	O.C. Mike Taylor Career Center (First Floor Old Library)	2330 North St.	Beaumont, TX 77702
ALL (todos)	Precinct 1 Service Center (Front Conference Room)	20205 W. Hwy. 90	China, TX 77613
ALL (todos)	Rogers Park Community Center	6540 Gladys Ave.	Beaumont, TX 77706
ALL (todos)	Roy Guess Elementary (Hallway near Gymnasium)	8055 Voth Rd.	Beaumont, TX 77708
ALL (todos)	Hebert Library (Community Room)	2025 Merriman St.	Port Neches, TX 77651
ALL (todos)	Jefferson County WCID 10 Fire Station (Front Lobby)	2024 Spurlock Rd.	Nederland, TX 77627
ALL (todos)	Groves Public Library (Front Meeting Room)	5600 West Washington	Groves, TX 77619
ALL (todos)	Jerry Ware Airport Terminal (Conference Room off Main Lobby)	5000 Jerry Ware Dr.	Beaumont, TX 77705
ALL (todos)	Ray Chesson Office Building (Courtroom)	19217 FM 365	Beaumont, TX 77705
ALL (todos)	Jefferson County ESD #4 (Main Meeting Room)	12880 FM 365	Beaumont, TX 77705
ALL (todos)	Marion & Ed Hughes Public Library (Meeting Room)	2712 Nederland Ave.	Nederland, TX 77627
ALL (todos)	Port Neches City Hall (Council Chambers - Room 104)	1005 Merriman	Port Neches, TX 77651
ALL (todos)	Groves Activity Building (Lounge)	6150 39th Street.	Groves, TX 77619
ALL (todos)	DeQueen Elementary (Fifth Grade Hall)	740 DeQueen Blvd.	Port Arthur, TX 77640
ALL (todos)	Zion Hill Baptist Church (Education Building)	5848 Roosevelt Ave.	Port Arthur, TX 77640
ALL (todos)	Jefferson County Sub-Courthouse (Foyer)	525 Lakeshore Dr.	Port Arthur, TX 77640
ALL (todos)	Former Dowling Elementary Campus (Library)	6301 Pat Ave	Port Arthur, TX 77640
ALL (todos)	O.W. Collins Retirement Center (Social Service Room)	4440 Gulfway Dr.	Port Arthur, TX 77642
ALL (todos)	Port Arthur Library (Lucy Stiefel Gallery)	4615 9th Ave	Port Arthur, TX 77642
ALL (todos)	Queen of Vietnam Catholic Church (St. Joseph Hall)	801 9th Ave	Port Arthur, TX 77642
ALL (todos)	R.L. Gabby Eldridge Center	5262 S. Gulfway Dr	Sabine Pass, TX 77655
ALL (todos)	Travis Elementary (Library)	1115 Lakeview Ave.	Port Arthur, TX 77642
ALL (todos)	Willie Ryman Community Center	3248 39th Street	Port Arthur, TX 77642
ALL (todos)	Alice Keith Park Recreation Center	4075 Highland Ave.	Beaumont, TX 77705
ALL (todos)	Charlton-Pollard Elementary (Gymnasium)	825 Jackson St.	Beaumont, TX 77701
ALL (todos)	Lamar University Montagne Center, (Cardinal Club Room)	4401 S. MLK PKWY	Beaumont, TX 77705
ALL (todos)	Hamshire VFD and Community Center	12318 2nd St.	Hamshire, TX 77622
ALL (todos)	Jefferson County Courthouse (Lobby)	1085 Pearl St.	Beaumont, TX 77701
ALL (todos)	MLK Middle School (Gymnasium)	1400 Avenue A	Beaumont, TX 77701
ALL (todos)	John Paul Davis Community Center	3580 E. Lucas Dr.	Beaumont, TX 77703
ALL (todos)	Precinct 4 Service Center (Conference Room)	7780 Boyt Rd.	Beaumont, TX 77713
ALL (todos)	Sterling Pruitt Center (Multi-purpose Room)	2930 Gulf St.	Beaumont, TX 77703
ALL (todos)	Theodore Johns Library (Meeting Room)	4255 Fannett Rd.	Beaumont, TX 77705
	**Denotes Change		

## NOTICE OF CONVING OF EARLY VOTING BALLOT BOARD

The Early Voting Ballot Board will convene on the following dates:

**Friday, February 18, 2022 at 9:00 am**

**Friday, February 25, 2022 at 9:00 am**

**Tuesday, March 1, 2022 at 11:30 am**

**Tuesday, March 1, 2022 at 7:45 pm**

**Tuesday, March 8, 2022 at 10:30 am**

For the purpose of qualifying and/or counting, the early voting ballots cast in the election held on **March 1, 2022**.

The board will meet at the Jefferson County Election Barn, 7963 Viterbo Road, Beaumont, Texas 77705.

You are hereby instructed to deliver all election materials, ballots voted by mail, double locked ballot boxes, and the keys to the ballot boxes to me at the designated time above.

Last Name	First Name	Address	City	State	Zip	
CARR	DINA	2225 STILLWATER DRIVE	BEAUMONT	TX	77705	Co-Chair
SIMONEAUX	CLIFTON	223 AVENUE D	NEDERLAND	TX	77627	
MORGAN	MARSHA	105 S 1ST STREET	NEDERLAND	TX	77627	
GEBAUER	DONALD	PO BOX 1928	NEDERLAND	TX	77627	
GREENE	PATRICIA	2225 STILLWATER DRIVE	BEAUMONT	TX	77705	
MAGGIO	MARIE	6279 IVANHOE LANE	BEAUMONT	TX	77706	
HALL	ANN	8265 LAKE PLACID DRIVE	NEDERLAND	TX	77627	
WILLIAMS	LAIJUNDA	1908 DETROIT AVE	NEDERLAND	TX	77627	
FOREY	HOPE	1502 HAMILTON COURT DR	NEDERLAND	TX	77627	
FOREY	LEONARD	2300 SAYBROOK LANE	PORT NECHES	TX	77651	
DRAKE	CYNTHIA	4621 BOYD AVENUE	GROVES	TX	77619	Alt
BROWN	LINDA	501 GLORIA COURT	PORT NECHES	TX	77651	Alt
HENDERSON	DORIS ELAINE	6260 REGINA LANE	BEAUMONT	TX	77706	Alt
STAFFORD	JOHN	6885 SHANAHAN DRIVE	BEAUMONT	TX	77706	Co-Chair
HATCHER	BEVERLY	7 SANDLEWOOD TRAIL	BEAUMONT	TX	77706	
CALDWELL	BEVERLY	2190 LELA STREET	BEAUMONT	TX	77705	
PHILLIPS	FREDERICKA	3260 BENDER	BEAUMONT	TX	77705	
KIRKWOOD	MARY	984 SUNMEADOW DRIVE	BEAUMONT	TX	77706	
DURDEN	JOHNNIE M	16436 WESTBURY ROAD	BEAUMONT	TX	77713	
EVANS	FLORENCE	5195 LINDA LANE	BEAUMONT	TX	77708	
FERMON	RASHIDA	9350 ROSLYN CT	BEAUMONT	TX	77708	
WELLS	ALESHA	5070 ROSEMARY DR	BEAUMONT	TX	77708	
YOUNG	PAT	7475 OAKS LANE	BEAUMONT	TX	77708	
HUGHES	DEVA	2010 SARAH ST	BEAUMONT	TX	77705	Alt
SIGEE	THOMAS	2465 LAUREL APT 84	BEAUMONT	TX	77702	Alt
HOLMES	GLENN	9208 RIGGS	BEAUMONT	TX	77707	Alt

Early Voting Ballot Board for March 2022 Primary Election

**NOTICE OF EARLY VOTING LOCATIONS AND HOURS FOR**  
**March 1, 2022, GENERAL PRIMARY ELECTION**  
**(Aviso de lugares horario de votación anticipada 1 de marzo de 2022, Elección Primaria**  
**General)**

Early Voting by personal appearance will be conducted at the following dates and times:  
*(La votación adelantada en persona se llevará a en las siguientes fechas y horarios:)*

**EARLY VOTING LOCATIONS:**

*(Localizaciones de Votación Adelantada):*

Beaumont Courthouse-Main location	1085 Pearl St., <i>(Lobby)</i> , Beaumont, TX
Port Arthur Sub-Courthouse	525 Lakeshore Dr. <i>(Foyer)</i> , Port Arthur, TX
Rogers Park Recreation Center	6540 Gladys, Beaumont, TX
Port Arthur Library	4615 9th Ave., <i>(Lucy Stiefel Gallery)</i> , Port Arthur, TX
Theodore Johns Library	4255 Fannett Rd., <i>(Meeting Room)</i> , Beaumont, TX
John Paul Davis Community Center	3580 E. Lucas, Beaumont, TX
Marion & Ed Hughes Public Library	2712 Nederland Ave., <i>(Meeting Room)</i> , Nederland, TX
Groves Activity Building	6150 39th Street, <i>(Lounge)</i> , Groves, TX
Effie & Wilton Hebert Library	2025 Merriman St., <i>(Community Room)</i> , Port Neches, TX
Ray Chesson Office Building	19217 FM 365, <i>(Courtroom)</i> , Beaumont, TX
Precinct One Service Center	20215 W. Hwy. 90, <i>(Front Conference Room)</i> , China, TX

**DATES AND HOURS FOR ALL ABOVE LOCATIONS:**

*(Fechas y Horas para todas las localizaciones anteriores):*

February 14 – February 18 <i>(Febrero 14 - 18)</i>	Monday - Friday <i>(Lunes -Viernes)</i>	8:00 a.m. - 5:00 p.m.
February 19 <i>(Febrero 19)</i>	Saturday <i>(Sábado)</i>	7:00 a.m. - 7:00 p.m.
February 20 <i>(Febrero 20)</i>	Sunday <i>(Domingo)</i>	12:00 p.m. - 6:00 p.m.
February 22 – February 25 <i>(Febrero 22 – 25)</i>	Tuesday – Friday <i>(Martes – Viernes)</i>	7:00 a.m. – 7:00 p.m.

Precincts Voting at Location (Precintos de votación en el Localización)	Election Day Polling Places (Localizaciones)	ADDRESS (Dirección)	City, State, Zip code (Ciudad, Estado, Código postal)
ALL (todos)	Amelia Elementary School (Gymnasium)	565 S. Major Dr	Beaumont, TX 77707
ALL (todos)	Beaumont Municipal Airport (Conference Room)	455 Keith Rd.	Beaumont, TX 77713
ALL (todos)	Bevil Oaks City Hall	13560 River Oaks Blvd.	Bevil Oaks, TX 77713
ALL (todos)	BISD Administration Building (Boardroom)	3395 Harrison Ave.	Beaumont, TX 77706
ALL (todos)	Dishman Elementary (Gymnasium)	3475 Champions Dr.	Beaumont, TX 77707
ALL (todos)	O.C. Mike Taylor Career Center (First Floor Old Library)	2330 North St.	Beaumont, TX 77702
ALL (todos)	Precinct 1 Service Center (Front Conference Room)	20205 W. Hwy. 90	China, TX 77613
ALL (todos)	Rogers Park Community Center	6540 Gladys Ave.	Beaumont, TX 77706
ALL (todos)	Roy Guess Elementary (Hallway near Gymnasium)	8055 Voth Rd.	Beaumont, TX 77708
ALL (todos)	Hebert Library (Community Room)	2025 Merriman St.	Port Neches, TX 77651
ALL (todos)	Jefferson County WCID 10 Fire Station (Front Lobby)	2024 Spurlock Rd.	Nederland, TX 77627
ALL (todos)	Groves Public Library (Front Meeting Room)	5600 West Washington	Groves, TX 77619
ALL (todos)	Nederland City Hall	207 N. 12th Street	Nederland, TX 77627
ALL (todos)	Jerry Ware Airport Terminal (Conference Room off Main Lobby)	5000 Jerry Ware Dr.	Beaumont, TX 77705
ALL (todos)	Ray Chesson Office Building (Courtroom)	19217 FM 365	Beaumont, TX 77705
ALL (todos)	Jefferson County ESD #4 (Main Meeting Room)	12880 FM 365	Beaumont, TX 77705
ALL (todos)	Marion & Ed Hughes Public Library (Meeting Room)	2712 Nederland Ave.	Nederland, TX 77627
ALL (todos)	Port Neches City Hall (Council Chambers - Room 104)	1005 Merriman	Port Neches, TX 77651
ALL (todos)	Groves Activity Building (Lounge)	6150 39th Street.	Groves, TX 77619
ALL (todos)	DeQueen Elementary (Fifth Grade Hall)	740 DeQueen Blvd.	Port Arthur, TX 77640
ALL (todos)	Zion Hill Baptist Church (Education Building)	5848 Roosevelt Ave.	Port Arthur, TX 77640
ALL (todos)	Jefferson County Sub-Courthouse (Foyer)	525 Lakeshore Dr.	Port Arthur, TX 77640
ALL (todos)	Former Dowling Elementary Campus (Library)	6301 Pat Ave	Port Arthur, TX 77640
ALL (todos)	O.W. Collins Retirement Center (Social Service Room)	4440 Gulfway Dr.	Port Arthur, TX 77642
ALL (todos)	Port Arthur Library (Lucy Stiefel Gallery)	4615 9th Ave	Port Arthur, TX 77642
ALL (todos)	Queen of Vietnam Catholic Church (St. Joseph Hall)	801 9th Ave	Port Arthur, TX 77642
ALL (todos)	R.L. Gabby Eldridge Center	5262 S. Gulfway Dr	Sabine Pass, TX 77655
ALL (todos)	Travis Elementary (Library)	1115 Lakeview Ave.	Port Arthur, TX 77642
ALL (todos)	Willie Ryman Community Center	3248 39th Street	Port Arthur, TX 77642
ALL (todos)	Alice Keith Park Recreation Center	4075 Highland Ave.	Beaumont, TX 77705
ALL (todos)	Charlton-Pollard Elementary (Gymnasium)	825 Jackson St.	Beaumont, TX 77701
ALL (todos)	Lamar University Montagne Center, (Cardinal Club Room)	4401 S. MLK PKWY	Beaumont, TX 77705
ALL (todos)	Hamshire VFD and Community Center	12318 2nd St.	Hamshire, TX 77622
ALL (todos)	Jefferson County Courthouse (Lobby)	1085 Pearl St.	Beaumont, TX 77701
ALL (todos)	MLK Middle School (Gymnasium)	1400 Avenue A	Beaumont, TX 77701
ALL (todos)	John Paul Davis Community Center	3580 E. Lucas Dr.	Beaumont, TX 77703
ALL (todos)	Precinct 4 Service Center (Conference Room)	7780 Boyt Rd.	Beaumont, TX 77713
ALL (todos)	Sterling Pruitt Center (Multi-purpose Room)	2930 Gulf St.	Beaumont, TX 77703
ALL (todos)	Theodore Johns Library (Meeting Room)	4255 Fannett Rd.	Beaumont, TX 77705
	**Denotes Change		

# Jefferson County Mosquito Control District

Organized in 1950

**Denise Wheeler, Director**  
8905 First Street  
Beaumont, Texas 77705  
Phone: (409) 719-5923  
Fax: (409) 727-4176  
[wheeler@co.jefferson.tx.us](mailto:wheeler@co.jefferson.tx.us)



**Advisory Commission:**  
Dr. M.O. Way, Chairman  
Jaime Batiste, Secretary  
George Mitchell  
Matt Vincent  
Reginald Boykins Sr.

**January 24, 2022**

## AERIAL WAIVER

County Judge's Office  
1149 Pearl Street  
4<sup>th</sup> Floor  
Beaumont, TX 77701

The Jefferson County Mosquito Control District is authorized to fly low altitudes as required for the application of pesticides for the control of mosquitoes within the limits of Jefferson County, Texas. Jefferson County Mosquito Control operates in accordance with all Federal and State Rules and Regulations governing this type of application.

Signature:

A handwritten signature in blue ink, appearing to read "Jeff Branick", written over a horizontal line.

Judge Jeff Branick, Jefferson County, Texas

Date:

2-15-2022

Bryan Farrar, Pilot  
Jefferson County Mosquito Control District

BF/dw

Jefferson County Courthouse  
P.O. Box 4025  
Beaumont, Texas 77704



Beaumont (409) 835-8466  
Pt. Arthur (409) 727-2191 Ext. 8466  
Facsimile (409) 839-2311

JEFF R. BRANICK  
County Judge

February 15, 2022

Ms Sharae N. Reed  
City Attorney, City of Beaumont  
P.O. Box 3827  
Beaumont, Texas 77704-3827

Re: Lease between the City of Beaumont and Jefferson County  
Real Property to wit: Sarah and Warren Street, the South one-half of Block 19 in the M.C. Cartwright  
Subdivision in the J.W. Bullock League of the City of Beaumont

Dear Ms. Reed,

This should serve as the approval of the Commissioners Court of Jefferson County to Terminate the  
above-referenced lease, copy attached as Exhibit "A", upon approval by the City Council of Beaumont.  
Please note that acceptance by returning an executed copy of this letter for receipt and filing.

Sincerely yours,

Jeff R. Branick, County

Approval of the City of Beaumont:

Date: \_\_\_\_\_

\_\_\_\_\_  
Mayor, City of Beaumont



## City of Beaumont

February 9, 2022

Fred Jackson  
Jefferson County Judge's Office  
Jefferson County Courthouse  
1149 Pearl St.  
Beaumont, TX 77701

RE: Lease of Real Property to wit: Sarah Street and Warren Street (Being a portion of the South one-half (S1/2) of Block Nineteen (19) in the M.C. Cartwright Subdivision in the J.W. Bullock League of the City of Beaumont, Jefferson County, Texas)

Dear Mr. Jackson,

This letter serves as formal notice that the City of Beaumont would like to terminate its lease of the above referenced property immediately. The City is no longer the owner of the property at 3455 Sarah Street, and no longer has a public purpose for the leased property. I respectfully request that this matter be placed on the next Commissioner's Meeting Agenda for consideration.

I appreciate your prompt attention to this matter. Please contact me directly if you require any additional information.

Sincerely,

Sharae N. Reed  
City Attorney

SR/ss



EXHIBIT "A"

**L. L. MELTON PROPERTY LEASE AGREEMENT**

Date: May 21, 2013

Lessor: Jefferson County, Texas

Lessor's Physical Address: 1149 Pearl Street  
Beaumont, Texas 77701

Lessee: City of Beaumont, Texas

Lessee's Mailing Address: 801 Main Street  
Beaumont, Texas 77701

Leased Premises: Being a portion of the **South one-half (S. 1/2) of Block Nineteen (19)** in the M. C. Cartwright Subdivision in the J. W. Bullock League of the City of Beaumont, Jefferson County, Texas, and described by metes and bounds as follows:

BEGINNING at an iron pin in the west line of Block Nineteen (19), said iron pin marking the division line of the north and south one-half of Block Nineteen (19); said point being the northwest corner of the south one-half of Block Nineteen (19) and the southwest corner of the north one-half of Block Nineteen (19);

THENCE, East along the dividing line of the north and south one-half of Block Nineteen (19) a distance of **six hundred ninety-seven and five-tenths feet (697.5')** to an iron pin for corner, said iron pin being fifteen feet (15') west of the east line of Block Nineteen (19);

THENCE, South 0°8'30" west along a line fifteen feet (15') from and parallel to the east line of Block Nineteen (19) a distance of **three hundred five and sixty-five one hundredths feet (305.65')** to an iron pin for corner in the south line of Block Nineteen (19);

THENCE, West along the south line of Block Nineteen (19) a **distance of six hundred ninety-seven and five-tenths feet (697.5')** to an iron pin for corner, said iron pin being the southwest corner of Block Nineteen (19);

THENCE, North 0°8'30" east along the west line of Block Nineteen (19) a distance of **three hundred five and sixty-five one hundredths feet (305.65')** to the PLACE OF BEGINNING, said tract containing four and eighty-nine one hundredths (4.89) acres more or less.

Lease Commencement Date: This Agreement will commence upon execution by Lessor and Lessee.

Lease Term: The term of this lease is for a term of Twenty (20) years, beginning at the time of execution of this Lease.

**Lease Rent:** The total rent under this Lease is the sum of Twenty and No/100 (\$20.00) Dollars. LESSEE agrees to pay LESSOR said amount in annual installments of One and No/100 (\$1.00) Dollar each, beginning at the execution of this Lease, and payable on the 15<sup>th</sup> day of June of each year thereafter during the term of the Lease. LESSEE shall not be held in default for nonpayment of rent unless and until LESSOR give LESSEE ten (10) days notice in writing of said nonpayment.

**Permitted Lease Use:** Recreational, education, social, and civic activities.

1. Lessee agrees to lease the Leased Premises for the Lease Term beginning on the Lease Commencement Date and ending on the Lease Termination Date.
2. Lessee may sublet the lease premises, or any portion thereof, to an organization, public, private or not-for-profit, that will be used for the purpose of providing recreational, educational, social, and/or civic activities for the general public.
3. Lessee shall have no authority to incur any obligations on behalf of Lessor, and Lessor is not obligated to furnish Lessee any equipment or improvements beyond those agreed to by the parties.
4. Lease may be terminated by either the LESSOR or LESSEE for breach of any and all provisions herein.

**SIGNED:**

**LESSOR:**

Jefferson County, Texas

\_\_\_\_\_

\_\_\_\_\_  
Title

\_\_\_\_\_  
Date

**LESSEE:**

City of Beaumont, Texas

\_\_\_\_\_

\_\_\_\_\_  
Title

\_\_\_\_\_  
Date

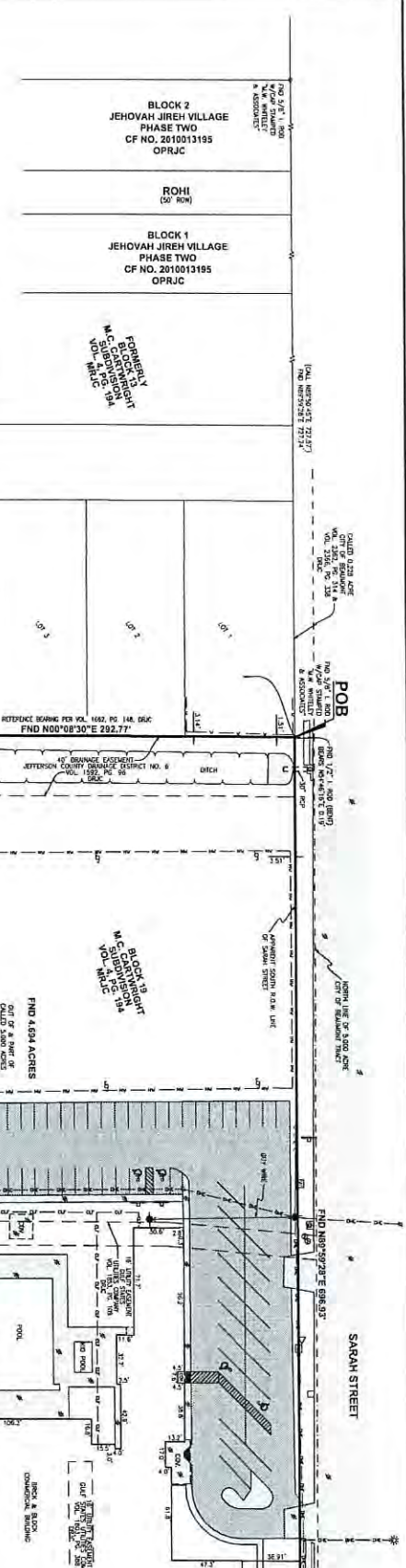

NO.	DATE	DESCRIPTION	BY	APP. BY
1	10/10/2011	PRELIMINARY PLAN	M.C. CONVIN	M.O. M.I.R.C.
2	10/10/2011	FINAL PLAN	M.C. CONVIN	M.O. M.I.R.C.

**NOTICE REGARDING THE SUBDIVISION OF LAND**

This subdivision is being recorded in accordance with the provisions of the Uniform Gifts to Minors Act (UGMA) and the Uniform Transfers to Minors Act (UTMA). The purpose of this subdivision is to transfer certain real property to the children of the donor, M.C. Convin, for their own use and enjoyment. The donor, M.C. Convin, is the father of the children named in this subdivision. The children are M.O. M.I.R.C., M.C. Convin, and M.O. M.I.R.C. The donor, M.C. Convin, is the father of the children named in this subdivision. The children are M.O. M.I.R.C., M.C. Convin, and M.O. M.I.R.C. The donor, M.C. Convin, is the father of the children named in this subdivision. The children are M.O. M.I.R.C., M.C. Convin, and M.O. M.I.R.C.

**LEGISLATIVE HISTORY**

The following bills have been introduced in the House of Representatives:

- H.R. 1234 - M.C. CONVIN
- H.R. 1235 - M.C. CONVIN
- H.R. 1236 - M.C. CONVIN
- H.R. 1237 - M.C. CONVIN
- H.R. 1238 - M.C. CONVIN
- H.R. 1239 - M.C. CONVIN
- H.R. 1240 - M.C. CONVIN
- H.R. 1241 - M.C. CONVIN
- H.R. 1242 - M.C. CONVIN
- H.R. 1243 - M.C. CONVIN
- H.R. 1244 - M.C. CONVIN
- H.R. 1245 - M.C. CONVIN
- H.R. 1246 - M.C. CONVIN
- H.R. 1247 - M.C. CONVIN
- H.R. 1248 - M.C. CONVIN
- H.R. 1249 - M.C. CONVIN
- H.R. 1250 - M.C. CONVIN

**COMMENTS**

This subdivision is being recorded in accordance with the provisions of the Uniform Gifts to Minors Act (UGMA) and the Uniform Transfers to Minors Act (UTMA). The purpose of this subdivision is to transfer certain real property to the children of the donor, M.C. Convin, for their own use and enjoyment. The donor, M.C. Convin, is the father of the children named in this subdivision. The children are M.O. M.I.R.C., M.C. Convin, and M.O. M.I.R.C. The donor, M.C. Convin, is the father of the children named in this subdivision. The children are M.O. M.I.R.C., M.C. Convin, and M.O. M.I.R.C. The donor, M.C. Convin, is the father of the children named in this subdivision. The children are M.O. M.I.R.C., M.C. Convin, and M.O. M.I.R.C.

**NOTICE TO THE PUBLIC**

THE STATE OF TEXAS, COUNTY OF DALLAS, TEXAS.

BEFORE ME, the undersigned authority, on this day personally appeared M.C. CONVIN, known to me to be the person whose name is subscribed to the foregoing instrument, and acknowledged to me that he executed the same for the purposes and consideration therein expressed.

Given under my hand and seal of office this 10th day of October, 2011.

\_\_\_\_\_  
 Notary Public in and for the State of Texas, My Commission Expires 10/10/2014

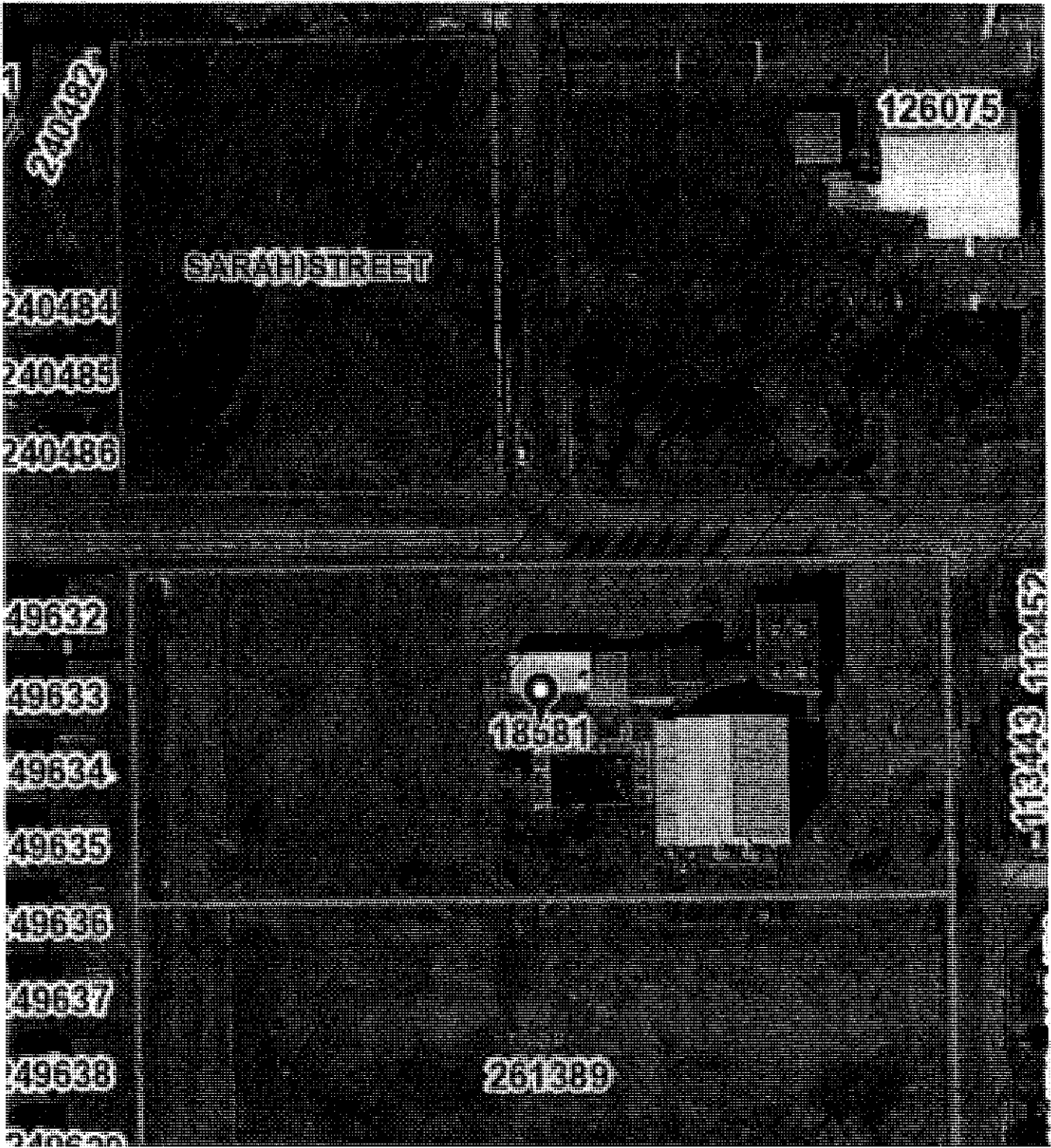

**Sharae N. Reed**  
 City Attorney  
 409.880.3715  
 409.880.3121 (fax)

Revised 1-21-15

**EMERGENCY GRANT REQUEST ADDENDUM  
OF JEFFERSON COUNTY  
HOTEL OCCUPANCY TAX (HOT) FUNDS**

Jefferson County Hotel Occupancy Tax funds are given as grants twice per year. These funds must be used to directly enhance the tourism and hotel industry in Jefferson County. The spring cycle applications are due the **first Friday in March** with the fall cycle applications due the **first Friday in September**. Press releases are sent out to the media and all former applicants at two week intervals starting eight weeks from the due date.

Emergency Request: A new tourism related event or project that was unknown prior to the last grant cycle.

**Please give written explanation as to why this is an emergency request. Attach this to the completed application when submitting.**

*To Whom It May Concern,*  
*The Beaverton Panthers first home game is scheduled for March 7, 2022. The emergency request for grant consideration is needed in order to begin promoting and advertising for the team. The team did not learn about grant availability until January 2022. Upon learning about the grants we immediately applied. Thank you in advance for your consideration.*

Revised 1-21-15

**ORIGINAL**

*Rec. 2-7-22 VR*

Revised 1-13-2022

**APPLICATION FOR USE OF JEFFERSON COUNTY  
HOTEL OCCUPANCY TAX FUNDS  
(FOR ADVERTISING AND PROMOTION FUNDING)**

Thank you for your interest in promoting tourism and the hotel industry in Jefferson County through the utilization of county Hotel Occupancy Tax (HOT) funds. The use is HOT funds is regulated by law (Tax code 352-1033), which limits the use of those funds for the direct enhancement and promotion of tourism AND the convention and hotel industry. **To determine eligibility, the following section of this tax code which pertains to advertising/promotion must apply to your application. "Advertise and conduct solicitations and promotional programs to attract tourists and conventions delegates or registrants to the county or its vicinity, any of which may be conducted by the county or through contracts with persons or organizations selected by the county.** In addition, a county that borders the Gulf of Mexico and that is authorized to impose the tax by Section 352.002(a)(6) may use 50% or less of the revenue from the tax for the promotion of tourism.

**I. CRITERIA**

**A. General Information**

1. Name of Organization  
The Beaumont Panthers

---

2. What specifically is being marketed or promoted? I.e. facility, event, etc.  
The Beaumont Panthers Basketball games, Ford Park, Local resteraunts and buisnesses, Local Hotels, City of Beaumont, Jefferson County
  
3. Total Amount of Funds Requested by this Grant? \$53,330.00
  
4. What is the organization's financial contribution for this project/event?  
The Beaumont Panthers has spent over \$460,000.000 to bring a professional team to Jefferson County.

Revised 1-13-2022

**ORIGINAL**

Rec. 1-18-22 VR

5. What other funding sources are being pursued or sought?

Current attempts for sponsorship from local buisnesses has been unsuccessfull.

6. Date of Event if applicable. Please ensure that you are requesting funds far enough in advance to be able to accomplish the goals for which you are requesting funds.

3/4, 3/5, 4/1, 4/2, 4/10, 4/27, 5/1, 5/7, 5/8, 5/14, 5/15, 5/22

Playoff

dates not included

7. Which hotel/s have you negotiated a special rate if this funding request is being used for an event? Please list hotel/s (do not list rates).

Holiday Inn  
MCM Elegante  
Avid Hotel

8. Completion date of project July 2022

**II. VISITOR IMPACT**

A. Provide numbers for the following:

1. Total visitors/participants: previous year N/A

expected this year 3500-5000

2. Visitors/participants who indicated they stayed or will stay in a Jefferson County hotel:

previous year N/A

expected this year 2000-3000

**III. FUNDING RECAP**

1. Provide a **specific line item description and amount** of exact use of funds being requested. Total should match amount being requested. (If more space is needed, please use attachments.)

<u>Amount</u>	<u>Line Item</u>
<u>\$9,500.00</u>	<u>Wrapping Team Travel Bus</u>
<u>\$2,500.00</u>	<u>Kendrick Instagram Advertising</u>
<u>\$5,000.00</u>	<u>Flyers and Poster</u>
<u>\$2,500.00</u>	<u>Web Advertising thebasketballleague.net</u>
<u>\$2,500.00</u>	<u>Boss Up Radio (30 sec slots) 1week</u>
<u>\$1,500.00</u>	<u>Pre Game Newspaper adds</u>
<u>\$1,500.00</u>	<u>Dedicated Uniform</u>
<u>\$3,000.00</u>	<u>30 day Billboard Advertising Baytown</u>
<u>\$9,415.00</u>	<u>Magic 102/ 119 slots/ 4 weeks</u>
<u>\$9,415.00</u>	<u>97.9 The Box/ 119 slots/ 4 weeks</u>
<u>\$6,500.00</u>	<u>Advertising Commercial Cost</u>
<u>\$53,330.00</u>	<u>TOTAL (Should match request on front page)</u>

**IV. MARKETING PLANS**

- A. How will your organization enhance the promotion of tourism AND the convention /hotel industry in Jefferson County?

Profesional basketball games that will host many retired NBA players and other celebrities that will stay at local hotels. In game commercials. Travel bus with with local hotel advertisement.



Revised 1-13-2022

B. What media will be used in your advertising and promotion? Please provide a detailed list of the media to be used, i.e. Houston Chronicle, KHOU, Southern Living, etc. (Must be outside 75-mile radius of Jefferson County)

In Game commercials that stream in over 100 countries. KPRC -TV Click 2 Houston, Social Media Platforms, Team Bus that will travel more than 4000 miles during the season to cities such as, Houston, Sugarland, Dallas, Waco, Shreveport, Enid, and more.

By signing this application, I, individually and on behalf of my organization, represent and agree that:

1. I have full authority to execute this application on behalf of myself, group, and organization;
2. Any funds allocated out of Hotel Occupancy Tax monies will be used solely in the manner set forth in the award letter;
3. I as a representative and my organization will, within 60 days following the date of my/our project/event, provide a complete and detailed accounting to the Jefferson County Tourism Commission, c/o Kathi Hughes, in such form as may be provided/requested;
4. Failure to provide the report within 60 days and/or to use the allocated monies solely for the purposes for which such funds were awarded shall render me and my group/organization liable for reimbursement to Jefferson County of all such funds, plus reasonable court costs and attorney fees.
5. Please submit a W-9 Form with application.

Date	January 14, 2022
Name of Organization	Representative Completing Form The Beaumont Panthers
Signature	 Verified by pdfFiller
Title	Owner 01/14/2022
Phone Number	832-754-8835
Federal Tax ID	86-3871767
Address	12902 Flat Creek Dr Pearland, Texas 77584
E-mail	jaymcdonald@thebeaumontpanthers.com
W-9 Attached	Attached

Revised 1-13-2022

Return Form to: Ben J. Rogers Regional Visitors Center  
Attn: Kathi Weathington Hughes  
5055 IH-10 South  
Beaumont, Texas 77705

Questions in regard to the application should be forwarded to Mrs. Kathi Hughes at 409-842-0500 or 866-432-8951.

**SPECIAL NOTE:** Grants of hotel occupancy tax revenues may statutorily be used only for the promotion of tourism. Expenditure of funds for unauthorized purposes may result in recapture and/or enter into funding decisions in future funding cycles.

**Request for Taxpayer  
Identification Number and Certification**

**Give Form to the  
requester. Do not  
send to the IRS.**

► Go to [www.irs.gov/FormW9](http://www.irs.gov/FormW9) for instructions and the latest information.

Print or type. See Specific Instructions on page 3.	<p><b>1</b> Name (as shown on your income tax return). Name is required on this line; do not leave this line blank. <b>The Beaumont Panthers LLC</b></p> <p><b>2</b> Business name/disregarded entity name, if different from above</p> <p><b>3</b> Check appropriate box for federal tax classification of the person whose name is entered on line 1. Check only <b>one</b> of the following seven boxes.</p> <p><input type="checkbox"/> Individual/sole proprietor or single-member LLC    <input type="checkbox"/> C Corporation    <input type="checkbox"/> S Corporation    <input type="checkbox"/> Partnership    <input type="checkbox"/> Trust/estate</p> <p><input checked="" type="checkbox"/> Limited liability company. Enter the tax classification (C=C corporation, S=S corporation, P=Partnership) ► <b>C</b></p> <p><b>Note:</b> Check the appropriate box in the line above for the tax classification of the single-member owner. Do not check LLC if the LLC is classified as a single-member LLC that is disregarded from the owner unless the owner of the LLC is another LLC that is <b>not</b> disregarded from the owner for U.S. federal tax purposes. Otherwise, a single-member LLC that is disregarded from the owner should check the appropriate box for the tax classification of its owner.</p> <p><input type="checkbox"/> Other (see instructions) ►</p>	<p><b>4</b> Exemptions (codes apply only to certain entities, not individuals; see instructions on page 3):</p> <p>Exempt payee code (if any) _____</p> <p>Exemption from FATCA reporting code (if any) _____</p> <p><small>(Applies to accounts maintained outside the U.S.)</small></p>
	<p><b>5</b> Address (number, street, and apt. or suite no.) See instructions. <b>12902 Flat Creek Dr</b></p> <p><b>6</b> City, state, and ZIP code <b>Pearland, Texas 77584</b></p> <p><b>7</b> List account number(s) here (optional)</p>	<p>Requester's name and address (optional)</p>

**Part I Taxpayer Identification Number (TIN)**

Enter your TIN in the appropriate box. The TIN provided must match the name given on line 1 to avoid backup withholding. For individuals, this is generally your social security number (SSN). However, for a resident alien, sole proprietor, or disregarded entity, see the instructions for Part I, later. For other entities, it is your employer identification number (EIN). If you do not have a number, see *How to get a TIN*, later.

**Note:** If the account is in more than one name, see the instructions for line 1. Also see *What Name and Number To Give the Requester* for guidelines on whose number to enter.

<b>Social security number</b>											
				-			-				
<b>OR</b>											
<b>Employer identification number</b>											
8	7										
				-	3 8 7 1		-	7 6 7			

**Part II Certification**

Under penalties of perjury, I certify that:

- The number shown on this form is my correct taxpayer identification number (or I am waiting for a number to be issued to me); and
- I am not subject to backup withholding because: (a) I am exempt from backup withholding, or (b) I have not been notified by the Internal Revenue Service (IRS) that I am subject to backup withholding as a result of a failure to report all interest or dividends, or (c) the IRS has notified me that I am no longer subject to backup withholding; and
- I am a U.S. citizen or other U.S. person (defined below); and
- The FATCA code(s) entered on this form (if any) indicating that I am exempt from FATCA reporting is correct.

**Certification instructions.** You must cross out item 2 above if you have been notified by the IRS that you are currently subject to backup withholding because you have failed to report all interest and dividends on your tax return. For real estate transactions, item 2 does not apply. For mortgage interest paid, acquisition or abandonment of secured property, cancellation of debt, contributions to an individual retirement arrangement (IRA), and generally, payments other than interest and dividends, you are not required to sign the certification, but you must provide your correct TIN. See the instructions for Part II, later.

<b>Sign Here</b>	Signature of U.S. person ►	Date ►
------------------	----------------------------	--------

**General Instructions**

Section references are to the Internal Revenue Code unless otherwise noted.

**Future developments.** For the latest information about developments related to Form W-9 and its instructions, such as legislation enacted after they were published, go to [www.irs.gov/FormW9](http://www.irs.gov/FormW9).

**Purpose of Form**

An individual or entity (Form W-9 requester) who is required to file an information return with the IRS must obtain your correct taxpayer identification number (TIN) which may be your social security number (SSN), individual taxpayer identification number (ITIN), adoption taxpayer identification number (ATIN), or employer identification number (EIN), to report on an information return the amount paid to you, or other amount reportable on an information return. Examples of information returns include, but are not limited to, the following.

- Form 1099-INT (interest earned or paid)

- Form 1099-DIV (dividends, including those from stocks or mutual funds)
- Form 1099-MISC (various types of income, prizes, awards, or gross proceeds)
- Form 1099-B (stock or mutual fund sales and certain other transactions by brokers)
- Form 1099-S (proceeds from real estate transactions)
- Form 1099-K (merchant card and third party network transactions)
- Form 1098 (home mortgage interest), 1098-E (student loan interest), 1098-T (tuition)
- Form 1099-C (canceled debt)
- Form 1099-A (acquisition or abandonment of secured property)

Use Form W-9 only if you are a U.S. person (including a resident alien), to provide your correct TIN.

*If you do not return Form W-9 to the requester with a TIN, you might be subject to backup withholding. See What is backup withholding, later.*

**vrhodes@co.jefferson.tx.us**

---

**Subject:** FW: Questions about Spring 2022 Grant App.  
**Attachments:** image002.jpg; image004.jpg; image006.jpg; Screenshot\_20220118-142036\_Gmail.jpg

**From:** Beaumont Panthers <jaymcdonald@thebeaumontpanthers.com>  
**Sent:** Tuesday, January 18, 2022 2:25 PM  
**To:** vrhodes@co.jefferson.tx.us  
**Cc:** Kathi <khughes@co.jefferson.tx.us>  
**Subject:** Re: Questions about Spring 2022 Grant App.

Hello and thank you for getting back to me.

1. Where will the basketball games take place? Ford Park.
2. What Social Media Advertising will you use? Can you give us an example? Kendrick Perkins has over 200k IG followers. He will be one form of advertising. Also the league and players from each team will promote the up coming games in the city. They will also post their trip to Beaumont.
3. Where will the flyers and posters be distributed? Flyers and posters will be posted all over social media as well as throughout the city of the visiting team. We do this to encourage people who can't attend the games to watch the games from the streaming platform.
4. What websites do you plan on using for advertising?  
thebeaumontpanthers.com thebasketballleague.net
5. Which radio group do you plan on using, and where do they broadcast? Kendrick has a national podcast with ESPN that we will advertise on as well as 104.5 FM.
6. Which newspaper do you plan on using, and where are they located? Beaumont Enterprise, Sugar Land Sun as well as each teams local paper.
7. What is uniform placement? We will have special uniforms that highlight the city of Beaumont. (See attachment)
8. Also, the address you have listed for the Beaumont Panther's W-9 and grant application is Ford Park's address. Are you currently housed at Ford Park? No, Ford Park is where we will be playing our games and will have an office there during the season for the next 3 years.

The Beaumont Panthers will be a great addition to the city. It will bring tourists from cities as far as states as far as Oklahoma and Omaha while providing great opportunities for local youth.

On Tue, Jan 18, 2022, 2:03 PM <vrhodes@co.jefferson.tx.us> wrote:

Good afternoon, my name is Victoria Rhodes and I handle the HOT Tax Grant Applications. It's a pleasure to meet you. Also, thank you for turning in your grant application so early! It's very much appreciated.

There are some questions that the group will ask so I just wanted to get some additional information. Just a reminder, all advertising must be outside of 75+ miles to be eligible. If it's local, it will not be approved.

The most important question though is the grant meant to be an emergency grant? When did you know this tournament would take place/when did you sign with the location hosting your tournaments?

1. Where will the basketball games take place?
2. What Social Media Advertising will you use? Can you give us an example?
3. Where will the flyers and posters be distributed?
4. What websites do you plan on using for advertising?
5. Which radio group do you plan on using, and where do they broadcast?
6. Which newspaper do you plan on using, and where are they located?
7. What is uniform placement?
8. Also, the address you have listed for the Beaumont Panther's W-9 and grant application is Ford Park's address. Are you currently housed at Ford Park?

If you plan on using more than one newspaper, radio group, website, etc. please list out each specific company and the cost per each one. The grants have to be very specific so we need all of this additional information.

Thank you,

*Victoria Rhodes*

Hotel Occupancy Tax Grant Coordinator

Ben J. Rogers Regional Visitors Center

5055 IH-10 South, Beaumont, Tx. 77705

Office: 409-842-0500

Direct Line: 409-434-5447

Fax: 409-842-0501

**vrhodes@co.jefferson.tx.us**

---

**From:** Beaumont Panthers <jaymcdonald@thebeaumontpanthers.com>  
**Sent:** Thursday, January 20, 2022 12:40 AM  
**To:** vrhodes@co.jefferson.tx.us  
**Subject:** Re: Questions about Spring 2022 Grant App.

Hello Victoria,

*There is something that I forgot to mention. The League would like for us to host All Star Weekend which means we will have upwards of 3000-5000 people here in one weekend. There is also another group from Puerto Rico that reached out to after seeing a post that Kendrick made on his instagram and they would like to host a Professional Skills Tournament at Ford Park which would bring even more visitors to the area. I will send an updated form if you would like with all this information.*

On Wed, Jan 19, 2022 at 4:25 PM Beaumont Panthers <jaymcdonald@thebeaumontpanthers.com> wrote:  
You are welcome.

On Wed, Jan 19, 2022 at 4:19 PM <vrhodes@co.jefferson.tx.us> wrote:

Thank you so much!

*Victoria Rhodes*

Hotel Occupancy Tax Grant Coordinator

Ben J. Rogers Regional Visitors Center

5055 IH-10 South, Beaumont, Tx. 77705

Office: 409-842-0500

Direct Line: 409-434-5447

Fax: 409-842-0501

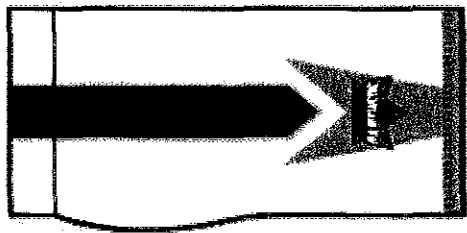
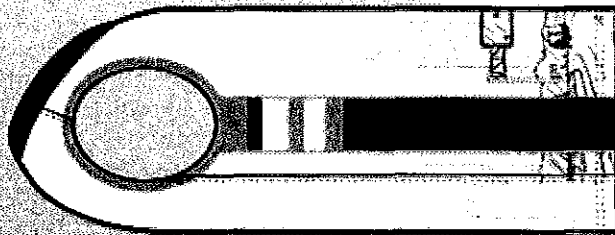
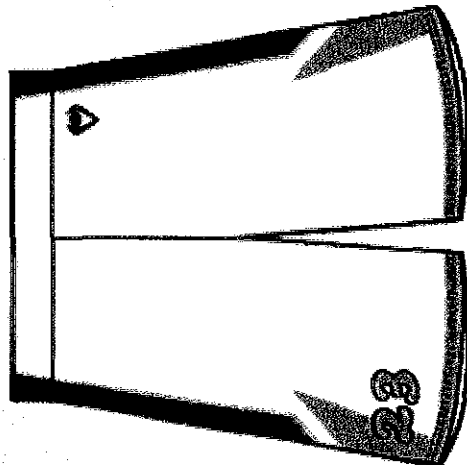
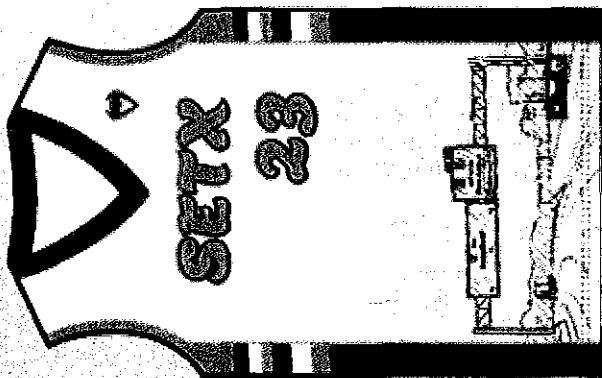
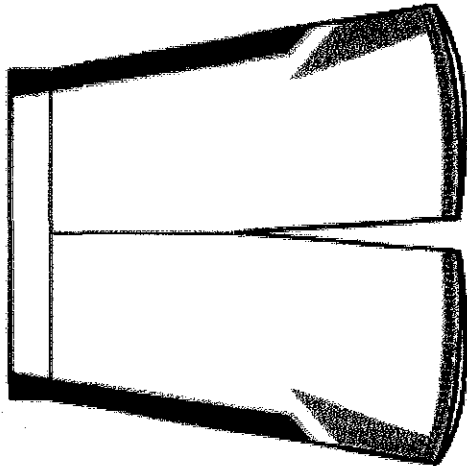
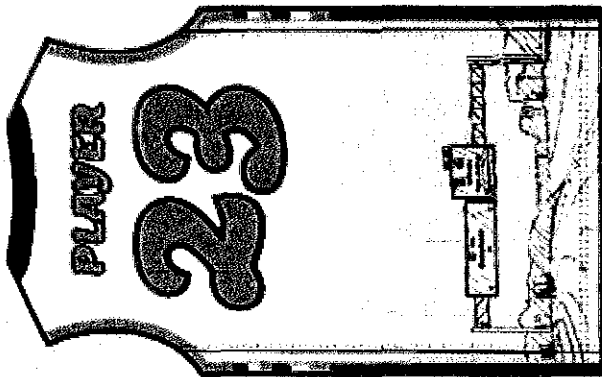
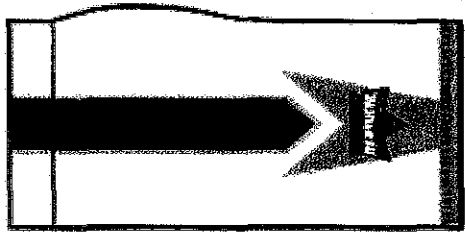
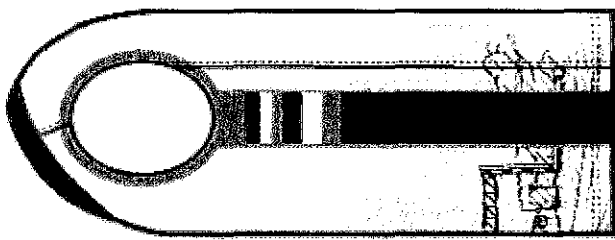

AWAY

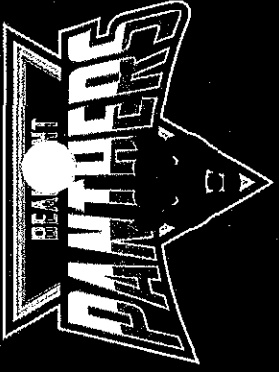

HOME

# BACK TO BACK

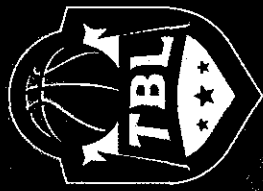

2022 SEASON SCHEDULE

3/7	3/10	3/12	3/13	3/18	3/19	4/23	4/27	4/30	5/1	5/7	5/20	5/22	5/28	5/29
AT PITTSBURGH	AT PITTSBURGH	AT PITTSBURGH	AT PITTSBURGH	AT PITTSBURGH	AT PITTSBURGH	AT PITTSBURGH	AT PITTSBURGH	AT PITTSBURGH	AT PITTSBURGH	AT PITTSBURGH	AT PITTSBURGH	AT PITTSBURGH	AT PITTSBURGH	AT PITTSBURGH
AT PITTSBURGH	AT PITTSBURGH	AT PITTSBURGH	AT PITTSBURGH	AT PITTSBURGH	AT PITTSBURGH	AT PITTSBURGH	AT PITTSBURGH	AT PITTSBURGH	AT PITTSBURGH	AT PITTSBURGH	AT PITTSBURGH	AT PITTSBURGH	AT PITTSBURGH	AT PITTSBURGH
AT PITTSBURGH	AT PITTSBURGH	AT PITTSBURGH	AT PITTSBURGH	AT PITTSBURGH	AT PITTSBURGH	AT PITTSBURGH	AT PITTSBURGH	AT PITTSBURGH	AT PITTSBURGH	AT PITTSBURGH	AT PITTSBURGH	AT PITTSBURGH	AT PITTSBURGH	AT PITTSBURGH
AT PITTSBURGH	AT PITTSBURGH	AT PITTSBURGH	AT PITTSBURGH	AT PITTSBURGH	AT PITTSBURGH	AT PITTSBURGH	AT PITTSBURGH	AT PITTSBURGH	AT PITTSBURGH	AT PITTSBURGH	AT PITTSBURGH	AT PITTSBURGH	AT PITTSBURGH	AT PITTSBURGH
AT PITTSBURGH	AT PITTSBURGH	AT PITTSBURGH	AT PITTSBURGH	AT PITTSBURGH	AT PITTSBURGH	AT PITTSBURGH	AT PITTSBURGH	AT PITTSBURGH	AT PITTSBURGH	AT PITTSBURGH	AT PITTSBURGH	AT PITTSBURGH	AT PITTSBURGH	AT PITTSBURGH

WWW.THEBEAUMONTPANthers.COM



# THE BEAUMONT PANTHERS



From: Loren Gross  
 Phone: (713) 300-5876  
 Email: lgross@radio-one.com

**Schedule Grand Totals: 4 Weeks**

Stations	Spots	Unit Rate	Total Cost
<b>Radio Total</b>	<b>238</b>	<b>\$79.12</b>	<b>\$18,830.00</b>
<b>KBOX-FM</b>	<b>119</b>	<b>\$79.12</b>	<b>\$9,415.00</b>
<b>KMLQ-FM</b>	<b>119</b>	<b>\$79.12</b>	<b>\$9,415.00</b>

Accepted by Station

Date

Accepted by Client

Date

This station does not discriminate in the sale of advertising time and will accept no advertising which is placed with an intent to discriminate on the basis of race, gender or ethnicity. Advertiser hereby certifies that it is not buying broadcasting air time under this advertising sales contract for a discriminatory purpose, including but not limited to decisions not to place advertising on particular stations on the basis of race, gender, national origin or ancestry.

The first demo listed is the Primary Demo.

This report was created in TAPSCAN using the following Radio information: HOUSTON-GALVESTON:

The Nielsen Company. All rights reserved.

Metro; Multiple Dayparts Used; P 25-54; See Detailed Sourcing Page for Complete Details.



**Brothers Forever Productions**

9898 Blissonnet St Ste 470  
Houston, TX 77036 US  
brothersforever82@gmail.com



**INVOICE**

**BILL TO**  
Mr Kendrick Perkins  
The Beaumont Panthers LLC

**INVOICE** 09892  
**DATE** 01/06/2022  
**TERMS** Due on receipt  
**DUE DATE** 02/15/2022

SERVICE	DESCRIPTION	QTY	RATE	AMOUNT
4k/ 10 bit Filming Service	Includes: 4K video service 10 Bit Rec Quality Editing Services Color Corrections 2 Revisions Promotional video	1	7,500.00	7,500.00
Travel	Travel outside of Houston City Limits.	1	200.00	200.00
<b>BALANCE DUE</b>				<b>\$7,700.00</b>

## Detailed Sourcing Summary

Radio Market: HOUSTON-GALVESTON  
 Survey: Nielsen Radio  
 Geography: Metro  
 Daypart: Multiple Dayparts Used

### Demo/Intab/Population:

Age/Gender	Population		Intab	
	Avg Daily	Avg Weekly	Avg Daily	Avg Weekly
Adults 25-54 (Primary)	2,989,400	2,994,500	881	743

Stations: User Selected  
 Additional  
 Notices:

Estimates reported for dayparts which start and end between 12m and 5a are based on the 5a-5a broadcast day. Estimates for all other dayparts are based on the 12m-12m calendar day.

Stations qualify to be reported if they have received credit for five or more minutes of listening and meet a minimum reporting standard of 0.1 AQH unrounded rating in the Metro survey area, Monday-Sunday 6AM-Midnight, during the survey period. If a current Nielsen client does not meet this minimum reporting standard, Nielsen will report the station as long as credited listening is received from at least one panelist.

PPM estimates are derived from the PPM technology and methodology and are subject to the qualifications and limitations stated in that Report. The TAPSCAN Web software product is accredited by the Media Rating Council and reports both accredited and non-accredited data. For a list of the accredited and non-accredited Nielsen radio markets and data available through TAPSCAN, click here: [http://www.arbitron.com/downloads/MRC\\_Accredited\\_Services\\_Markets.pdf](http://www.arbitron.com/downloads/MRC_Accredited_Services_Markets.pdf)

The Reach and Frequency Model utilized by Nielsen is formulated on the bases of the Harris Model, a Linear Frequency reach-and-frequency model, and the Slide Rule audience (cume) growth model.

Ascription Website: <http://ascription.nielsen.com>  
 Rating Reliability Estimator: <https://rrr.nielsen.com>

A Nielsen Radio eBook Special Notices and Station Activities document has been generated for each survey. Please select the hyperlink to the survey that interests you.  
<https://ebook.nielsen.com/secure/PPS/2019APR0033/pdfs/SpecialNotices.pdf>

Report: Copyright 2008 Nielsen. Software: Copyright 2008-2019 Nielsen. Nielsen Radio Data: Copyright 2019 Nielsen. All rights reserved. For use pursuant to a license from The Nielsen Company. Subject to the limitations and qualifications disclosed in the data and reports.

TAPSCAN is a mark of TAPSCAN Inc. used under license. Nielsen and the Nielsen logo are trademarks or registered trademarks of C2T/ACN Trademarks, L.L.C.

The Nielsen Company. All rights reserved.

nielsen  
 . . . . .

**vrhodes@co.jefferson.tx.us**

---

**From:** Kathi Hughes <khughes@co.jefferson.tx.us>  
**Sent:** Tuesday, January 25, 2022 1:18 PM  
**To:** vrhodes@co.jefferson.tx.us  
**Subject:** FW: MCM ELEGANTE' BEAUMONT - THE BEAUMONT PANTHERS ROOM BLOCK - PRINT SCREEN

Tori,  
Please put this email with the Panther's application. It shows their blocks and host hotel. The number of rooms for visiting teams may change. She does not have official room dates needed.  
Thanks,  
Kathi

**Kathi Weathington Hughes, Director**  
Ben J. Rogers Regional Visitors Center, Jefferson County  
5055 IH-10 South  
Beaumont, TX 77705  
Office 409/842-0500  
Cellular 409/679-2808  
Fax 409/842-0501

*Welcoming the World to Southeast Texas!*



**From:** modestyhawthorne@mcmelegante.com <modestyhawthorne@mcmelegante.com>  
**Sent:** Tuesday, January 25, 2022 1:00 PM  
**To:** khughes@co.jefferson.tx.us  
**Subject:** MCM ELEGANTE' BEAUMONT - THE BEAUMONT PANTHERS ROOM BLOCK - PRINT SCREEN

**ORIGINAL**

Rec. 1-25-22 VR

Booking By Client Code [mhawthor] - MCM Elegante Beaumont

Home End Page Up Prev

Search (F3) Save/Exit (F4) Esc (Shift+F4) Drill Down (F5)

File Record Window Help

Client Code: 2004910  
 Client Name: 04-The Beaumont Panthers

Booking#	Description	Start Date	End Date
124553	Homefront Fire	04/21/2022	04/23/2022
124551	Waco Royals	04/14/2022	04/16/2022
124550	Shreveport Mavericks	04/13/2022	04/15/2022
124549	Waco Royals	04/07/2022	04/09/2022
124548	Sugar Land Imperials	04/06/2022	04/08/2022
124528	Waco Royals	04/30/2022	05/02/2022
124524	Shreveport Mavericks	04/26/2022	04/28/2022
124523	Dallas Skyline	04/09/2022	04/11/2022
124522	Sugar Land Imperials	04/01/2022	04/03/2022
124521	Dallas Skyline	03/31/2022	04/02/2022
124520	Erld Outlaws	03/08/2022	03/10/2022
124519	Sugar Land Imperials	03/06/2022	03/08/2022
124517	The Beaumont Panthers - Home T	02/01/2022	02/01/2022

Hi Kathy, the print screen is pasted above.

The room quantities may change for visiting teams but Mr. McDonald mentioned a possibility of 15-20 rooms for visiting.

Please, let me know if you will need anything else.

[Working in Beaumont? Click here to see how we can help you!](#)

Kind Regards,

*Modesty Hawthorne* | Sales Manager

MCM Elegante' Hotel & Conference Center

Direct Line: 409-617-0603

Mobile: 409-225-4531

Main Line: 409-842-3600- ext.603

Fax: 409-842-0023

Click below to view pictures of our property.



Booking By Client Code [mhawthor] - MCM Elegante Beaumont

Home End Page Up Prev Row Next Row P  
 Search (F3) Save/Exit (F4) Esc (Shift+F4) Drill Down (F5) Create (F6) Delete (F7)

File Record Window Help

Client Code: 2004910  
 Client Name: 04-The Beaumont Panthers

Status to Show  
 All  
 Pending  
 Confirmed

Booking#	Description	Start Date	End Date	St	Account#	Am. no	GRM Revenue
124553	Redwolves Fire	05/21/2022	05/23/2022	TR	MHAWTHOR	20	1980.00
124554	Waco Royals	05/14/2022	05/16/2022	TR	MHAWTHOR	20	1980.00
124550	Shenepost Mavericks	05/11/2022	05/13/2022	TR	MHAWTHOR	20	1980.00
124549	Waco Royals	05/07/2022	05/09/2022	TR	MHAWTHOR	20	1980.00
124548	Sugar Land Impenals	05/06/2022	05/06/2022	TR	MHAWTHOR	20	1980.00
124529	Waco Royals	04/30/2022	05/02/2022	TR	MHAWTHOR	20	1980.00
124524	Shenepost Mavericks	04/28/2022	04/28/2022	TR	MHAWTHOR	20	1980.00
124523	Dallas Skyline	04/09/2022	04/11/2022	TR	MHAWTHOR	20	1980.00
124522	Sugar Land Impenals	04/01/2022	04/05/2022	TR	MHAWTHOR	20	1980.00
124521	Dallas Skyline	03/31/2022	04/01/2022	TR	MHAWTHOR	20	1980.00
124520	End Outans	03/08/2022	03/10/2022	TR	MHAWTHOR	20	1980.00
124519	Sugar Land Impenals	03/06/2022	03/06/2022	TR	MHAWTHOR	20	1980.00
124517	The Beaumont Panthers - Home T	02/01/2022	02/21/2022	OF	MHAWTHOR	833	17477.00

ALLISON NATHAN GETZ  
TAX ASSESSOR-COLLECTOR



TERRY WUENSCHERL  
CHIEF DEPUTY

**Tax Refund Determination**

Taxpayer name: First Liberty National Bank  
Address: P. O. Box 10109, Liberty, TX 77575  
Account Number: 053500-000/007400-00000  
Amount of Refund: \$5,880.69

Upon review, by the Tax Office and Auditor's department, both agreed for placement of an agenda item on the Commissioners' Court agenda for approval as required by Tax Code Section 31.11.

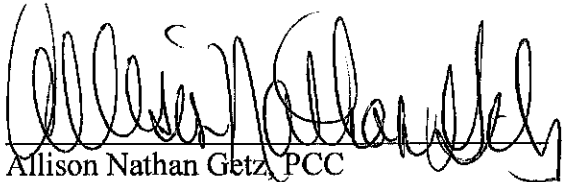
  
Allison Nathan Getz, PCC  
Tax Assessor-Collector  
Jefferson County

02/07/22  
Date

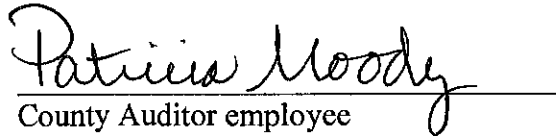
  
County Auditor employee

2/7/22  
Date

DUPLICATE TAX RECEIPT



ALLISON NATHAN GETZ, P.C.C.
JEFFERSON COUNTY TAX ASSESSOR - COLLECTOR
P.O. BOX 2112, BEAUMONT, TX 77704
EMAIL: PROPERTY@CO.JEFFERSON.TX.US
(409) 835-8516, WEBSITE: WWW.JEFFCOTAX.COM

Certified Owner:

DERRICK PARKER
DERRICK VICTORIA ALLEMAN
111 MAPLE STREET
PORT NECHES, TX 77651-3139

Legal Description:

TR 5-A REPLAT LT 5 S1/2 & ALL LTS 6 7 &
8 BLK 8 PORT NECHES .2602AC

Parcel Address: 111 MAPLE ST
Legal Acres: 0.2602

Deposit No: M0122202216A
Validation No: 900000061914537
Account No: 053500-000/007400-00000
Operator Code: TERRYW

Remit Seq No: 49265113
Receipt Date: 01/18/2022
Deposit Date: 01/18/2022
Print Date: 01/26/2022

Table with 8 columns: Year, Tax Unit Name, Tax Value, Tax Rate Per/100, Levy Paid, P&I, Coll Fee Paid, Total. Rows include Jefferson County, Pt Neches-Groves Isd, City Of Port Neches, Drainage District #7, Sabine-Neches Nav. Dist., and Overpay.

Check Number(s):
502678

PAYMENT TYPE:

Checks: \$12,430.21

Exemptions on this property:

HOMESTEAD

Total Applied: \$12,430.21

Change Paid: \$0.00

ACCOUNT PAID IN FULL

PAYER:
FIRST LIBERTY NATIONAL BANK
PO BOX 10109
LIBERTY, TX 77575



THIS DOCUMENT HAS A WATERMARK, ORIGINAL DOCUMENT SECURITY SCREEN AND A THERMOCHROMIC ICON; ABSENCE OF THESE FEATURES WILL INDICATE A COPY



**First  
Liberty  
National  
Bank**

# CASHIER'S CHECK

502678

88-1805  
1131

009350 - 000/035700 - 00000 etc

DATE 12/29/2021

P.O. Box 10109 Liberty TX 77575

REMITTER FIRST LIBERTY NATIONAL BANK

**\*\*\*\*\*50,702.64**

TWO SIGNATURES REQUIRED OVER \$50,000.00

PAY Fifty Thousand Seven Hundred Two Dollars AND 64/100

TO THE ORDER OF JEFFERSON COUNTY TAX A/C  
P O BOX 2112  
BEAUMONT, TX 77704

*Emily Palmer*  
*[Signature]*

AUTHORIZED SIGNATURE

PURPOSE 007800 - 000/001500-00000 etc

02/07/2022 09:54:41  
 TN536 SELECTION SEQUENCE 3943633  
 HELD OVERPAYMENT REFUNDS  
 REFUNDS REPORTED FOR INSPECTION ONLY

TAX COLLECTION SYSTEM  
 REFUNDS SELECTED REPORT  
 FROM: 01/18/2022 TO: 01/18/2022

PAGE: 1

MINIMUM DOLLAR AMOUNT: \$2500

ACCOUNT NUMBER	UNP TOT YEAR UNIT	APPR DIST #	OWNER NAME	SUIT REC TYPE	DEPOSIT RECEIPT DATE	REMITTANCE# STAT	AMOUNT	REFUND REASON(S)
053500-000/007400-00000		93845	2021 8001 DERRICK PARKER	TL	M0122202216A 20220118	49265113 PA	5,880.69	
CHECK PAYEE: FIRST LIBERTY NATIONAL BANK				TR 5-A REPLAT LT 5 S1/2 & ALL LTS		CHECK TOTAL:	5,880.69	
PO BOX 10109				8 BLK 8 PORT NECHES .2602AC				
LIBERTY TX77575								

FIDO # : 26791216

TOTAL AMOUNT DUE FOR ACCOUNT .00

TOTAL ALL ACCOUNTS

5,880.69

COUNT OF REFUND CHECKS

1

ALLISON NATHAN GETZ  
TAX ASSESSOR-COLLECTOR



TERRY WUENSCHERL  
CHIEF DEPUTY

**Tax Refund Determination**

Taxpayer name: Delaware and Dowlen Group  
Address: 1277 Calder Ave, Beaumont, TX 77701  
Account Number: 008901-000/004200-00000  
Amount of Refund: \$8,873.56

Upon review, by the Tax Office and Auditor's department, both agreed for placement of an agenda item on the Commissioners' Court agenda for approval as required by Tax Code Section 31.11.

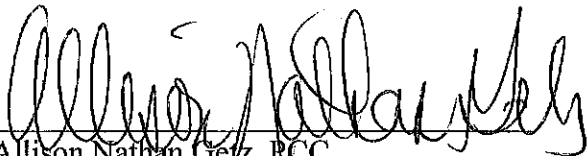
  
Allison Nathan Getz, RCC  
Tax Assessor-Collector  
Jefferson County

02/07/22  
Date

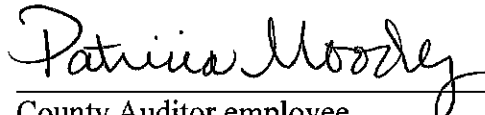
  
County Auditor employee

2/7/22  
Date

DUPLICATE TAX RECEIPT



ALLISON NATHAN GETZ, P.C.C.
JEFFERSON COUNTY TAX ASSESSOR - COLLECTOR
P.O. BOX 2112, BEAUMONT, TX 77704
EMAIL: PROPERTY@CO.JEFFERSON.TX.US
(409) 835-8516, WEBSITE: WWW.JEFFCOTAX.COM

Certified Owner:

DELAWARE & DOWLEN GROUP LLC
1277 CALDER AVE
BEAUMONT, TX 77701-1704

Legal Description:

CALDER HIGHLANDS ADD LOTS 1-2 BLK 9
.5127AC

Parcel Address: 4190 GLADYS AVE
Legal Acres: 0.5126

Deposit No: B0124202216A
Validation No: 900000062003776
Account No: 008901-000/004200-00000
Operator Code: TERRYW

Remit Seq No: 49457682
Receipt Date: 01/24/2022
Deposit Date: 01/24/2022
Print Date: 02/07/2022

Table with 7 columns: Year, Tax Unit Name, Tax Value, Tax Rate Per/100, Levy Paid, P&I, Coll Fee Paid, Total. Rows include Jefferson County, Beaumont Isd, City Of Beaumont, Port Of Beaumont, Drainage District #6, Sabine-Neches Nav. Dist., and Overpay.

Check Number(s):
2429

PAYMENT TYPE:
Checks: \$23,140.58

Exemptions on this property:

Total Applied: \$23,140.58
Change Paid: \$0.00
ACCOUNT PAID IN FULL

PAYER:
DELAWARE AND DOWLEN GROUP
1277 CALDER AVE
BEAUMONT, TX 77701

**DELAWARE AND DOWLEN GROUP**  
1277 CALDER AVENUE  
BEAUMONT, TX 77701

*Bo124 202216A*

2429

35-9414/1130  
05

*Ret.*

DATE 12/1/2021

CHECK ARMOR

PAY TO THE ORDER OF Allison Nathan Getz

\$ 122,936.45

One hundred twenty two thousand nine hundred thirty six and <sup>45</sup>/<sub>100</sub>---  
DOLLARS

Photo Safe Deposit®  
Death on Demand



www.thirdcoastbank.com

FOR 14228 etz (12)

*[Signature]*



02/07/2022 10:44:42

TN536

SELECTION SEQUENCE 3943802  
 HELD OVERPAYMENT REFUNDS  
 REFUNDS REPORTED FOR INSPECTION ONLY

TAX COLLECTION SYSTEM  
 REFUNDS SELECTED REPORT  
 FROM: 01/24/2022 TO: 01/24/2022

PAGE: 1

MINIMUM DOLLAR AMOUNT: \$2500

ACCOUNT NUMBER	UNP	TOT	YEAR	UNIT	OWNER NAME	APPR DIST #	SUIT REC TYPE	DEPOSIT RECEIPT	DATE	REMITTANCE#	STAT	AMOUNT	REFUND REASON(S)
008901-000/004200-00000					2021 8001 DELAWARE & DOWLEN GROUP LLC	14228	TL	B0124202216A	20220124	49457682	PA	8,873.56	
CHECK PAYEE: DELAWARE AND DOWLEN GROUP													
1277 CALDER AVE													
BEAUMONT TX77701													
CALDER HIGHLANDS ADD LOTS 1-2 BLK CHECK TOTAL: 8,873.56													
.5127AC													

FIDO # : 22311888

TOTAL AMOUNT DUE FOR ACCOUNT .00

TOTAL ALL ACCOUNTS

8,873.56

COUNT OF REFUND CHECKS

1

**INDEX OF SHEETS**

SHT NO.	DESCRIPTION
1	TITLE SHEET
2	PLAN-HEBERT ROAD
3	ENLARGED PLAN-HEBERT ROAD
4	SECTIONS
5	GENERAL NOTES

# JEFFERSON COUNTY ENGINEERING DEPARTMENT

## PLANS OF PROPOSED HEBERT ROAD CULVERTS REPLACEMENT

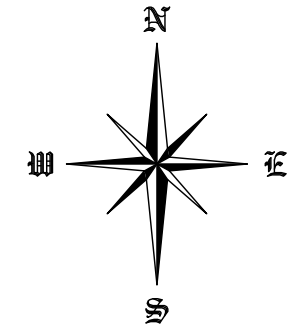

SCALE: NTS

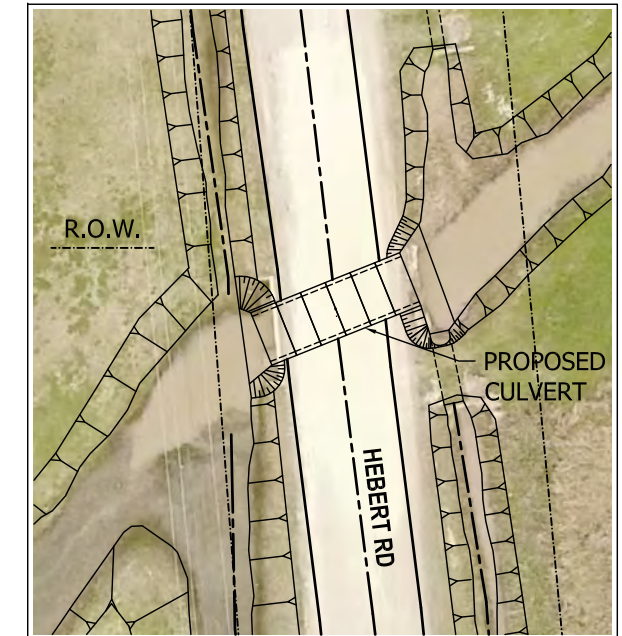

**ENLARGED PLAN  
(HEBERT ROAD)**

*M. H. Falgout*  
 STATE OF TEXAS  
 M. H. FALGOUT  
 73458  
 LICENSED PROFESSIONAL ENGINEER  
 12-10-21

JEFFERSON COUNTY ENGINEERING DEPARTMENT JEFFERSON COUNTY COURTHOUSE 1149 PEARL STREET, 5TH FLOOR BEAUMONT, TEXAS 77701 <small>PHONE: (409) 835-8584 FAX: (409) 835-8718</small>	
PROJECT: HEBERT ROAD CULVERTS REPLACEMENT	
SHEET 1 OF 5	SHEET
DRW'N. BY: G.K.	01
CHK'D. BY: M.F.	

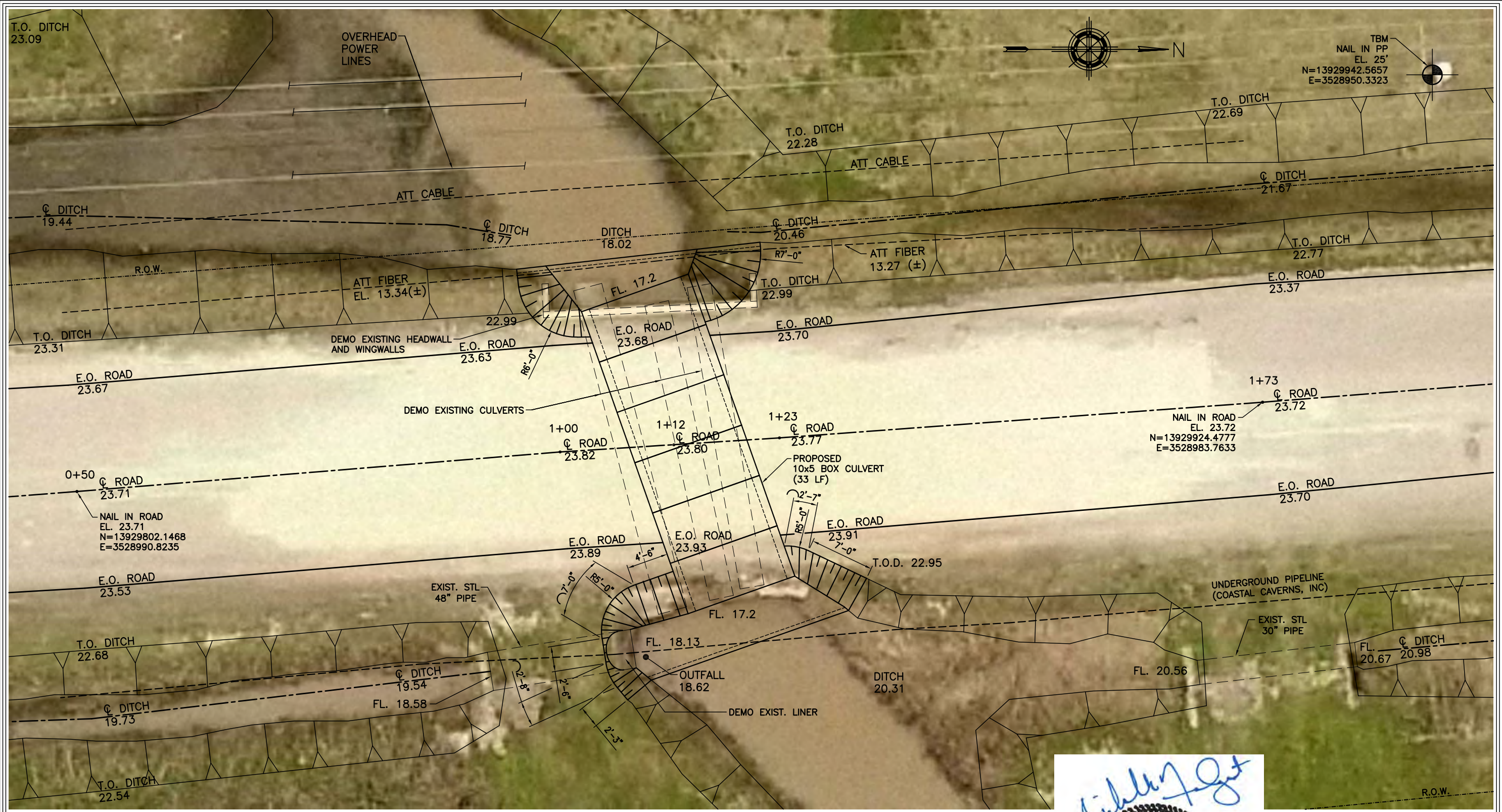

NOTES: ASSUMED DATUM

PLAN-HEBERT ROAD  
 SCALE: 1"=10'

*M. H. Falgout*  
 STATE OF TEXAS  
 M. H. FALGOUT  
 73458  
 LICENSED PROFESSIONAL ENGINEER  
 12-10-21

JEFFERSON COUNTY ENGINEERING DEPARTMENT JEFFERSON COUNTY COURTHOUSE 1149 PEARL STREET, 5TH FLOOR BEAUMONT, TEXAS 77701 PHONE: (409) 835-8584 FAX: (409) 835-8718	
PROJECT: HEBERT ROAD CULVERTS REPLACEMENT	
SHEET 2 OF 5 DRW'N. BY: G.K. CHK'D. BY: M.F.	SHEET 02





NOTE: DRAWN TO ALLOW FOR 2" GAP IN BETWEEN BOXES.

ENLARGED PLAN-HEBERT ROAD  
SCALE: 1"=5'-0"



JEFFERSON COUNTY ENGINEERING DEPARTMENT JEFFERSON COUNTY COURTHOUSE 1149 PEARL STREET, 5TH FLOOR BEAUMONT, TEXAS 77701 PHONE: (409) 835-8584 FAX: (409) 835-8718	
PROJECT: HEBERT ROAD CULVERTS REPLACEMENT	
SHEET 3 OF 5 DRW'N. BY: G.K. CHK'D. BY: M.F.	SHEET  03

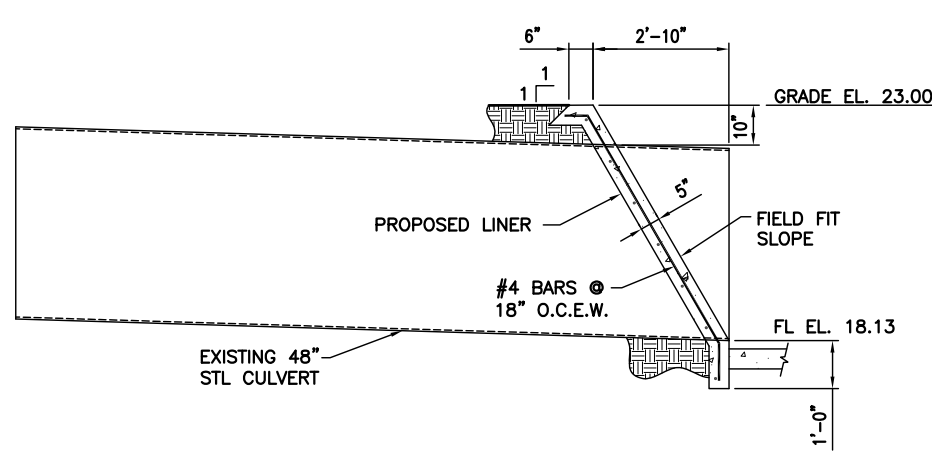

**A** SECTION  
S3 SCALE: 1/4"=1'-0"

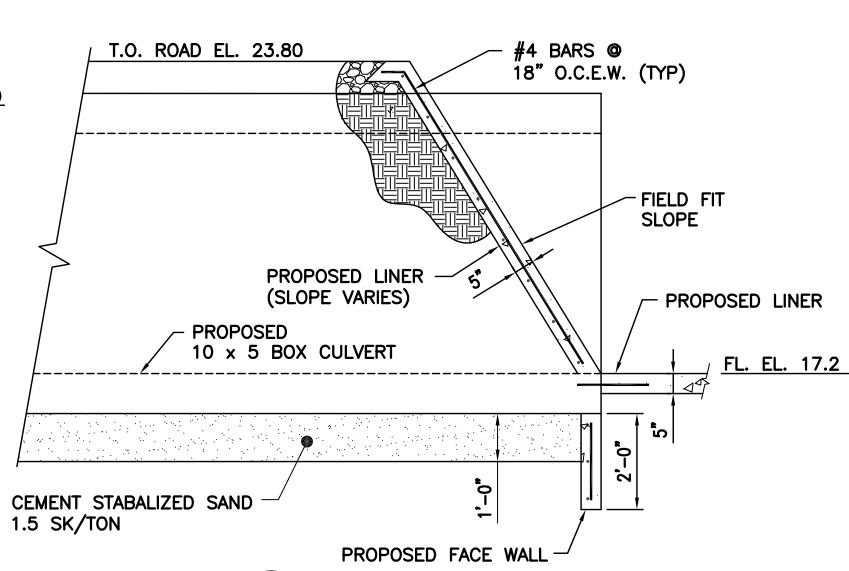

**B** SECTION  
S3 SCALE: 1/4"=1'-0"

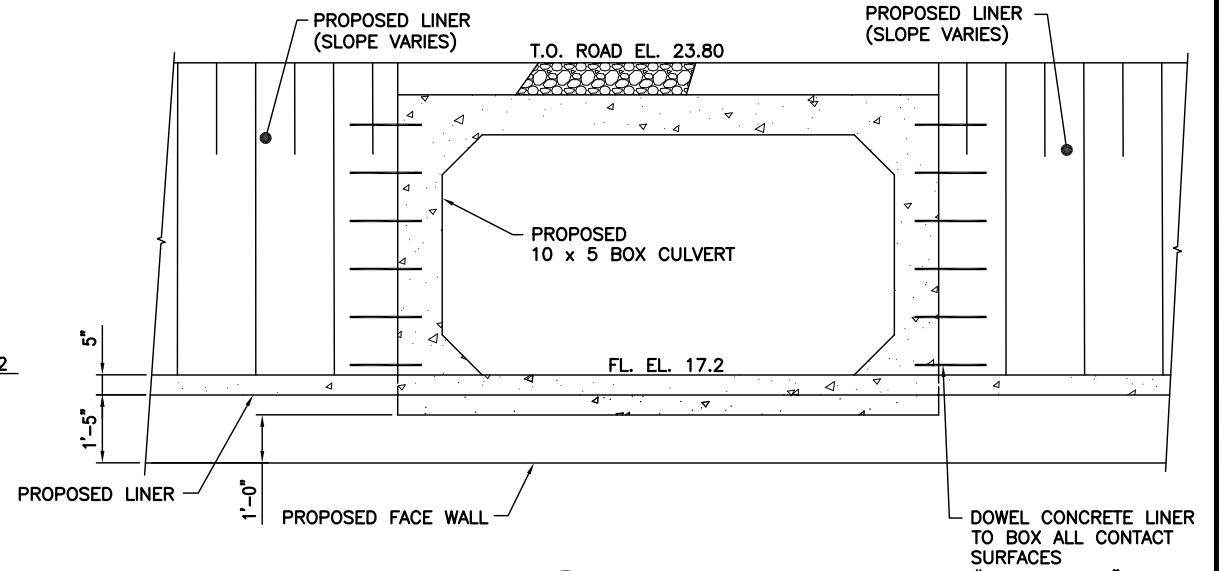

**C** SECTION  
S3 SCALE: 1/4"=1'-0"

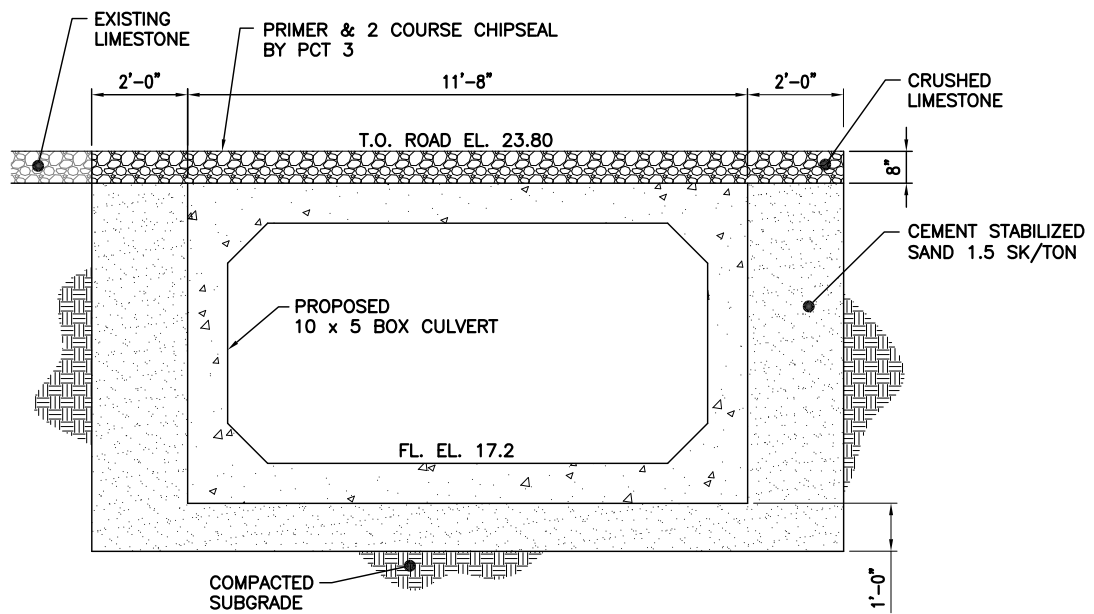

**D** SECTION  
S3 SCALE: 1/4"=1'-0"

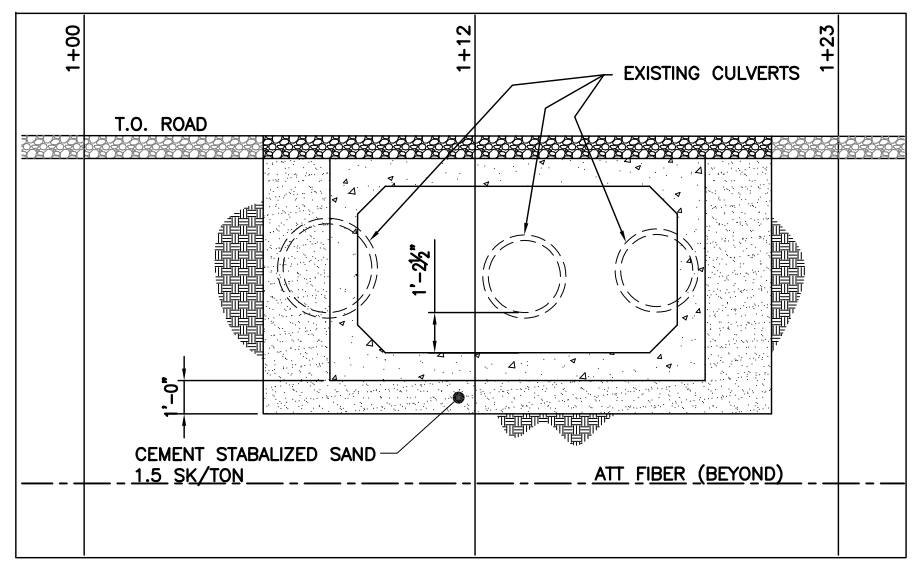

**BOX PROFILE @ CENTERLINE ROAD**  
(LOOKING WEST)  
SCALE: NTS

*M. H. Falgout*  
  
 12-10-21

- NOTES:**
1. CONCRETE BOX SHALL MEET ASTM C850 SPECIFICATION.
  2. CRUSHED LIMESTONE SHALL MEET TXDOT 247 SPECIFICATIONS.

JEFFERSON COUNTY ENGINEERING DEPARTMENT JEFFERSON COUNTY COURTHOUSE 1149 PEARL STREET, 5TH FLOOR BEAUMONT, TEXAS 77701 PHONE: (409) 835-8584 FAX: (409) 835-8718	
PROJECT: HEBERT ROAD CULVERTS REPLACEMENT	
SHEET 4 OF 5 DRW'N. BY: G.K. CHK'D. BY: M.F.	SHEET 04

**GENERAL NOTES**

1. Jefferson County (County) and DD7 will work in coordination to make notices to residence and businesses in the project area as needed regarding the road closure of Hebert Road. They will work to provide and communicate the alternate route to the north of the project site.
2. The County and or DD7 shall furnish signs and barricades as necessary to detour traffic in the area.
3. Any existing facilities outside of the project scope disturbed during construction shall be restored to their original condition.
4. Adequate drainage shall be maintained throughout the limits of the Project during all construction phases. At the conclusion of the project the project limits shall be inspected. All materials in ditches or other drainage structures resulting from the project work shall be removed and returned to pre-project condition.
5. Mud, dirt, or debris tracked onto existing streets from project work shall be removed at the end of each day or at more frequent intervals if needed. Condition of road and/or right-of-way upon completion of job shall be as good or better prior to starting work.
6. Horizontal locations of utilities shown on the plans were developed from the topographic survey of utilities provided by location services and are considered approximate. Approximate vertical locations, if provided, were developed from field locates and other information provided by the utility.

The County has performed due diligence regarding the location of utilities in the development of this project. The County and DD7 will comply with TAC Title 16, Part 1, Chapter 18 including notice to Notification Center prior to excavation and post-damage notification. All damages shall be repaired in accordance with the utility owner's standard construction practice, at no additional cost to the City.

The County and DD7 allow utility and/or pipeline companies to enter this project to accomplish such work as required for placement, relocation or protection of their services and as may be deemed necessary by the County or DD7 Engineers.

7. Utility contact information:  
 AT&T (SWBT)  
 Eddie Cook - 409-839-6950  
  
 Coastal Caverns  
 Joey - 409-549-0719
8. Water needed for dust control, compaction, moisture control or other purposes for the project will be provided by the DD7 or the County.
9. Contractor shall not park equipment in the road Right-of-Way (ROW) overnight or on weekends without reflective barricades. There shall be no stockpiling of materials in the ROW.

10. DD7 and the County shall each be responsible for providing required security to protect their own property, equipment and work in progress.
11. All OSHA regulations and State of Texas law concerning excavation, trenching and shoring shall be observed.
12. If there are any additions or changes to the project that require a change, Jefferson County and DD7 shall review and approve if deemed necessary. In addition, if different site conditions are encountered during the course of the work, the DD7 shall notify the County immediately and stop work at that location until given authorization to proceed.
13. Overhead power lines are located near or within the project site. The proper authorities shall be notified at least 72 hours before construction begins. Precautions shall be made to avoid damage to power lines, foundations, guy wires, and appurtenances. All applicable OSHA requirements shall be observed while working near the overhead power lines including restriction of height of equipment.
14. Efforts shall be made to not damage the existing beyond the limits of the construction project.
15. DD7 shall provide all labor, materials and equipment necessary for dewatering the project site during construction activities to protect excavations and prevent damage or loss within the project limits due to groundwater or stormwater flows.



JEFFERSON COUNTY ENGINEERING DEPARTMENT JEFFERSON COUNTY COURTHOUSE 1149 PEARL STREET, 5TH FLOOR BEAUMONT, TEXAS 77701 <small>PHONE: (409) 835-8584 FAX: (409) 835-8718</small>	
PROJECT: HEBERT ROAD CULVERTS REPLACEMENT	
SHEET 5 OF 5 DRW'N. BY: G.K. CHK'D. BY: M.F.	SHEET  05

<b>Hebert Road Estimate</b>					
<b>Item</b>	<b>box lengths</b>	<b>number of Boxes</b>	<b>Quantity</b>	<b>Unit Cost</b>	<b>total cost</b>
	(lf)	(each)	(ton)/(CY)		
<b>Boxes paid by the County - Delivered to the Site</b>					
Boxes	10x5	5.5	7	\$ 1,310.00	\$ 50,435.00
Boxes	shipping				\$ 2,220.00
<b>Materials installed by DD7 Paid for by County</b>					
Cement					
Stabilized					
Sand (Ton)			70	\$ 35.00	\$ 2,450.00
CS Base (Ton)			35	\$ 50.00	\$ 1,750.00
Headwalls (CY)			15	\$ 250.00	\$ 3,750.00
<b>PCT 3</b>					
Rock and Oil - estimate					\$ 4,000.00
				<b>Subtotal</b>	<b>\$ 64,605.00</b>
				<b>Contnegincy (20%)</b>	<b>\$ 12,921.00</b>
				<b>Total</b>	<b>\$ 77,526.00</b>

FEMA Funding	mitigation 0909	\$	9,048.62
	Damage 125712	\$	16,966.77
	Damage 125713	\$	17,842.00
	Damage 125714	\$	3,706.61
		<b>\$</b>	<b>47,564.00</b>

**Remaining County Portion \$ 29,962.00**

**STATE OF TEXAS**

**COUNTY OF JEFFERSON**

**§  
§  
§**

**INTERLOCAL AGREEMENT**

**WHEREAS**, Jefferson County, Texas, by and through its Commissioners' Court as authorized by Chapter 791 of the Government Code and Jefferson County Drainage District 7 (DD7), a body politic of the State of Texas, for the mutual benefit of the citizens they serve, desire to enter into a contract regarding the repair of the culvert crossing at Hebert Road and John's Gully located in Precinct #3 as shown in construction plans in Attachment A, pursuant to Chapter 791 Texas Government Code; and,

**WHEREAS**, Jefferson County has received funding from FEMA for the Hebert Road culvert crossing repairs due to damages from Hurricane Harvey in the amount of \$47,564.00; and

**WHEREAS**, Jefferson County does not have an adequate supply of labor or equipment suited for the described necessary work and all work would need to be performed by contract services; and

**WHEREAS**, through the performance of the project with construction labor and equipment being provided by DD7, the project will be performed more cost effectively and efficiently for the benefit of all parties and the citizens of Jefferson County; and

**NOW, THEREFORE, KNOW ALL BY THESE PRESENT:**

DD7 and Jefferson County hereby agree to the following as it relates to the repair and upgrade of the culvert crossing at Hebert Road and John's Gully:

1. Jefferson County to perform topographic surveying, identify utilities to the best of their ability through the 811 locate system, and develop plans and specifications for the project for use by DD7. See plans in Attachment A;
2. Jefferson County will purchase the concrete storm boxes and have them delivered to the site unless otherwise instructed by DD7;
3. Jefferson County will reimburse DD7 for rock bedding or other materials as needed for bedding under the boxes, cement stabilized sand for backfill around the boxes, concrete, rebar and form boards, for concrete liner and/or headwalls and wingwalls, limestone for placement over the boxes and other materials necessary for the project shown in the project plans and approved by Jefferson County;

ILA  
Jefferson County Texas and DD7  
Hebert Road Culvert Project

4. DD7 shall provide all labor and construction equipment for completion of the project according to plans and specifications. Activities include but are not limited to; dewatering of the ditch for the duration of the crossing repair project, removal of the following: existing road surface, existing headwall and wingwalls, existing riprap, existing culvert pipe structures under the road, excavation of the area for the placement of new box culverts, placement and backfill of the new box culverts and placement of the proposed concrete liner and/or headwalls and wingwalls as indicated by FEMA;
5. Jefferson County shall provide construction surveying/staking as necessary, or provide a Temporary Bench Mark (TBM) for use by DD7 during construction.
6. Jefferson County and DD7 shall work in conjunction to notify adjacent property owners and the Federal Jail Office on Hebert road and assist with alternate access to properties using the gate north of the structure.
7. DD7 agrees to haul and dispose of materials not subject to environmental restrictions. If environmentally restricted materials are identified, Jefferson County and DD7 will reach a mutual agreement regarding disposal of restricted materials.
8. DD7 agrees to provide appropriate records of in-kind personnel and equipment utilized for the project as needed by Jefferson County for FEMA documentation.
9. DD7 agrees to allow Jefferson County representatives to inspect the project for documentation purposes as construction progresses.
10. Jefferson County will compile documentation provided by DD7 and other paperwork to FEMA for reimbursement of project work.
11. Jefferson County agrees to pay DD7 for project materials (minus the box culverts which will be paid for directly by Jefferson County). Payment to be made in one lump sum to DD7 after Jefferson County's acceptance of the work.
12. Once DD7 has completed their scope of work, Precinct #3 will further compact the limestone over the boxes, as necessary, to attain desired compaction and furnish and install primer and a double course chip seal surface.
13. Any changes in scope of work must be mutually agreed upon in writing by both parties.
14. This agreement shall be effective on the date of its execution and may be terminated at the will of either party.
15. This agreement shall be construed according to the laws of the State of Texas.
16. Nothing in this agreement shall be construed to create the existence of an agency relationship between the parties.

ILA  
Jefferson County Texas and DD7  
Hebert Road Culvert Project

- 17. Any employee of a party performing services pursuant to this agreement shall not be deemed to be an agent or employee of the party receiving services under this agreement.
- 18. The parties further agree, pursuant to Sec. 791.015, Texas Government Code, that any dispute regarding the terms of this agreement will be submitted to an agreed upon mediator for resolution.

Executed on the 15<sup>th</sup> day of February, 2022.

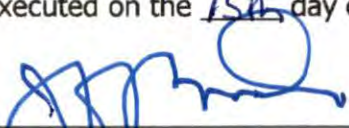
  
 \_\_\_\_\_  
 Jeff R. Branick  
 County Judge, Jefferson County

  
 \_\_\_\_\_  
 Phil Kelley  
 General Manager,  
 Drainage District #7

Attest: County Clerk

Attest:

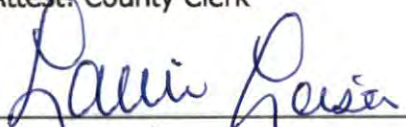
  
 \_\_\_\_\_

  
 \_\_\_\_\_



	<b>Online/Practice Solutions/Software Renewals</b>	
--	--	--

Sub Matl #	Online/Practice Solutions/Software Products	Initial Renewal Year Monthly Charges	Renewal Effective Date	Renewal Term (Months)

**Notes:**

Monthly Charges for the Initial Renewal Year are set forth above and begin on your Renewal Effective Date. The Renewal Term will continue for the number of months identified in the Renewal Term column above. If your Renewal Term is longer than 12 months, then your Monthly Charges for each year of the Renewal Term are displayed in the Pricing Attachment (#1113) to the Order Form.

When this Renewal Term expires the following will apply.

**Post-Renewal Term for Government Customers .** At the end of the Renewal Term, your Monthly Charges will increase by 7%. Thereafter, the Monthly Charges will increase 7% every 12 months unless we notify you of a different rate at least 90 days before the annual increase. Either of us may cancel the Post-Renewal Term subscription by sending at least 60 days written notice.

**Federal Government Customers Optional Minimum Term.** Federal government customers that chose a multi-year term, may exercise the option to implement those additional years pursuant to federal law.

**Automatic Renewal Term for Non-Government Subscribers Only.** If you are a non-government customers, your subscription will automatically renew at the end of the Renewal Term. Each Automatic Renewal Term will be 12 months in length and include a 7% price increase unless we notify you of a different rate at least 90 days before each Automatic Renewal Term starts. Either of us may cancel in writing at least 60 days before an Automatic Renewal Term starts.

	<b>Passwords and QuickView+</b>	
--	---------------------------------	--

Last Name	First Name, M.I.	Jdg	Clrk	Atty	Lib	Para	Other	Product(s)
Rojo	Effie						X	Westlaw

QuickView is provided as a service to you for estimating your Westlaw charges. Actual charges billed may vary from QuickView+ due to discounts you receive or other charges, such as taxes. <https://www.quickview.com>.



**ENGINEERING DEPARTMENT****AGENDA ITEM**

February 15, 2022

- a) Consider, possibly approve and authorize the County Judge to execute, receive and file an Interlocal Agreement (ILA) between Jefferson County and the Drainage District 7 (DD7) regarding the repair of the culvert crossing and Hebert Road and John's Gully, located in Precinct #3, as provided for in the construction plans and estimate in Attachment A.
- b) Execute, receive and file Pipeline Permit 01-P-22 and Road Use Agreement between Jefferson County and Kinder Morgan, for the purpose of repairing a natural gas pipeline on E. Clubb Road. This project is located in Precinct 4.

Permit Number: 01-P-22  
Precinct Number: 4  
Bond Number: SUR0066502

**APPLICATION FOR PIPE LINE PERMIT**

Date: 4/25/2022  
02/10

HONORABLE COMMISSIONERS' COURT  
JEFFERSON COUNTY  
BEAUMONT, TEXAS 77701

Ladies or Gentlemen:

Kinder Morgan Texas Pipeline LLC, (Company)

does hereby made application to use lands belonging to Jefferson County, for the purpose of constructing, maintaining or repairing a pipe line for the distribution of location of which is fully described as follow: Natural gas pipeline repair: Request to open cut E. Clubb to allow for inspection and repair of pipeline. Kinder Morgan will repair and replace road to approved condition. See attached road use agreement.

Number of drawings attached 1  
Construction will begin on or after 2/17 20 22

It is understood that all work will comply with requirements of the Pipe Line Policy adopted by Jefferson County Commissioners' Court on 2/14/22 02/15/22 and all subsequent revisions thereof to date.

Enclosed, please find the required permit fee:

1 Road crossing @\$100.00 \$ 100.00  
Miles parallel @\$150.00/mile or fraction \$ \_\_\_\_\_  
TOTAL PAID \$ 100.00

We understand that a Performance Bond will be required to protect against damage to Jefferson County's property. This will be **\$5,000.00 per crossing** and **\$50,000.00 per mile** or fraction thereof for parallel construction unless a special hazard to Jefferson County's property is judged exist. No work will begin until the County Engineer has been furnished such bonds as Jefferson County Commissioners' Court may choose to require.

Permit is issued for a period of twenty-five (25) years, at which time the permit must be renewed.

Kinder Morgan Texas Pipeline LLC  
Company Name

1001 Louisiana St. Suite 1000 Houston, TX 77002  
Address

Ryan Dahl, Attorney-in-Fact  
Company Representative Name/Title

713-396-9000  
Phone Number

**ENGINEERING ACTION FORM**

The minimum standard bond required is \$ 5000

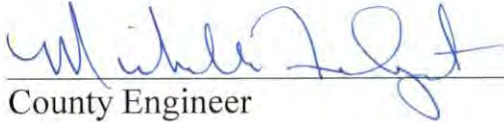
  
County Engineer

2-10-22  
Date

**COMMISSIONERS COURT ORDER**

On this date the attached application of a utility or common carrier pipeline came on for the Courts consideration, and the Court having considered the application is of the opinion that the applicant is a utility or common carrier pipeline company meeting all the requirements of County Policy for installation of a line in County roads and that the plans or details presented with said application did not appear to violate the County Regulations. It is ORDERED that said applicant shall comply with all provisions of the Utility and Common Carrier Pipe Line Policy adopted by this Court, and all subsequent revisions. The bond required shall be \$ 5000. Special conditions of construction (are/are not) attached hereto.

COMMISSIONERS COURT

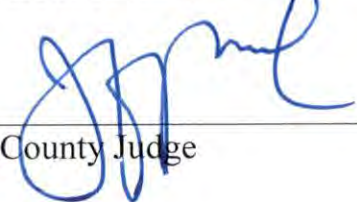
By   
County Judge

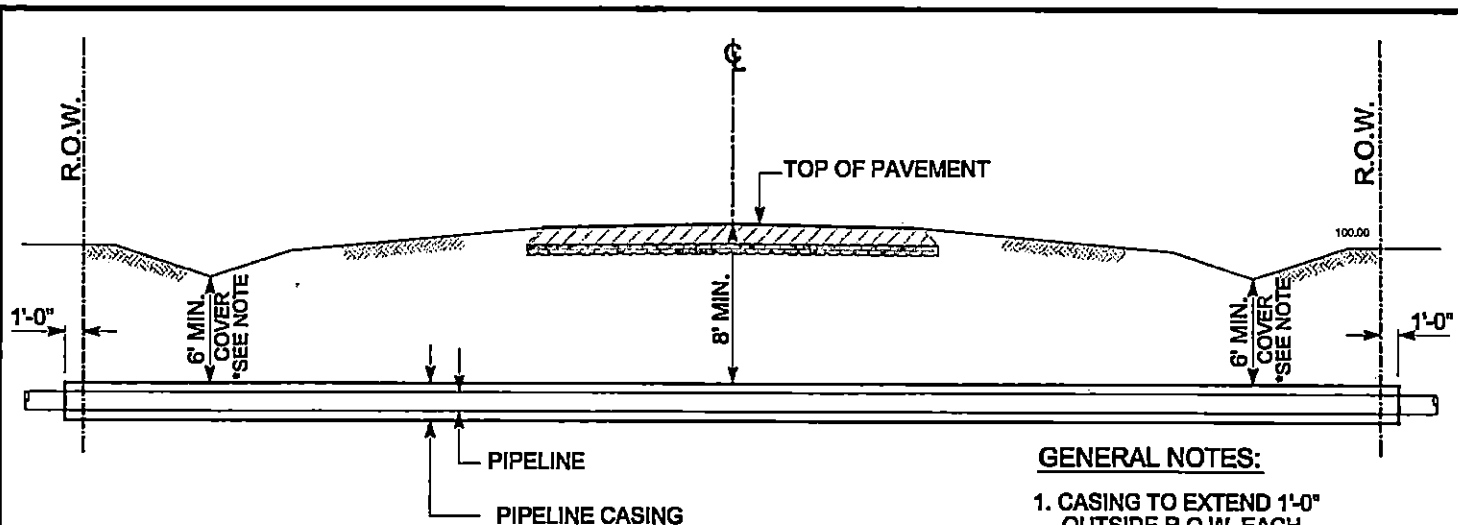

**GENERAL NOTES:**

1. CASING TO EXTEND 1'-0" OUTSIDE R.O.W. EACH SIDE OF ROAD
2. JEFFERSON COUNTY MAY EXEMPT CASING IN LIEU OF OTHER SUFFICIENT METHODS FOR PROTECTING THE PIPELINE AND PUBLIC RIGHT OF WAY
3. \* 6'-0" MINIMUM COVER AT LOWEST DITCH FLOW LINE ELEVATION

**1.) STANDARD PIPELINE CROSSING**

N.T.S

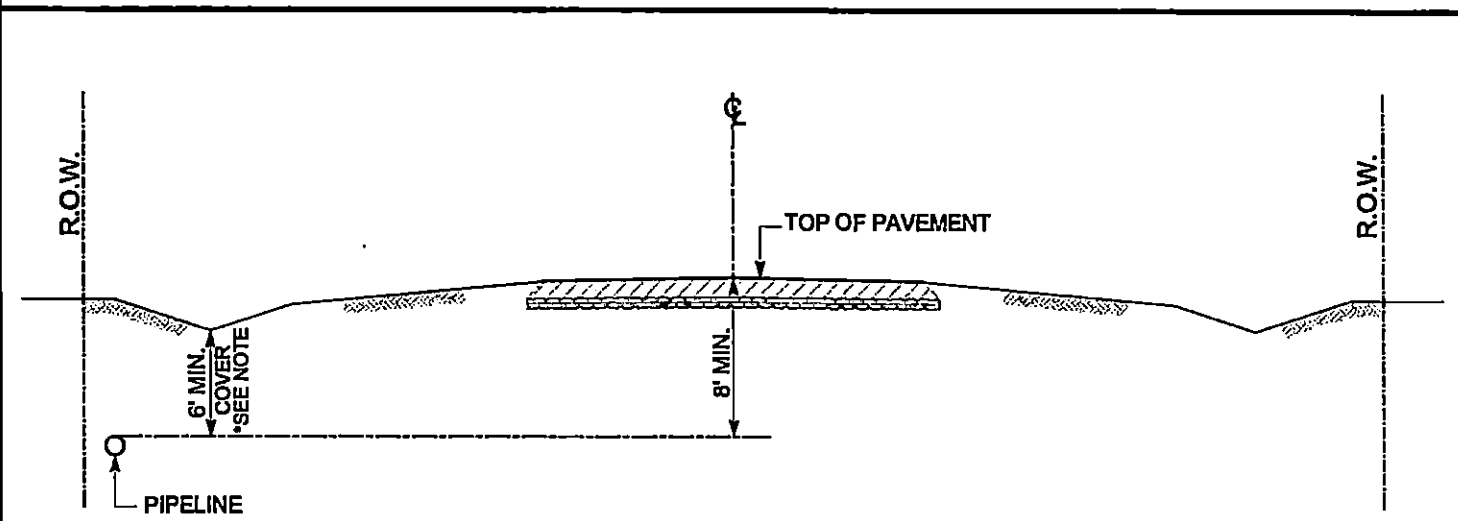

**GENERAL NOTES:**

1. \* 6'-0" MINIMUM COVER AT LOWEST DITCH FLOW LINE ELEVATION

**2.) STANDARD PARALLEL LINE**

N.T.S



**JEFFERSON COUNTY  
ENGINEERING DEPARTMENT**

**PIPELINE DETAILS (STD)**

DRAWN:	J.D.	REVISED: 01/15/2020	SHEET NO. 1 OF 1
CHECKED:	S.S.		

**LOCATION INFORMATION - DIG #2019-21A-B  
INDEX 98 - FANNETT TO GOODYEAR  
10" X 5.6 MILE PIPELINE**

PROJECT ENGINEER:	BEN ALBRECHT	CELL:	409-656-1404	OFFICE:	409-333-4141
PROJECT NUMBER:	N/A	ACTION ITEM:	2019-21A-B	KEYS:	
LOCATION:	D/S AGM #2	ATV:	NO	ACCESS BY:	TRUCK

SITE INFORMATION					
DEPTH OF COVER AT.RGW		FEATURE		CONDITION OF R.O.W.	
UP STREAM	89"	LATITUDE:	29.94201318	UPSTREAM OF ROAD	
DOWN STREAM	95"	LONGITUDE:	-94.2395558	AT PIPELINE XNG	
		DEPTH OF COVER:	91	INCHES	

**ACCESS NOTES**

DIG SITE JUST NORTH OF HWY 124

COMMENTS:

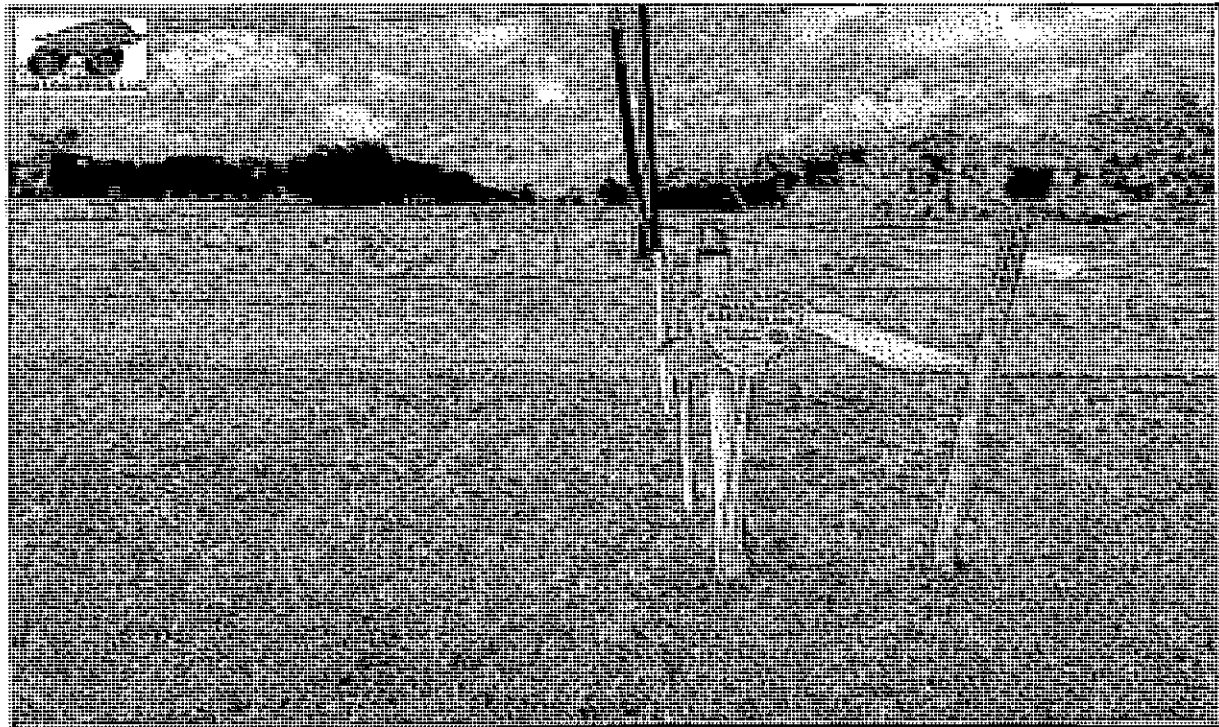
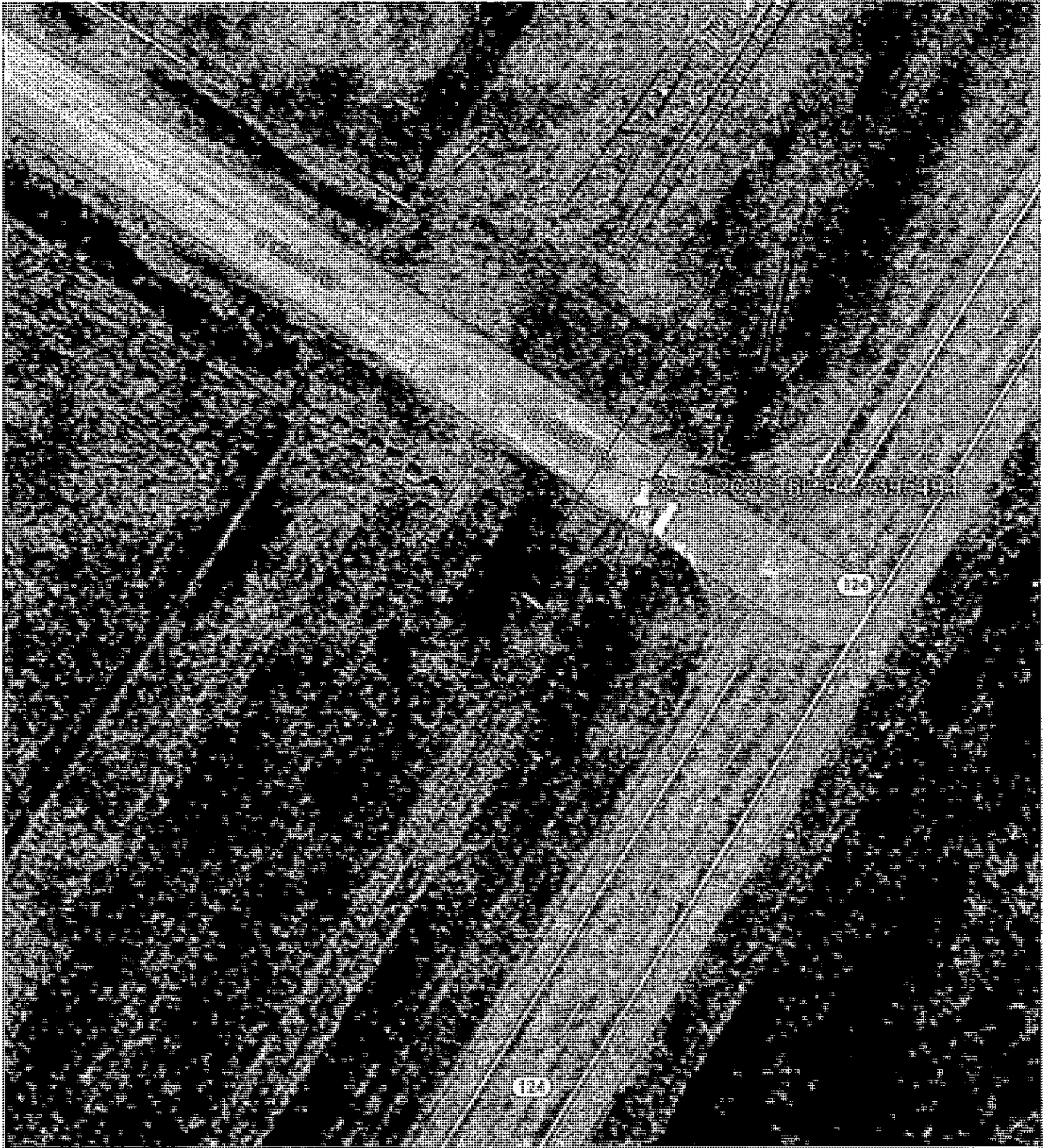
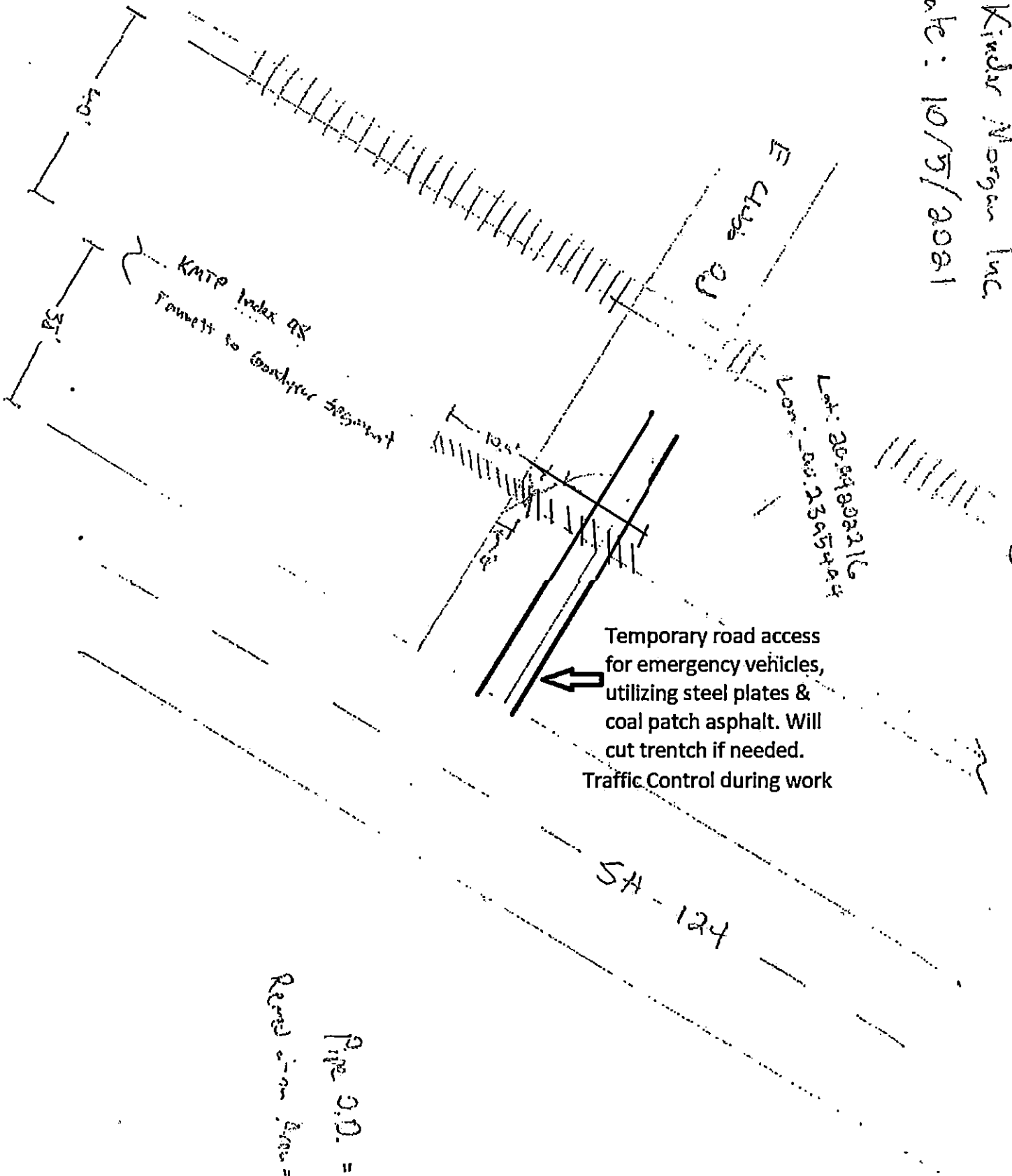

PHOTO DIRECTION: [unclear]



Prepared By: Sam Atkinson  
Kinder Morgan Inc  
Date: 10/15/2021

Dis 2016-21A



Temporary road access  
for emergency vehicles,  
utilizing steel plates &  
coal patch asphalt. Will  
cut trench if needed.  
Traffic Control during work

Revised from Area = 10.5'  
Pipe O.D. = 10.75'



**COMMITMENT OF REPAIR TO COUNTY ROAD  
AFTER REPAIR OF EXISTING PIPELINE  
ON CLUBB ROAD - JEFFERSON COUNTY TEXAS**

**KINDER MORGAN TEXAS PIPELINE – KMTP Index 98  
1755 West Cardinal Dr.  
Beaumont, Texas 77705**

October 10, 2021

**State of Texas  
County of Jefferson  
Commissioners Court**

**To Whom It May Concern:**

Please accept this commitment from Kinder Morgan Texas Pipeline, KMTP Index 98, that any damages resulting to any of the Jefferson County Roads or properties during our repair and maintenance project will be repaired back “as good or better” after our work is complete.

We are working currently with Jefferson County Engineering Group, and Precinct 4 Commissioners Office to make sure our project can be completed safely. The work will be in the Hwy 124 and Clubb Road area.

We appreciate and thank you for any advice or direction you would consider. Please contact me by phone 361-781-2362 or e-mail at [lesterkoester@gmail.com](mailto:lesterkoester@gmail.com) if have any questions or concerns.

**LESTER KOESTER**

**KINDER MORGAN- SIGNATURE GROUP**



**PERMIT PERFORMANCE BOND**

Bond No. SUR0066502

KNOW ALL MEN BY THESE PRESENTS, that we, Kinder Morgan Texas Pipeline LLC, as Principal, and Argonaut Insurance Company, licensed to do business in the State of Texas, as Surety, are held and firmly bound unto Jefferson County, 1149 Pearl Street, 5<sup>th</sup> Floor, Jefferson County Courthouse, Beaumont, TX 77701 (Obligee), in the penal sum of Five Thousand and 00/100 Dollars (\$5,000.00), lawful money of the United State of America, for the payment of which sum, well and truly to be made, the Principal and Surety do bind themselves, their heirs, executors, administrators, and successors and assigns, jointly and severally, firmly by these presents.

WHEREAS, the above bounded Principal has obtained a permit from the Obligee to work within the public right-of-way as indicated on the permit. Pipeline Permit - Dig Site Just North of HWY 124,

NOW, THEREFORE, THE CONDITION OF THIS OBLIGATION IS SUCH, that the Principal shall repair or install said facilities in the right-of-way as set forth in said permit, and complete, or cause same to be completed within the time specified on the permit for such completion; and construct same according to the plans for the facilities; and restore the right-of-way in accordance to the technical specifications used by the Obligee. If the restoration of the right-of-way endures without the need of repairs for this specified period, then this obligation shall be void; otherwise this obligation shall remain in full force and effect until the permit expires. This bond is executed by the Surety and accepted by the Obligee subject to the following express condition:

This bond shall become effective the 13<sup>th</sup> day of October, 2021, and shall remain in effect for a period of one year until the 13<sup>th</sup> day of October, 2022. The bond may be terminated by thirty (30) days written notice of cancellation by the Surety. The liability of the Surety under this bond shall in no event exceed the amount as set forth in this bond or in any additions, riders, or endorsements properly issued by the Surety as supplements as set forth in this bond or in any additions, riders, or endorsements properly issued by the Surety as supplements thereto.

Scaled with our seals and dated this 13<sup>th</sup> day of October, 2021.

Witness Bijon Williams  
Bijon Williams

Kinder Morgan Texas Pipeline LLC  
(Principal)

By Chris Gracter  
Chris Gracter, Vice President

Argonaut Insurance Company  
(Surety)

Witness Stephanie Moore  
Stephanie Moore

By Richard Covington  
Richard Covington, Attorney-In-Fact

**Argonaut Insurance Company**  
**Deliveries Only: 225 W. Washington, 24th Floor**  
**Chicago, IL 60606**  
**United States Postal Service: P.O. Box 469011, San Antonio, TX 78246**  
**POWER OF ATTORNEY**

KNOW ALL MEN BY THESE PRESENTS: That the Argonaut Insurance Company, a Corporation duly organized and existing under the laws of the State of Illinois and having its principal office in the County of Cook, Illinois does hereby nominate, constitute and appoint:

Marc W. Boots, Richard Covington, Vickie Laey, Maria D. Zuniga, Joseph R. Aulbert, Ashley Koletar, Ryan Varela

Their true and lawful agent(s) and attorney(s)-in-fact, each in their separate capacity if more than one is named above, to make, execute, seal and deliver for and on its behalf as surety, and as its act and deed any and all bonds, contracts, agreements of indemnity and other undertakings in suretyship provided, however, that the penal sum of any one such instrument executed hereunder shall not exceed the sum of:

\$95,000,000.00

This Power of Attorney is granted and is signed and sealed under and by the authority of the following Resolution adopted by the Board of Directors of Argonaut Insurance Company:

"RESOLVED, That the President, Senior Vice President, Vice President, Assistant Vice President, Secretary, Treasurer and each of them hereby is authorized to execute powers of attorney, and such authority can be executed by use of facsimile signature, which may be attested or acknowledged by any officer or attorney, of the Company, qualifying the attorney or attorneys named in the given power of attorney, to execute in behalf of, and acknowledge as the act and deed of the Argonaut Insurance Company, all bond undertakings and contracts of suretyship, and to affix the corporate seal thereto."

IN WITNESS WHEREOF, Argonaut Insurance Company has caused its official seal to be hereunto affixed and these presents to be signed by its duly authorized officer on the 1st day of June, 2021.

Argonaut Insurance Company



by: \_\_\_\_\_

Joshua C. Betz, Senior Vice President

STATE OF TEXAS  
 COUNTY OF HARRIS SS:

On this 1st day of June, 2021 A.D., before me, a Notary Public of the State of Texas, in and for the County of Harris, duly commissioned and qualified, came THE ABOVE OFFICER OF THE COMPANY, to me personally known to be the individual and officer described in, and who executed the preceding instrument, and he acknowledged the execution of same, and being by me duly sworn, deposed and said that he is the officer of the said Company aforesaid, and that the seal affixed to the preceding instrument is the Corporate Seal of said Company, and the said Corporate Seal and his signature as officer were duly affixed and subscribed to the said instrument by the authority and direction of the said corporation, and that Resolution adopted by the Board of Directors of said Company, referred to in the preceding instrument is now in force.

IN TESTIMONY WHEREOF, I have hereunto set my hand, and affixed my Official Seal at the County of Harris, the day and year first above written.



*Kathleen M. Meeks*

(Notary Public)

I, the undersigned Officer of the Argonaut Insurance Company, Illinois Corporation, do hereby certify that the original POWER OF ATTORNEY of which the foregoing is a full, true and correct copy is still in full force and effect and has not been revoked.

IN WITNESS WHEREOF, I have hereunto set my hand, and affixed the Seal of said Company, on the 13th day of October, 2021.



James Bluzard, Vice President-Surety



STATE OF TEXAS  
COUNTY OF JEFFERSON

COMMISSIONERS' COURT  
OF JEFFERSON COUNTY, TEXAS

AN ORDER REGARDING ROAD USE IN  
JEFFERSON COUNTY

1. Pursuant to Transportation Code Chapter 251.003, the Commissioners Court may make and enforce all necessary rules and orders for the construction and maintenance of public roads; and
2. Jefferson County has suffered extensive damage to its roads as a result of persons and entities hauling loads that exceed the weight limits of such roads; and
3. Jefferson County has been required to expend monies it did not budget to repair of roads damaged by those hauling excessively heavy loads; and
4. The Commissioners Court of Jefferson County, Texas finds it necessary to require that persons, firms or entities who will haul loads, which exceed the weight limits of county roads, first enter into an agreement to pay for costs of repairs occasioned by their hauling excessively heavy loads.

The Commissioners Court of Jefferson County, Texas does hereby adopt the attached Road Use Agreement to be executed by those who will haul loads which exceed the weight limit of any Jefferson County, Texas road.

Read and adopted by a vote of 4 ayes and 0 nays.

Signed this 26 day of August, 2013

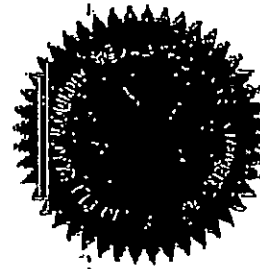

  
\_\_\_\_\_  
JUDGE JEFF R. BRANICK  
County Judge

STATE OF TEXAS  
 COUNTY OF JEFFERSON

§  
 §  
 §

**ROAD USE AGREEMENT BETWEEN JEFFERSON COUNTY  
 AND**

WHEREAS, Kinder Morgan Texas Pipeline (hereinafter "Company") intends to conduct Maintenance on KMTD Index 98 [describe operation], (hereinafter the "Project") at a site located on Clubb Rd crossing (county road name) located in Precinct No. 4; and

WHEREAS, the proposed project will require the transportation of heavy equipment or loads (loads shall include any building supplies, material or other bulk loads, including rock, gravel, cement, asphalt, timber, etc. in amounts that exceed the capacity of the road) over one or more Jefferson County, Texas road(s) identified as: [1<sup>st</sup> road name] and County [2nd road name]:

1. County Road E CLUBB
2. County Road E CLUBB; and

WHEREAS, the weight of the equipment will exceed the load bearing capacity of the identified county roads and bridges on the proposed route; and

WHEREAS, the transportation of the equipment or loads may cause substantial damage to the county roads and bridges; and

WHEREAS, Company and Jefferson County, Texas (hereinafter "County") agree that the transportation of this equipment or loads is necessary for the Project and that the County should be compensated for any damages or additional maintenance costs incurred by the County as a result of the Project; and

WHEREAS, the Company and County hereby agree and contract as follows:

1. Company may utilize County road Clubb Road and County road \_\_\_\_\_ for the transport of all necessary equipment and/or loads to the Project location on the designated county roads without weight limitations for a time period from a commencement date of 2/7, 2022 to a termination date of 3/8/22. The Project time period may be extended only by written agreement of the County after not less than five (5) days notice of a need for extension by Company.
2. Company shall pay County its actual cost, including labor, equipment use (including fuel, depreciation and overhead costs) and materials, for all repairs, replacement or maintenance incurred as a result of the transport of equipment to or from the Project location. An estimate of these costs is attached as Exhibit 1 and incorporated herein by reference.
3. Company shall provide County details of preliminary work Company will perform prior to use of road, for example: install two 1" X 8' X 25' steel plates across the bridge located north of the intersection of County [road name: E CLUBB] and County [2nd road name: E CLUBB] for additional support.

- 4. Company shall provide a surety bond in the sum of [\$ 5000.00 Estimated cost] dollars with the County Treasurer of Jefferson County, Texas upon execution of this agreement. All provisions of this agreement are contingent upon review and approval of the bond by the Jefferson County, Texas Commissioners Court. The bond shall provide for prompt payment by the surety upon demand by County for the repairs, replacement and maintenance costs incurred to return the road to substantially the same condition the road possessed prior to the commencement date of the project. However, the liability of Company for such costs is not limited to the face amount of the bond and Company agrees to pay any additional sums actually incurred to return the road to substantially the same condition of the road prior to the commencement date upon demand.
- 5. Company agrees to provide 48 hours notice to the County Commissioner or Road Superintendant for Precinct No. 4 of Jefferson County, Texas before transporting any equipment on County [road name: Club Rd and County [2nd road name: \_\_\_\_\_] that would interrupt the normal flow of traffic. Company agrees to bear the cost of any County manpower and equipment necessary to interrupt and redirect traffic during any interruption of the normal flow of traffic.

Agreed and executed this 15 day of February, 2022

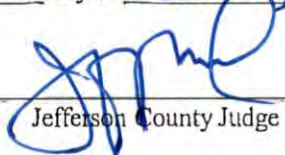
  
 \_\_\_\_\_  
 Jefferson County Judge

Approved by Jefferson County Commissioners Court on the 15th day of February, 2022

Attest:

  
 \_\_\_\_\_  
 Jefferson County Clerk



Ryan Dahl as Attorney-in-Fact  
 Authorized Agent for Kinder Morgan Texas Pipeline LLC



THE STATE OF TEXAS,

§  
§  
§

COUNTY OF ~~JEFFERSON~~ HARRIS

I, Caryn Araguz a notary public, do hereby certify that on this 8<sup>th</sup> day of February, 2022, personally appeared before me Ryan Dahl, being by me first duly sworn, declared that he is the Attorney-in-Fact of Kinder Morgan Texas Pipeline LLC and that he has been duly authorized to execute the foregoing document on behalf of the Company.

SWORN TO AND SUBSCRIBED before me on this 8<sup>th</sup> day of February, 2022.

Caryn Araguz  
Notary Public, State of Texas

Notary's Typed/Printed Name

My commission expires

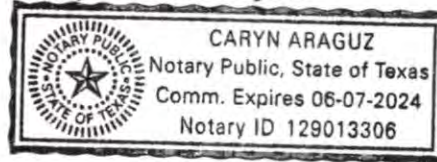

## Exhibit 1

## Estimate of Cost:

Length of [1<sup>st</sup> road name]:  
 Type of road surface/material:  
 Number of culverts/bridges:  
 Any other special features:  
 Length of [2<sup>nd</sup> road name]:  
 Type of road surface/material:  
 Number of culverts/bridges:  
 Any other special features:

Anticipated cost of Repair:  
 Repeat for each Road: [1<sup>st</sup> road name]

Labor: (Rate includes salary/benefits/overtime, where applicable)

Foreman \$ 32 per hour x \_\_\_\_\_ hours = \$ \_\_\_\_\_

Equipment Operator \$ 30 per hour x \_\_\_\_\_ hours = \$ \_\_\_\_\_

Other \$ 30 per hour x \_\_\_\_\_ hours = \$ \_\_\_\_\_

Equipment: (Rate includes fuel, depreciation and overhead costs (insurance).

Truck \$ 95 per hour x \_\_\_\_\_ hours = \$ \_\_\_\_\_

Grader \$ 95 per hour x \_\_\_\_\_ hours = \$ \_\_\_\_\_

Other \$ 95 per hour x \_\_\_\_\_ hours = \$ \_\_\_\_\_

Material: (Rate includes cost to acquire and transport to location)

Base mtl \$ 100 Per Ton + \$ \_\_\_\_\_ per hour x \_\_\_\_\_ hours = \$ \_\_\_\_\_

Asphalt \$ 100 Per Ton + \$ \_\_\_\_\_ per hour x \_\_\_\_\_ hours = \$ \_\_\_\_\_

Other at \$ 100 Per Ton + \$ \_\_\_\_\_ per hour x \_\_\_\_\_ hours = \$ \_\_\_\_\_

Total for [1<sup>st</sup> road name] \$ E. CLUBB ROAD

TRAFFIC CONTROL PLAN

10930 E CLUBB RD  
BEAUMONT, TEXAS

SHEET INDEX

TRAFFIC CONTROL PLAN .....TC1



VICINITY MAP  
NOT TO SCALE



SUBMITTED BY: *L. Stella S. Valley*  
LESTELLA S. VALLEY, P.E.  
SUN STAR SERVICES, LLC

FEBRUARY 7, 2022  
DATE



- NOTES:  
 1. ALL DEVICES SHALL BE SET IN ACCORDANCE WITH THE LATEST EDITION OF THE TMLTCD.  
 2. REFER TO TXDOT STANDARD BC-14 FOR ADDITIONAL NOTES REGARDING TRAFFIC CONTROL REQUIREMENTS.  
 3. REFER TO TXDOT STANDARD TCP (1-1) - 1B FOR ADDITIONAL NOTES.  
 4. SANDBAGS SHALL BE USED AS BALLAST ON ALL BARRICADES AND SIGNS.  
 5. COORDINATION WITH OTHERS SHOULD TAKE PLACE PRIOR OF CONSTRUCTION ACTIVITY AND THE INSTALLATION OF TEMPORARY TRAFFIC CONTROL DEVICES.  
 6. BARRICADE COMPANY TO CONFIRM SPEED PRIOR TO SETTING BARRICADES.  
 7. MESSAGE BOARD TO BE SET IN ADVANCE TO NOTIFY DRIVERS DATE OF CLOSURE PER GOVERNING AGENCY.

**STREET TRAFFIC CONTROL & WORK HOURS**

STREET	WORK HOURS	DURATION	PLANNED IMPROVEMENT
E CLUBB RD	24 HOURS	2 WEEKS	PIPELINE WORK

- LEGEND**
- MESSAGE BOARD
  - SIGN STAND
  - TY 3 BARRICADE
  - WORK AREA



MESSAGE BOARD PANEL

E CLUBB RD	DATE
TO BE	TIME
CLOSED	

PANEL 1                      PANEL 2

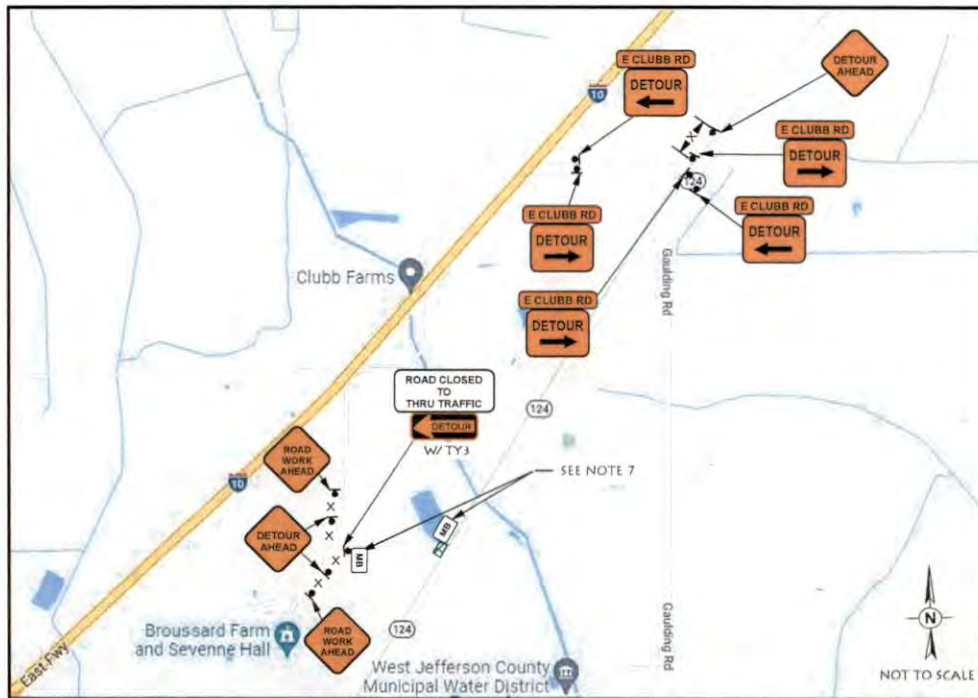

**ADDITIONAL DETOUR SIGNAGE MAP**

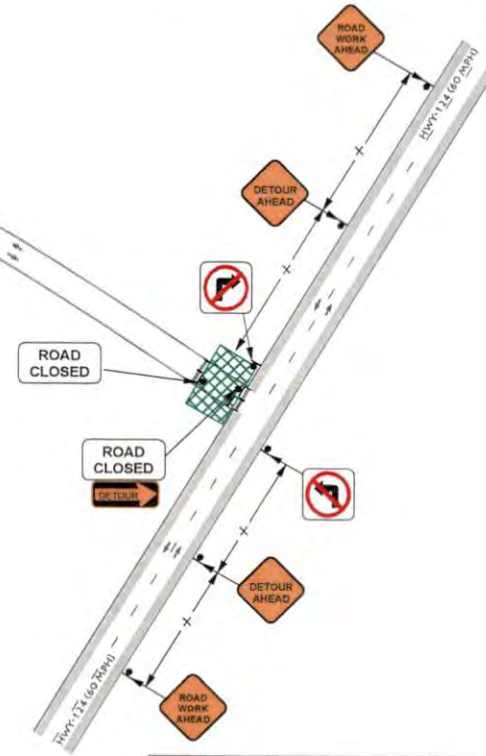

Typical Transition Lengths and Suggested Maximum Spacing of Devices

Posted Speed *	Formula	Minimum Desirable Taper Lengths **			Suggested Maximum Space of Channelizing Devices		Minimum Sign Spacing "X" Distance	Suggested Longitudinal Buffer Space "B"
		10' Offset	11' Offset	12' Offset	On a Taper	On a Tangent		
30	$L = \frac{WS}{60}$	150'	165'	180'	30'	60'	120'	90'
35		205'	225'	245'	35'	70'	160'	120'
40		265'	295'	320'	40'	80'	240'	155'
45		450'	495'	540'	45'	90'	320'	195'
50	$L = WS$	500'	550'	600'	50'	100'	400'	240'
55		550'	605'	660'	55'	110'	500'	295'
60		600'	660'	720'	60'	120'	600'	350'
65		650'	715'	780'	65'	130'	700'	410'
70		700'	770'	840'	70'	140'	800'	475'
75		750'	825'	900'	75'	150'	900'	540'

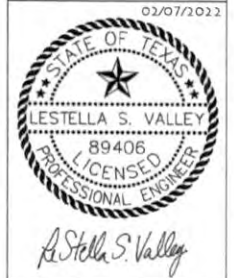

DRAWN BY: LSV      PROJECT NO: 22050

10930 E CLUBB RD  
 BEAUMONT, TEXAS

TRAFFIC CONTROL PLAN  
 PHASE 1

PROJECT NAME:  
 SHEET NAME:  
 CITY JOB NO.:

SHEET NO.:

**Special, February 15, 2022**

There being no further business to come before the Court at this time,  
same is now here adjourned on this date, February 15, 2022