



**JEFFERSON COUNTY, TEXAS  
PURCHASING DEPARTMENT**

1149 Pearl Street – First Floor  
Beaumont, Texas 77701  
409-835-8593 phone

**ADDENDUM TO IFB**

IFB Number: 21-004/JW

IFB Title: Phase VI: First Time Sanitary Sewer Improvements Project for Jefferson County  
(Community Development Block Grant) (TxCDBG No. 7218240)

IFB Due: **11:00 am CT, Wednesday, March 24, 2021**

Addendum No.: 2

Issued (Date): March 11, 2021

**TO BIDDER:** This Addendum is an integral part of the IFB package under consideration by you as a Bidder in connection with the subject matter herein identified. Jefferson County deems all sealed proposals to have been proffered in recognition and consideration of the entire IFB package – **including all addenda.** For purposes of clarification, **receipt of this present Addendum by a Bidder should be evidenced by returning it (signed) as part of the Bidder’s sealed proposal.** If the Proposal has already been received by the Jefferson County Purchasing Department, Bidder should return this addendum in a separate sealed envelope, clearly marked with the IFB Title, IFB Number, and Opening Date and Time, as stated above.

---

**Reason for Issuance of this addendum:**

- **Revisions to Bid Form (ATTACHED)**
- **Revisions to Construction Plan Sheet # 9 (ATTACHED)**
- **Deadline for Project Question Submission: 5:00 pm, CT, Tuesday, March 16, 2021**

Please submit questions to Jamey West via email at [jwest@co.jefferson.tx.us](mailto:jwest@co.jefferson.tx.us)

---

**The information included herein is hereby incorporated into the documents of this present Bid matter and supersedes any conflicting documents or portion thereof previously issued.**

---

Receipt of this Addendum is hereby acknowledged by the undersigned Bidder:

ATTEST:

\_\_\_\_\_  
Witness

\_\_\_\_\_  
Witness

\_\_\_\_\_  
Authorized Signature (Bidder)

\_\_\_\_\_  
Title of Person Signing Above

\_\_\_\_\_  
Typed Name of Business or Individual

Approved by \_\_\_\_ Date: \_\_\_\_\_

\_\_\_\_\_  
Address

## BID SUMMARY

**Owner:** Jefferson County, Texas  
 1149 Pearl Street, 1<sup>st</sup> floor  
 Beaumont, Texas 77701

**Engineer:** LJA Engineering, Inc.  
 2615 Calder Avenue, Suite 500  
 Beaumont, Texas 77702  
 409-833-3363

**Project:** Jefferson County, Texas  
 Phase VI: First-Time Sanitary Sewer Improvements Project  
 TDA – TxCDBG No. 7218240

Receipt is hereby acknowledged of the following addenda to the Plans and Contract Documents.

Addendum No. 1 Dated _____	Received _____
Addendum No. 2 Dated _____	Received _____
Addendum No. 3 Dated _____	Received _____
Addendum No. 4 Dated _____	Received _____

### BASE BID ITEMS

ITEM NO.	ESTIMATED QUANTITIES	DESCRIPTION	UNIT PRICE	TOTAL AMOUNT BID
1	1 L.S.	<p><b>Mobilization</b> costs including transportation, moving on site, payment bond, performance bond, insurance, submittals, NOT TO EXCEED 3% of project total, all in accordance with the Plans and Specifications, for</p> <p>_____</p> <p>_____ dollars and</p> <p>_____ cents</p> <p>per L.S.</p>	\$ _____	\$ _____

ITEM NO.	ESTIMATED QUANTITIES	DESCRIPTION	UNIT PRICE	TOTAL AMOUNT BID
2	9 EA	<p>Furnish and install <b>Sanitary Sewer Grinder Pump Station</b>, to the limits shown in the plans, complete in place, including but not limited to, meeting/coordination with homeowner, SCH 40 PVC gravity piping tie-in(s), cleanouts, fiberglass tank &amp; cover, submersible grinder pump, control panel, 30A breaker disconnect, electrical conduit &amp; conductors, and floats, to the limits shown in the plans, complete in place, including but not limited to, the connections to proposed and existing equipment, fittings, hardware, excavation, backfill, surface restoration, seeding, utility coordination, testing and all necessary appurtenances, all in strict accordance with the Plans and Specifications for</p> <p>_____</p> <p>_____dollars and</p> <p>_____cents</p> <p>per EA.</p>	\$ _____	\$ _____
3	5 EA	<p>Construct <b>Near Side Sanitary Sewer Service Connection</b> with 1-1/2" HDPE SDR 11 pipe, to the limits shown in the plans, complete in place, all depths, including but not limited to, tapping saddle, valves, fittings, plastic valve box, tracer wire, boring, backfill, seeding, surface restoration, testing, utility coordination, and all appurtenances, all in strict accordance with the Plans and Specifications for</p> <p>_____</p> <p>_____dollars and</p> <p>_____cents</p> <p>per EA.</p>	\$ _____	\$ _____

ITEM NO.	ESTIMATED QUANTITIES	DESCRIPTION	UNIT PRICE	TOTAL AMOUNT BID
4	4 EA	<p>Construct <b>Far Side Sanitary Sewer Service Connection</b> with 1-1/2" HDPE SDR 11 pipe, to the limits shown in the plans, complete in place, all depths, including but not limited to, tapping saddle, valves, fittings, plastic valve box, tracer wire, boring, backfill, seeding, surface restoration, testing, utility coordination, and all appurtenances, all in strict accordance with the Plans and Specifications for</p> <p>_____</p> <p>_____ dollars and</p> <p>_____ cents</p> <p>per EA.</p>	\$ _____	\$ _____
5	12 EA	<p><b>Abandon Existing On-site Sanitary Sewer Facility</b>, complete in place, all depths, including but not limited to, disposal of contents in the tank in accordance with all local, state, &amp; federal laws, demolition of existing structures, backfill, surface restoration, seeding, and all appurtenances, all in strict accordance with the Plans and Specifications for</p> <p>_____</p> <p>_____ Dollars and</p> <p>_____ Cents per EA</p>	\$ _____	\$ _____

ITEM NO.	ESTIMATED QUANTITIES	DESCRIPTION	UNIT PRICE	TOTAL AMOUNT BID
6	1 LS	<p>Furnish and install an <b>On-site Sanitary Sewer Facility at 9529 Gilbert Road</b>, to the limits shown in the plans, complete in place, including but not limited to, meeting/coordination with homeowner, 2-year operation &amp; maintenance contract, filing of permit through Jefferson County and TCEQ, SCH 40 PVC gravity piping tie-in(s), cleanouts, piping, and electrical equipment, conduit, &amp; conductors, to the limits shown in the plans, complete in place, including but not limited to, the connections to proposed &amp; existing equipment, fittings, hardware, excavation, backfill, surface restoration, seeding, utility coordination, testing and all necessary appurtenances, all in strict accordance with the Plans and Specifications for</p> <p>_____</p> <p>_____dollars and</p> <p>_____cents</p> <p>per LS.</p>	\$ _____	\$ _____

ITEM NO.	ESTIMATED QUANTITIES	DESCRIPTION	UNIT PRICE	TOTAL AMOUNT BID
7	1 LS	<p>Furnish and install an <b>On-site Sanitary Sewer Facility at 14252 Dubois Road</b>, to the limits shown in the plans, complete in place, including but not limited to, meeting/coordination with homeowner, 2-year operation &amp; maintenance contract, filing of permit through Jefferson County and TCEQ, SCH 40 PVC gravity piping tie-in(s), cleanouts, piping, and electrical equipment, conduit, &amp; conductors, to the limits shown in the plans, complete in place, including but not limited to, the connections to proposed &amp; existing equipment, fittings, hardware, excavation, backfill, surface restoration, seeding, utility coordination, testing and all necessary appurtenances, all in strict accordance with the Plans and Specifications for</p> <p>_____</p> <p>_____dollars and</p> <p>_____cents</p> <p>per LS.</p>	\$ _____	\$ _____

ITEM NO.	ESTIMATED QUANTITIES	DESCRIPTION	UNIT PRICE	TOTAL AMOUNT BID
8	1 LS	<p>Furnish and install an <b>On-site Sanitary Sewer Facility at 16539 Sandell Drive</b>, to the limits shown in the plans, complete in place, including but not limited to, meeting/coordination with homeowner, 2-year operation &amp; maintenance contract, filing of permit through Jefferson County and TCEQ, SCH 40 PVC gravity piping tie-in(s), cleanouts, piping, and electrical equipment, conduit, &amp; conductors, to the limits shown in the plans, complete in place, including but not limited to, the connections to proposed &amp; existing equipment, fittings, hardware, excavation, backfill, surface restoration, seeding, utility coordination, testing and all necessary appurtenances, all in strict accordance with the plans and specifications for</p> <p>_____</p> <p>_____dollars and</p> <p>_____cents</p> <p>per LS.</p>	\$ _____	\$ _____
9	1 LS	<p>Provide Trench Safety Plan, sealed by a Professional Engineer licensed in Texas, complete in place, all in strict accordance with the plans and specifications for</p> <p>_____</p> <p>_____Dollars and</p> <p>_____Cents per LS.</p>	\$ _____	\$ _____

ITEM NO.	ESTIMATED QUANTITIES	DESCRIPTION	UNIT PRICE	TOTAL AMOUNT BID
10	1,200 LF	Trench Safety System in accordance with specification item No. 950 for all excavations in excess of 5 feet deep, complete in place, including design, supervision, maintenance, and all necessary appurtenances, all in strict accordance with the plans and specifications for _____ _____ _____ Dollars and _____ Cents per LF	\$ _____	\$ _____
11	500 SF	Special shoring as required for Trench Safety in accordance with specification item No. 950, complete in place, including design, supervision, maintenance, and all necessary appurtenances, all in strict accordance with the Plans and Specifications for _____ _____ _____ Dollars and _____ Cents per SF	\$ _____	\$ _____

**TOTAL BASE BID:**

\_\_\_\_\_

\_\_\_\_\_

\_\_\_\_\_ (\$ \_\_\_\_\_ .)



**ALTERNATE BID ITEMS**

ITEM NO.	ESTIMATED QUANTITIES	DESCRIPTION	UNIT PRICE	TOTAL AMOUNT BID
A1	1,200 L.F.	<p>Construct <b>2" PVC SDR 21 Sanitary Sewer Force Main</b> by Open Cut installed in trench, by Boring, or by Directional Drilling, complete in place, all depths, including fittings, valves, polywrap, boring, directional drilling insertion pits, steel casing, necessary clearing, embedment, backfill, thrust blocking, surface restoration, seeding, testing, and all appurtenances, all in strict accordance with the Plans and Specifications for</p> <p>_____</p> <p>_____ dollars and</p> <p>_____ cents</p> <p>per LF.</p>	\$ _____	\$ _____

**TOTAL ALTERNATE BID:**

\_\_\_\_\_

\_\_\_\_\_

\_\_\_\_\_ (\$ \_\_\_\_\_ .)

**TOTAL BID PRICE**

TOTAL BASE BID ITEMS: \$ \_\_\_\_\_.

TOTAL ALTERNATE BID ITEMS: \$ \_\_\_\_\_.

TOTAL AMOUNT BID: \$ \_\_\_\_\_.

*(Base Bid plus Alternate Bid Items)*

Amounts are to be shown in both words and figures. In case of discrepancy the amounts shown in words will govern. The above unit prices shall include all labor, materials, bailing, shoring, removal, overhead, profit, insurance, etc., to cover the finished work of the several kinds called for.

If the contract is to be awarded, it will be awarded to the Best Bid, the lowest Bidder or the Bidder whose evaluation by OWNER or whose Bid indicates to the OWNER that the award will be in the best interest of the Project.

Bidder understands that the Owner reserves the rights to reject any and all bids and to waive any informalities in the bidding. Bidder acknowledges that quantities are not guaranteed, and final payment will be based on actual quantities determined as provided in the Contract Documents and Specifications, if applicable.

Bidder agrees that the work will be completed and ready for final payment within **100 working days**. Bidder accepts the provision of the agreement as to liquidated damages in the event of failure to complete the Work within the times specified in the agreement.

The undersigned Bidder proposes and agrees, if this Bid is accepted, to enter into an agreement with Owner to perform all Work as specified or indicated in the Bidding Documents for the prices and within the times indicated in the Bid and in accordance with the other terms and conditions for the Bidding Documents.

In submitting this bid, Bidder represents that Bidder has visited the Site and become familiar with and is satisfied as to the general, local and site conditions that may affect cost, progress and performance of the work.

The bidder agrees that this bid shall be good and may not be withdrawn for a period of 90 calendar days after the scheduled bid opening for bids.

**Bidder:** \_\_\_\_\_

**Address:** \_\_\_\_\_

\_\_\_\_\_

\_\_\_\_\_

**Telephone:** \_\_\_\_\_

**Signed:** \_\_\_\_\_

**By:** \_\_\_\_\_

**Title:** \_\_\_\_\_

**Date:** \_\_\_\_\_

**Attest:** \_\_\_\_\_

**Bidder: Complete & Return this Form with Offer.**



SCALE: 1" = 60'

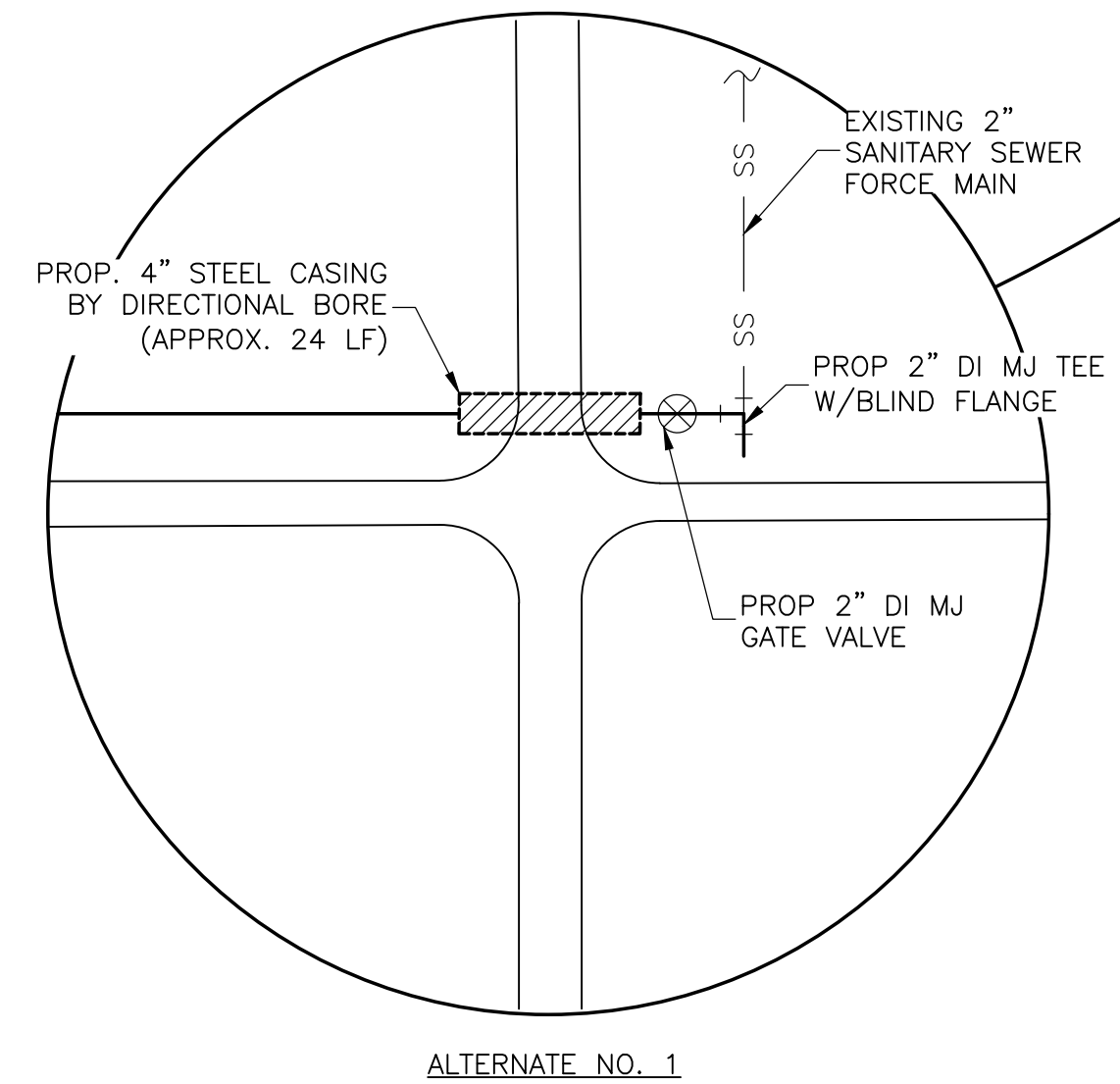

**LEGEND**

● PP	POWER POLE	○ CO	MANHOLE
● LP	LIGHT POLE	—	CLEAN OUT
◇ FH	FIRE HYDRANT	—	PROPOSED SANITARY SEWER LINE
→ GA	GUY ANCHOR	—	PROPOSED WATER LINE
▲ TS	TRAFFIC SIGN	— SS —	SANITARY SEWER LINE
L.S.	LANDSCAPING	— W —	WATER LINE
TVJB	TV BOX	— X —	CHAIN LINK FENCE
WM	WATER METER	— // —	WOOD FENCE
ESB	ELECTRICAL SERVICE BOX	— TEL —	UNDERGROUND TELEPHONE LINE
TJB	TELEPHONE JUNCTION BOX	— FO —	UNDERGROUND FIBER OPTICS
RCP	REINFORCED CONCRETE PIPE	— GAS —	UNDERGROUND GAS LINE
CMP	CORRUGATED METAL PIPE	— UGE —	UNDERGROUND ELECTRIC LINE
[Hatched Box]	BUILDING	— OHE —	OVERHEAD ELECTRIC LINE
[Stippled Box]	CONCRETE	—	PROPERTY LINE
1234	ADDRESSES	[Cloud Shape]	BUSHES
		[Flower Shape]	TREES

NOTE:  
THE CONTRACTOR SHALL COORDINATE WITH THE ENGINEER AND OWNER ON THE EXACT LOCATION OF THE PROPOSED LPSS SYSTEM. THE LPSS SYSTEM LOCATION WILL VARY FOR EACH HOUSE

O:\PROJECTS LJA B000 - BXXX\B857-JEFFERSON COUNTY\1003 - GLO CDBG PHASE VI - GRINDER PUMP STATION\CAD\B857-1003-09-15 PLAN SHEETS ADDENDUM 2.DWG

Date : 3/11/2021 File Name : B857/1003 File Drawer No. : B857/1003/CAD		<table border="1"> <thead> <tr> <th>No.</th> <th>Revisions</th> <th>By</th> <th>Checked</th> <th>Date</th> </tr> </thead> <tbody> <tr> <td>▲</td> <td>ADDENDUM NO. 1</td> <td>JAD</td> <td>JAD</td> <td>3/3/21</td> </tr> <tr> <td>▲</td> <td>ADDENDUM NO. 2</td> <td>JAD</td> <td>JAD</td> <td>3/11/21</td> </tr> </tbody> </table>	No.	Revisions	By	Checked	Date	▲	ADDENDUM NO. 1	JAD	JAD	3/3/21	▲	ADDENDUM NO. 2	JAD	JAD	3/11/21
No.	Revisions	By	Checked	Date													
▲	ADDENDUM NO. 1	JAD	JAD	3/3/21													
▲	ADDENDUM NO. 2	JAD	JAD	3/11/21													

**LJA Engineering, Inc.**

2615 Calder Avenue, Suite 500  
Beaumont, Texas 77702

Phone 409.833.3363  
Fax 409.833.0317  
FRN - F-1386

JEFFERSON COUNTY, TEXAS PHASE IV  
FIRST TIME SANITARY SEWER PROJECT  
CDBG PROJECT NO. 7218240

SANITARY SEWER PLAN SHEET  
(ALTERNATE BID NO. 1)

Action	Name	Date
Design	TJB	01/21
Drawn	RH	01/21
Checked	MM	01/21
Approved	TJB	01/21
Scale	AS SHOWN	
Sheet	9	Of 19